



**PARTS
CATALOGUE
CATALOGO
DE REPUESTOS**

E60H'06 (69D5)



1E69D-200S1

(2E69D-200S1)

A1

E60H
PARTS CATALOGUE
©2005 by Yamaha Motor Co., Ltd.
1st edition, October 2005
All rights reserved.
Any reprinting or unauthorized use
without the written permission of
Yamaha Motor Co., Ltd.
is expressly prohibited.
Printed in Japan.

E60H
CATALOGO DE REPUESTOS
©2005 por Yamaha Motor Co., Ltd.
1ª edición, octubre 2005
Todos los derechos reservados.
Toda reproducción o uso no autorizado
sin el consentimiento escrito de
Yamaha Motor Co., Ltd.
quedan expresamente prohibidos
Impreso en Japón.

FOREWORD

This Parts Catalogue is related to the parts for the model(s) on the cover page. When you are ordering replacement parts, please refer to this Parts Catalogue and quote both part numbers and part names correctly.

1. Modifications or additions which have been made after the issue of the Parts Catalogue will be announced in the Parts News.
It is advisable that you make the necessary corrections to the Parts Catalogue according to the Parts News.

2. Abbreviations

The following abbreviations are used in this Parts Catalogue.

“UR” Use specified parts number.

“UN” Use as many as needed.

“AP” Alternate Parts

“LM” Locally Made (Parts need to be ordered locally)

“F#” Frame No. (Applicable machine No.)

“O/S” Over Size

3. The number of components for assembly

- Parts, which are to be supplied in an assembly, are listed with a dot (.) in front of the part name as shown below.
- The numeral appearing to the right of each component part indicates the quantity of parts for each assembly unit.

PART NO.	DESCRIPTION	Q'TY	REMARKS
2F5-83310-60	FRONT FLASHER LIGHT ASSY	2	
115-83311-60	.BULB (6V-18W)	1	

4. Applicable colours of graphics are represented in the “REMARKS” as shown below.

PART NO.	DESCRIPTION	Q'TY	REMARKS
2N4-24110-00-X5	FUEL TANK COMP.	2	MXR
3J1-24240-10	.GRAPHIC, FUEL TANK	1	FOR MXR

5. Note that the illustrations for reference in finding parts numbers are not to be used for assembling. When assembling, please use the applicable service manual.

6. The asterisk (*) before a reference number indicates modified items after the first edition.

7. Applicable Serial No.

Engine Serial No.

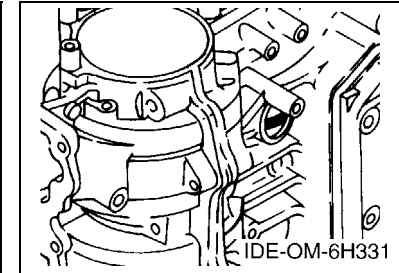
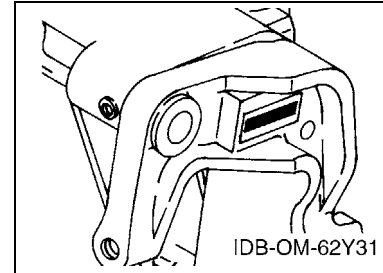

8. Applicable Engine Starting Serial No.

Model	Serial No.	Model	Serial No.
E60H	6K5K-1005972		

9. Applicable Colour Code

Abbreviation	Colour Name	Colour Code
DBNM2	DARK BLUISH GRAY METALLIC 2	004D

10. Quantity Column Information

Column No.	Name Of Q'ty Column	Applicable Model
1	MHD	E60HMHD
2	WHD	E60HWHD
3	WD	E60HWD

PROLOGO

Este catálogo de repuestos corresponde a las piezas para el o los modelos que figuran en la página de portada. Al formular el pedido de repuestos, se ruega citar este catálogo y especificar correctamente el número y el nombre de las piezas.

- Las modificaciones y agregados que se hayan realizado después de la edición de este Catálogo de Repuestos, serán anunciados en las Informaciones de Recambios. Es recomendable que se hagan las correcciones necesarias en el Catálogo de Repuestos de acuerdo con las Informaciones de Recambios.

2. Abreviaciones

En este. Catálogo de Repuestos se emplean las siguientes abreviaciones.

- “UR” Usar el número de partes especificado
- “UN” Usar la cantidad necesaria
- “AP” Piezas sustitutivas
- “LM” Fabricación local (Hay que pedir los repuestos en las cercanías)
- “F#” N° de bastidor (N° aplicable a la máquina)
- “O/S” Sobredimensionado

3. La cantidad de componentes para el montaje

- Los componentes, suministrados como conjunto, se describen con un punto (.) que precede al nombre del parte como se indica a continuación.
- La numeración que aparece a la derecha de cada descripción indica la cantidad de partes por cada unidad de conjunto.

CODIGO N°	DESCRIPCION	CANT.	OBSERVACIONES
2F5-83310-60	ENSAMBLAJE DE LA LUZ	2	
115-83311-60	.BOMBILLA (6V-18W)	1	

4. Los colores de los componentes se indican como sigue en la columna de “OBSERVACIONES”.

CODIGO N°	DESCRIPCION	CANT.	OBSERVACIONES
2N4-24110-00-X5	COMP. DEL TANQUE	2	MXR
3J1-24240-10	.GRAFICO, DEL TANQUE	1	PARA MXR

- Debe tenerse en cuenta que las ilustraciones sirven como guía para la búsqueda de los números de partes y no deben usarse para el montaje. Durante el montaje, se recomienda usar el manual de taller correspondiente.

- EL asterisco (*) antes del número de referencia indica los elementos modificados después de la primera edición.

7. Números de serie

N° de Serie del motor

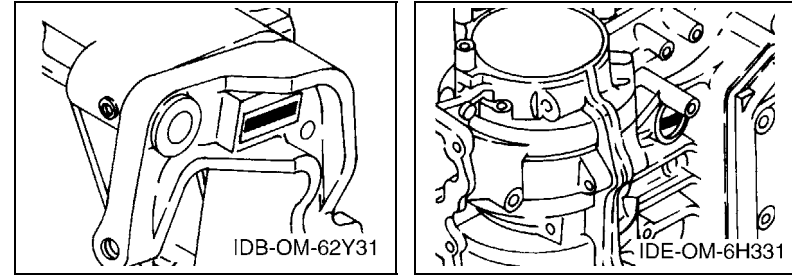

8. Números de serie del motor

Modelo	N° de serie	Modelo	N° de serie
E60H	6K5K-1005972		

9. Códigos de color aplicables

Abreviatura	Nombre de color	Código de color
DBNM2	DARK BLUISH GRAY METALLIC 2	004D

10. Información para la columna de cantidades

Columna N°	Nombre de la columna de cantidades	Modelo aplicable
1	MHD	E60HMHD
2	WHD	E60HWHD
3	WD	E60HWD

CONTENTS

SHEET1/2

TOP COWLING	A4
CYLINDER & CRANKCASE	A5
CRANKSHAFT & PISTON	A7
INTAKE	B2
CARBURETOR	B3
FUEL	B5
STARTER	B7
GENERATOR	C3
ELECTRICAL 1	C4
ELECTRICAL 2	C6
ELECTRICAL 3	C7
ELECTRICAL 4	D1
ELECTRICAL 5	D2
STARTING MOTOR	D3
BOTTOM COWLING	D4
STEERING	D6
CONTROL	E2
BRACKET 1	E4
BRACKET 2	E7
BRACKET 3	F1
BRACKET 4	F4
UPPER CASING	F6

INDEX

NUMERICAL INDEX	G1
-----------------------	----

SHEET2/2

LOWER CASING & DRIVE 1	A4*
LOWER CASING & DRIVE 2	B1*
LOWER CASING & DRIVE 3	B4*
FUEL TANK	B6*
STEERING GUIDE	B7*
REMOTE CONTROL BOX	C1*
REMOTE CONTROL ASSY	C2*
METER	C5*
REPAIR KIT 1	C6*
REPAIR KIT 2	D1*

INDEX

NUMERICAL INDEX	G1*
-----------------------	-----

CONTENIDO

PAGINA1/2

SOPORTE SUPERIOR	A4
CYLINDRO & CARTER	A5
CIGUENAL & PISTON	A7
ADMISION	B2
CARBURADOR	B3
COMBUSTIBLE	B5
ARRANQUE	B7
GENERADOR	C3
EQUIPO ELECTRICO 1	C4
EQUIPO ELECTRICO 2	C6
EQUIPO ELECTRICO 3	C7
EQUIPO ELECTRICO 4	D1
EQUIPO ELECTRICO 5	D2
MOTOR DE ARRANQUE	D3
CUBIERTA INFERIOR	D4
DIRECCION	D6
CONTROL	E2
SOPORTE 1	E4
SOPORTE 2	E7
SOPORTE 3	F1
SOPORTE 4	F4
FUNDA SUPERIOR	F6

INDICE

INDICE NUMERICO	G1
-----------------------	----

PAGINA2/2

IMPULSOR E INFERIOR 1	A4*
IMPULSOR E INFERIOR 2	B1*
IMPULSOR E INFERIOR 3	B4*
DEPOSITO DE COMBUSTIBLE	B6*
DIRECCIONGUIAR	B7*
CONTROL REMOTO COMPLETO	C1*
CONTROL REMOTO COMPL	C2*
MEDIDOR	C5*
ESTUCHE REPARATION 1	C6*
ESTUCHE REPARATION 2	D1*

INDICE

INDICE NUMERICO	G1*
-----------------------	-----

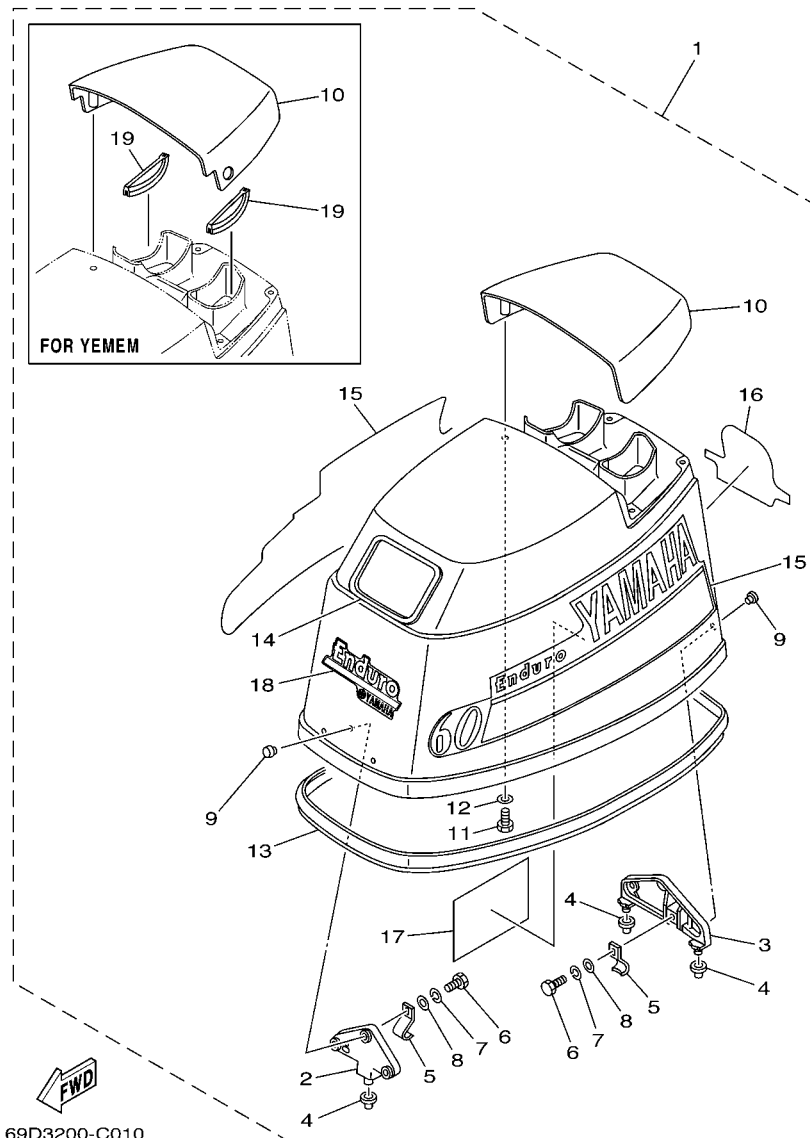

69D3200-C010

FIG. 1 TOP COWLING

SOPORTE SUPERIOR

REF. NO.	PART NO. CODIGO Nº	DESCRIPTION DESCRIPCION	MHD	WHD	WD	REMARKS OBSERVACIONES
1	69D-42610-H0-4D	TOP COWLING ASSY SOPORTE SUPERIOR COMPL.	1	1	1	
	69D-42610-00-4D	TOP COWLING ASSY SOPORTE SUPERIOR COMPL.		1		FOR YEM FOR YEM
2	6H3-42647-00-94	.HOLDER, CLAMP BAND .MORDAZA DE ABRAZADERA	1	1	1	
3	6H3-42649-00-94	.HOLDER, CLAMP BAND .MORDAZA DE ABRAZADERA	1	1	1	
4	663-42662-00	.DAMPER .AMORTIGUADOR	3	3	3	
5	6H3-42652-00	.HOOK .GANCHO	2	2	2	
6	97095-06016	.BOLT .PERNO	2	2	2	
7	92995-06100	.WASHER, SPRING .ARANDELA	2	2	2	
8	92995-06600	.WASHER .ARANDELA	2	2	2	
9	90266-06009	.RIVET .REMACHE	6	6	6	
10	6H3-42613-01-4D	.MOLDING, AIR DUCT .MOLDURA CONDUCTO AIRE	1	1	1	
	69D-42620-00-4D	.AIR DUCT ASSY .DUCTO DE AIRE COMPL.		1		FOR YEM FOR YEM
11	97095-06016	.BOLT .PERNO	4	4	4	
12	92995-06600	.WASHER .ARANDELA	4	4	4	
13	6H3-42615-00	.SEAL .SELLO	1	1	1	
14	6K5-15761-00	.SEAL, RUBBER 1 .SELLO DE GOMA 1	1	1	1	
15	6K5-W0070-H0	.GRAPHIC SET JUEGO DE EMBLEMA	1	1	1	
16	6K5-42678-H0	.GRAPHIC, REAR .CALCAMONIA TRASERA	1	1	1	
17	677-13437-0B	.MARK, CAUTION .MARKER	1	1	1	
18	69D-42677-H0	.GRAPHIC, FRONT .CALCAMONIA FRONTAL	1	1	1	
19	69D-42616-00	.GROMMET, TOP COWLING .TAPON DE SOPORTE SUPERIOR COM	2			FOR YEM FOR YEM

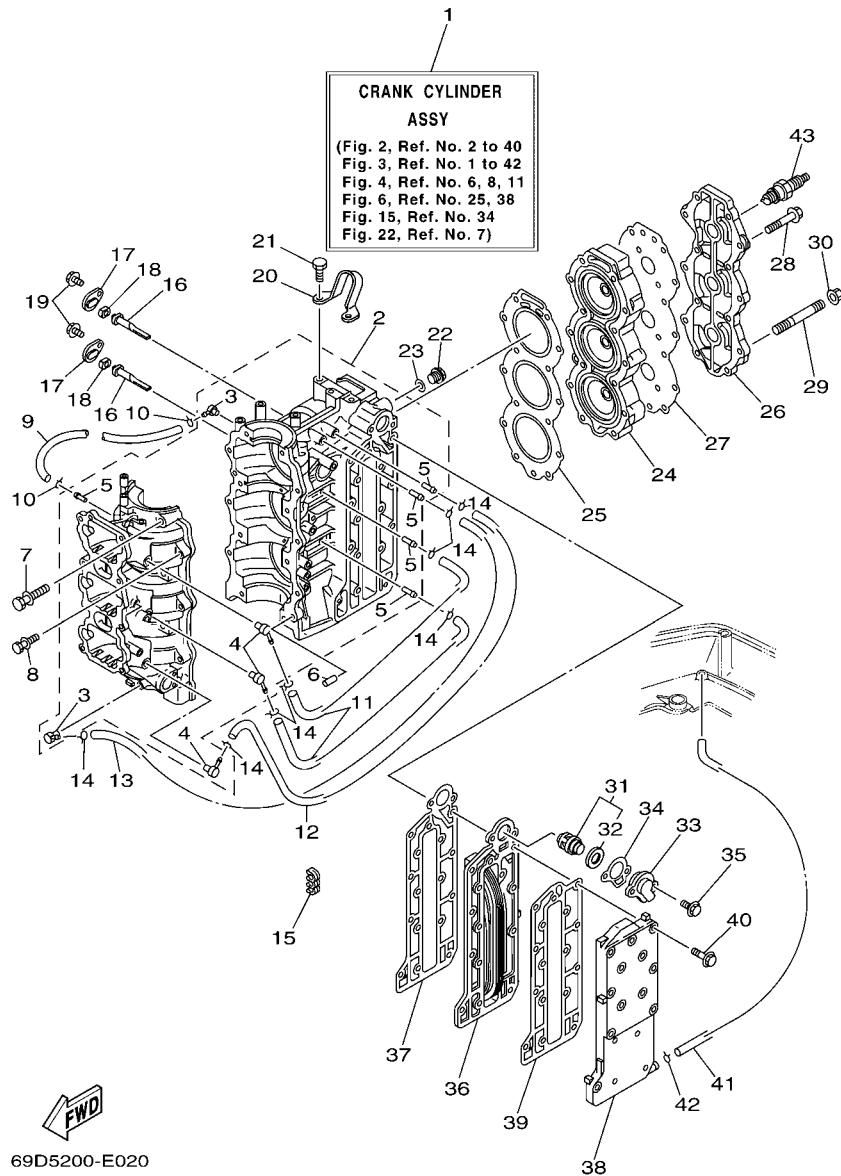

69D5200-E020

FIG. 2 CYLINDER & CRANKCASE CYLINDRO & CARTER

REF. NO.	PART NO. CODIGO Nº	DESCRIPTION DESCRIPCION	MHD	WHD	WD	REMARKS OBSERVACIONES
1	69D-W0090-01-1S	CRANK CYLINDER ASSY BLOQUE MOTOR COMPLETO	1	1	1	
2	69D-15100-00-1S	CRANKCASE ASSY CARTER COMPLETO	1	1	1	
3	688-11370-01	.CHECK VALVE ASSY .VALVULA DE CONTROL COMPL.	2	2	2	
4	650-11370-01	.CHECK VALVE ASSY .VALVULA DE CONTROL COMPL.	3	3	3	
5	624-14485-00	.PIPE, JOINT .TUBO DE UNION	5	5	5	
6	93608-12063	PIN, DOWEL PASADOR DE CLAVIJA	2	2	2	
7	90119-10005	BOLT, WITH WASHER TORNILLO CON ARANDELA	8	8	8	
8	90119-08M64	BOLT, WITH WASHER TORNILLO CON ARANDELA	6	6	6	
9	90445-07M44	HOSE (L250) TUBO (L250)	1	1	1	
10	90467-06016	CLIP PRESILLA	2	2	2	
11	90445-07M02	HOSE (L167) TUBO (L167)	2	2	2	
12	90445-07M45	HOSE (L340) TUBO (L340)	1	1	1	
13	90445-07M82	HOSE (L440) TUBO (L440)	1	1	1	
14	90467-06016	CLIP PRESILLA	8	8	8	
15	90464-07M05	CLAMP BRIDA	1	1	1	
16	6H3-11325-01	ANODE ANODO	2	2	2	
17	6H3-11327-00-1S	COVER, ANODE CUBIERTA DE ANODO	2	2	2	
18	6H3-11328-00	GROMMET, ANODE TAPON	2	2	2	
19	90119-06023	BOLT, WITH WASHER TORNILLO CON ARANDELA	2	2	2	
20	6K5-11119-01	HANGER, ENGINE SOPORTE DEL MOTOR	1	1	1	
21	90101-08002	BOLT TORNILLO	2	2	2	
22	90340-14M00	PLUG, STRAIGHT SCREW TORNILLO, DE DRENAJE	1	1	1	
23	90430-14115	GASKET JUNTA	1	1	1	
24	6H3-11111-01-1S	HEAD, CYLINDER 1 CULATA CILINDRO 1	1	1	1	
25	6H3-11181-A1	GASKET, CYLINDER HEAD 1 JUNTA, DE CULATA 1	1	1	1	
26	6H3-11191-00-1S	COVER, CYLINDER HEAD 1 TAPA CULATA DE CILINDRO 1	1	1	1	
27	6H3-11193-A1	GASKET, HEAD COVER 1 EMPAQUE	1	1	1	

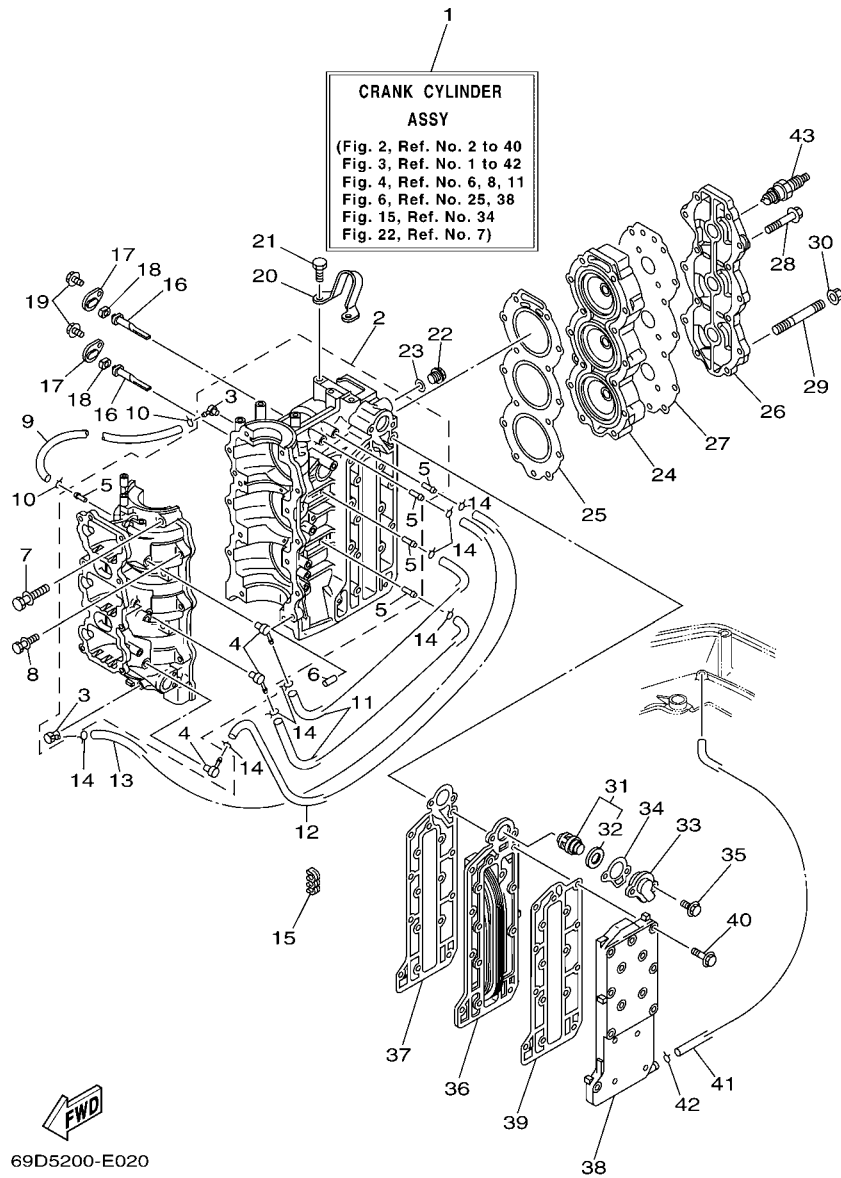

69D5200-E020

FIG. 2 CYLINDER & CRANKCASE CYLINDRO & CARTER

REF. NO.	PART NO. CODIGO Nº	DESCRIPTION DESCRIPCION	MHD	WHD	WD	REMARKS OBSERVACIONES
28	90119-08MA5	BOLT, WITH WASHER TORNILLO CON ARANDELA	13	13	13	
29	90116-08M69	BOLT, STUD ESPARRAGO	1	1	1	
30	90179-08M34	NUT TUERCA	1	1	1	
31	6H3-12411-11	THERMOSTAT TERMOSTAT	1	1	1	
32	688-12412-00	.SEAL, THERMOSTAT .SELLO TERMOSTATO	1	1	1	
33	6H3-12413-00-1S	COVER, THERMOSTAT CUBIERTA TERMOSTATO	1	1	1	
34	6H3-12414-A1	GASKET, COVER EMPAQUE	1	1	1	
35	90119-06MA3	BOLT, WITH WASHER TORNILLO CON ARANDELA	2	2	2	
36	6H3-41111-01-1S	INNER COVER, EXHAUST CUBIERTA INTERIOR DE ESCAPE	1	1	1	
37	6H3-41112-A0	GASKET, EXHAUST INNER COVER EMPAQUE	1	1	1	
38	6H3-41113-02-1S	OUTER COVER, EXHAUST CUBOERTA EXTERIOR DE ESCAPE	1	1	1	
39	6H3-41114-A0	GASKET, EXHAUST OUTER COVER EMPAQUE	1	1	1	
40	90119-06MA5	BOLT, WITH WASHER TORNILLO CON ARANDELA	16	16	16	
	90119-06MA5	BOLT, WITH WASHER TORNILLO CON ARANDELA	14			FOR YEM FOR YEM
41	663-24312-01	PIPE 2 TUBO 2	1	1	1	
42	90467-08004	CLIP PRESILLA	1	1	1	
43	94702-00160	PLUG, SPARK (NGK B8HS-10) BUJIA (NGK B8HS-10)	3	3	3	
	94702-00247	PLUG, SPARK (NGK BR8HS-10) BUJIA (NGK BR8HS-10)	3	3	3	FOR CAR,CHN,TWN FOR CAR,CHN,TWN

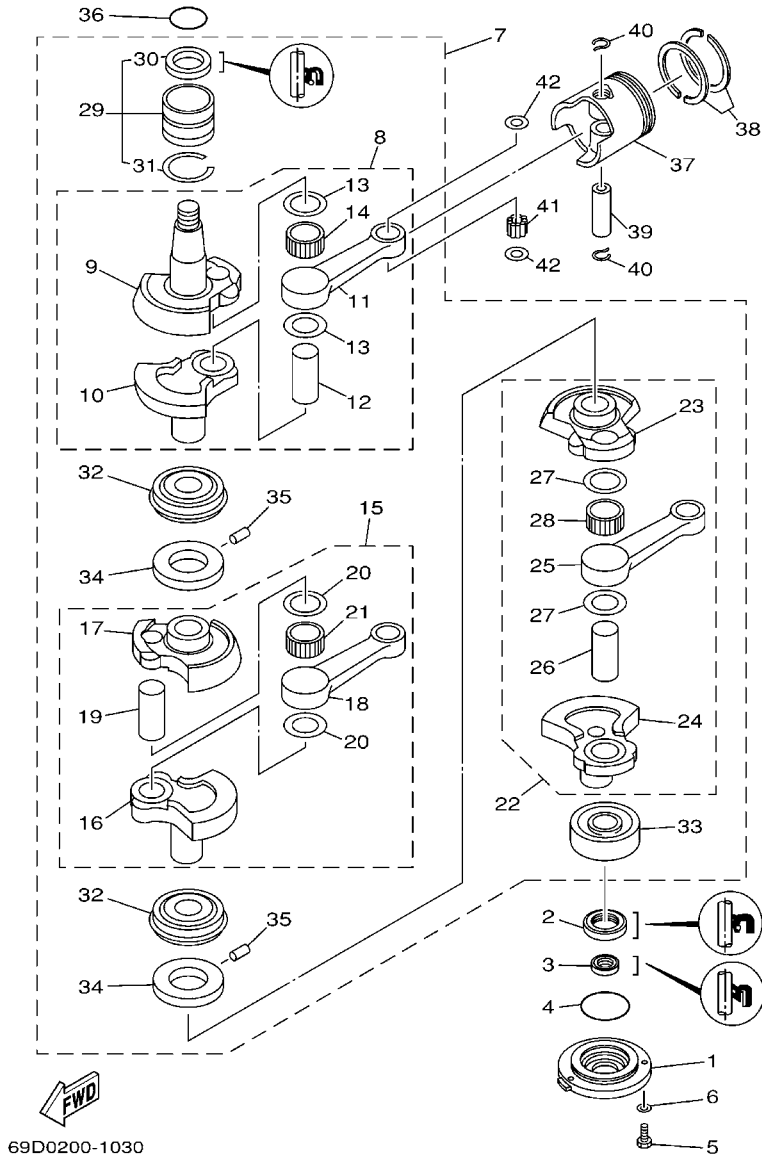
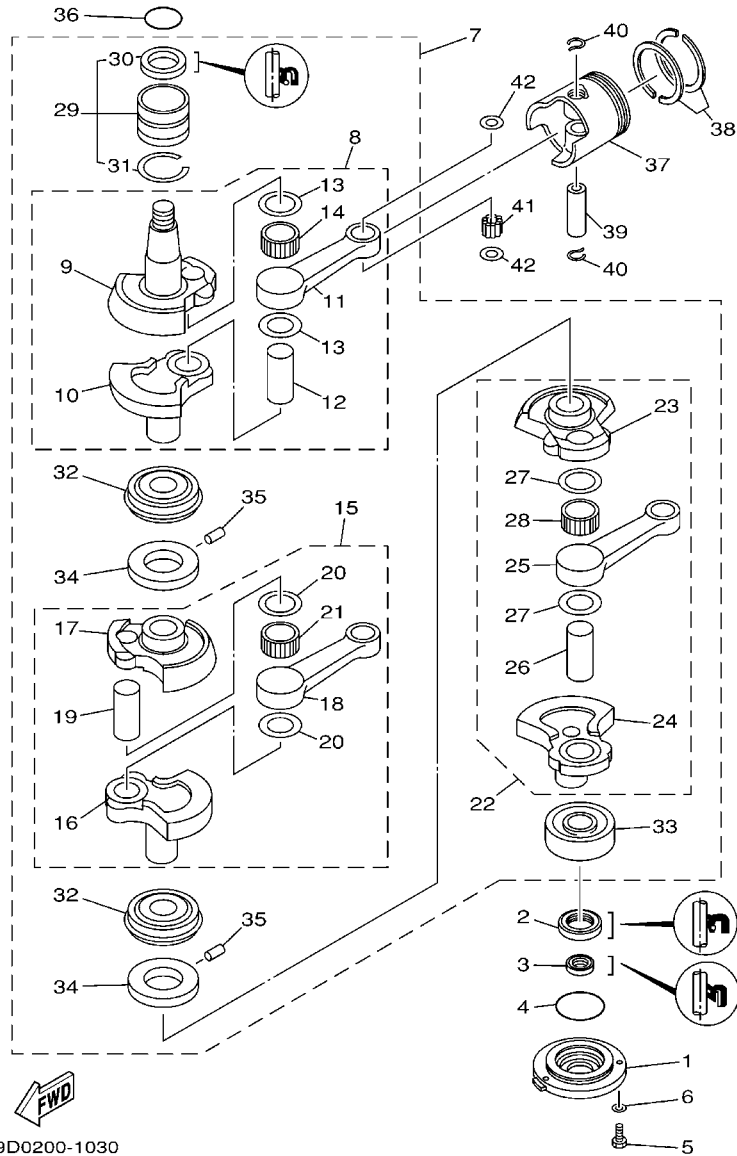

FIG. 3 CRANKSHAFT & PISTON

CIGUENAL & PISTON

REF. NO.	PART NO. CODIGO N°	DESCRIPTION DESCRIPCION	MHD	WHD	WD	REMARKS OBSERVACIONES
1	6H3-15359-00-94	HOUSING, OIL SEAL CAJA DE SELLO DE ACEITE	1	1	1	
2	93102-30009	OIL SEAL SELLO ACEITE	1	1	1	
3	93106-18001	OIL SEAL SELLO ACEITE	1	1	1	
4	93210-65M50	O-RING ANILLO O	1	1	1	
5	97095-06020	BOLT PERNO	3	3	3	
6	92995-06600	WASHER ARANDELA	3	3	3	
7	69D-W1140-01	CRANKSHAFT ASSY CIGUENAL COMPLETO	1	1	1	
8	6K5-11401-00	..CRANK SUB ASSY 1 ..MANIVELA SEMI-ARMADA 1	1	1	1	
9	6K5-11412-00	..CRANK 1 ..MANIVELA 1	1	1	1	
10	6K5-11422-00	..CRANK 2 ..MANIVELA 2	1	1	1	
11	6K5-11651-00	..ROD, CONNECTING ..BIELA	1	1	1	
12	6K5-11681-00	..PIN, CRANK 1 ..PASADOR MANIVELA 1	1	1	1	
13	90209-27011	..WASHER ..ARANDELA DE SEPARACION	2	2	2	
14	93310-527W1	..BEARING ..COJINETE DE RODILLOS	1	1	1	
15	6K5-11402-00	..CRANK SUB ASSY 2 ..MANIVELA SEMI-ARMADA 2	1	1	1	
16	6K5-11422-00	..CRANK 2 ..MANIVELA 2	1	1	1	
17	6H3-11432-00	..CRANK 3 ..MANIVELA 3	1	1	1	
18	6K5-11651-00	..ROD, CONNECTING ..BIELA	1	1	1	
19	6K5-11681-00	..PIN, CRANK 1 ..PASADOR MANIVELA 1	1	1	1	
20	90209-27011	..WASHER ..ARANDELA DE SEPARACION	2	2	2	
21	93310-527W1	..BEARING ..COJINETE DE RODILLOS	1	1	1	
22	6K5-11403-00	..CRANK SUB ASSY 3 ..CONJUNTO SUBMANIVELA 3	1	1	1	
23	6H3-11432-00	..CRANK 3 ..MANIVELA 3	1	1	1	
24	6K5-11442-00	..CRANK 4 ..MANIVELA 4	1	1	1	
25	6K5-11651-00	..ROD, CONNECTING ..BIELA	1	1	1	
26	6K5-11681-00	..PIN, CRANK 1 ..PASADOR MANIVELA 1	1	1	1	
27	90209-27011	..WASHER ..ARANDELA DE SEPARACION	2	2	2	



69D0200-1030

FIG. 3 CRANKSHAFT & PISTON

CIGUENAL & PISTON

REF. NO.	PART NO. CODIGO Nº	DESCRIPTION DESCRIPCION	MHD	WHD	WD	REMARKS OBSERVACIONES
28	93310-527W1	..BEARING ..COJINETE DE RODILLOS	1	1	1	
29	93311-636U6	..BEARING ..COJINETE DE RODILLOS	1	1	1	
30	93102-36M24	..OIL SEAL ..SELLO ACEITE	1	1	1	
31	93440-49M04	..CIRCLIP ..SEGURO	1	1	1	
32	93332-000UE	..BEARING ..COJINETE	2	2	2	
33	93306-306V1	..BEARING ..COJINETE	1	1	1	
34	6H3-11515-00	..SEAL, LABYRINTH 1 ..SELLO LABERINTO 1	2	2	2	
35	90254-03002	..PIN, SPRING ..PASADOR DE TIPO A RESORTE	2	2	2	
36	93210-46M16	O-RING ANILLO O	1	1	1	
37	6K5-11631-03-95	PISTON (STD) PISTON (NORMA)	3	3	3	
	6K5-11635-03	PISTON (0.25MM O/S) PISTON (0.25MM O/S)	3	3	3	AP AP
	6K5-11636-03	PISTON (0.50MM O/S) PISTON (0.50MM O/S)	3	3	3	AP AP
38	6K5-11601-02	PISTON RING SET (STD) JUEGO DE AROS (NORMA)	3	3	3	
	6K5-11601-12	PISTON RING SET (0.25MM O/S) JUEGO DE AROS (0.25MM O/S)	3	3	3	AP AP
	6K5-11601-22	PISTON RING SET (0.50MM O/S) JUEGO DE AROS (0.50MM O/S)	3	3	3	AP AP
39	6H3-11633-00	PIN, PISTON PASADOR, PISTON	3	3	3	
40	688-11634-10	CLIP, PISTON PIN PRESILLA, BULON DE PISTON	6	6	6	
41	93603-18M09	PIN, DOWEL PASADOR DE CLAVIJA	84	84	84	
42	90201-20417	WASHER, PLATE ARANDELA PLANA	6	6	6	

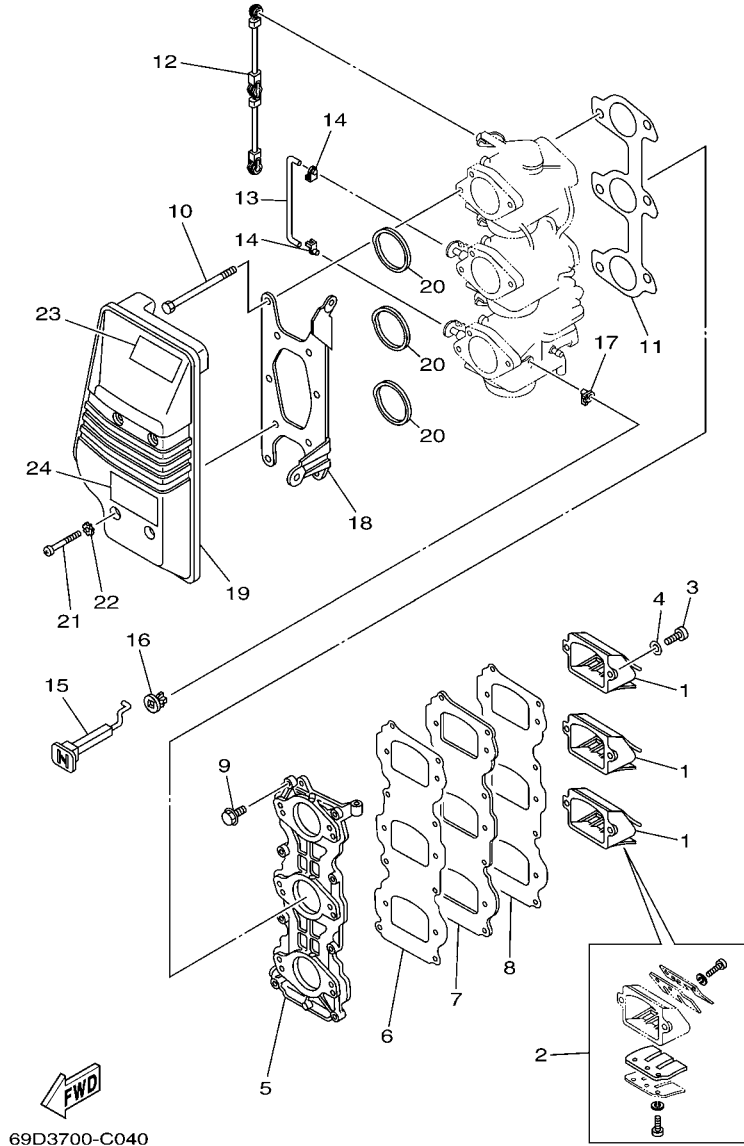

69D3700-C040

FIG. 4 INTAKE

ADMISION

REF. NO.	PART NO. CODIGO Nº	DESCRIPTION DESCRIPCION	MHD	WHD	WD	REMARKS OBSERVACIONES
1	6H2-13610-00	REED VALVE ASSY VALVULA DE LAMINAS COMPLETA	3	3	3	
2	688-W0004-00	.REED SET .JUEGO DE VALVULAS DE LENGUETA	1	1	1	
3	97880-05016	SCREW, PAN HEAD TORNILLO DE CABEZA CON PLANA	6	6	6	
4	92990-05600	WASHER, PLATE ARANDELA PLANA	6	6	6	
5	6H3-13641-03-94	MANIFOLD 1 MULTIPLE 1	1	1	1	
6	6H3-13621-A1	GASKET, VALVE SEAT JUNTA, DE VALV.DE EMPAQUE	1	1	1	
7	6H3-13624-00-94	PLATE, REED VALVE PLACA DE VALVULA DE LAMINAS	1	1	1	
8	6H3-13622-A1	GASKET, VALVE SEAT EMPAQUE DE ASIENTO VALVULA	1	1	1	
9	90119-06MA3	BOLT, WITH WASHER TORNILLO CON ARANDELA	8	8	8	
10	97095-06095	BOLT PERNO	6	6	6	
11	6H3-14198-A1	GASKET EMPAQUE	1	1	1	
12	6H3-41217-00	ROD, ACCEL. LEVER VARILLA PALANCA ACELERADOR	1	1	1	
13	6H3-41257-00	ROD, CHOKE 2 VARILLA DE AHOGADOR	2	2	2	
14	661-41262-02	JOINT, CHOKE LEVER CONECTOR DE AHOGADOR	4	4	4	
15	6H3-41271-00	KNOB, CHOKE PERILLA AHOGADOR	1	1	1	
16	689-41273-00	GROMMET TAPON PROTECTOR	1	1	1	
17	661-41262-02	JOINT, CHOKE LEVER CONECTOR DE AHOGADOR	1	1	1	
18	6H3-14413-10	STAY SOPORTE	1	1	1	
19	6H3-14440-02	SILENCER ASSY, INTAKE SILENCIADOR COMPL DE ADMISION	1	1	1	
20	6H3-14457-01	SEAL SELLO	3	3	3	
21	97885-06045	SCREW, PAN HEAD TORNILLO A MUESCA	4	4	4	
22	90209-06M05	WASHER ARANDELA DE SEPARACION	4	4	4	
23	6A1-83625-41	MARK 5 MARCA 5	1	1	1	
24	6K5-14488-00	LABEL, CAUTION ETIQUETA PRECAUCION	1	1	1	

FIG. 5 CARBURETOR

CARBURADOR

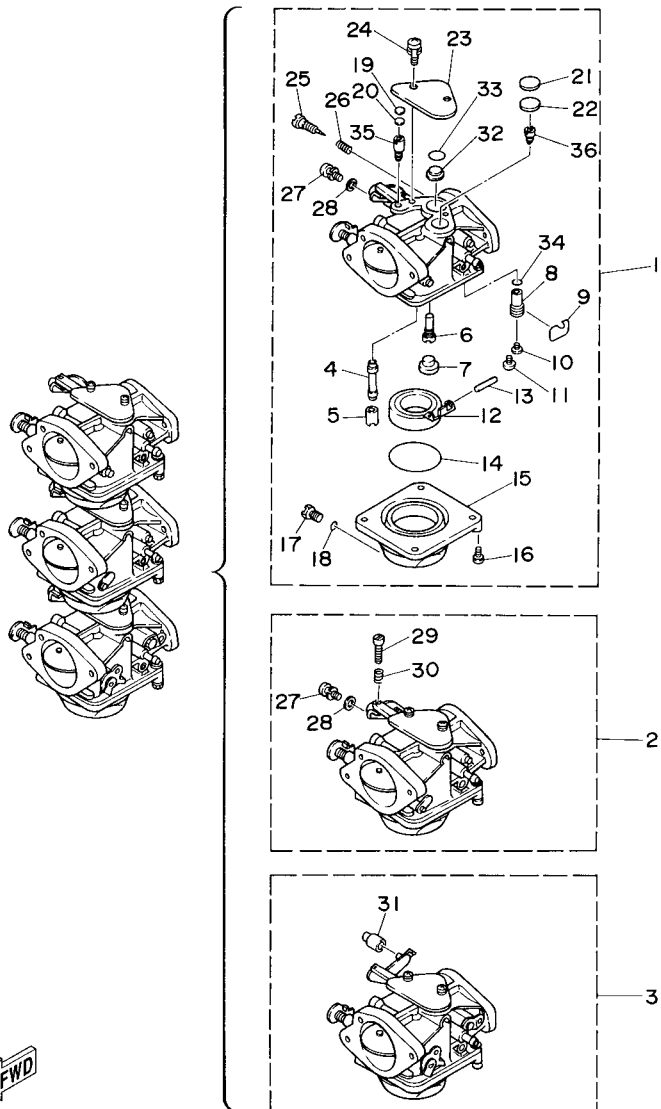



6K50100-4050

REF. NO.	PART NO. CODIGO Nº	DESCRIPTION DESCRIPCION	MHD	WHD	WD	REMARKS OBSERVACIONES
1	6K5-14301-03	CARBURETOR ASSY 1 CARBURADOR COMPLETO 1	1	1	1	
2	6K5-14302-03	CARBURETOR ASSY 2 CARBURADOR COMPLETO 2	1	1	1	
3	6K5-14303-03	CARBURETOR ASSY 3 CARBURADOR COMPLETO 3	1	1	1	
4	6H2-14947-02	.NOZZLE, MAIN .INYECTOR DE AGUJA	3	3	3	
5	676-14943-34	.JET, MAIN (#135) .INYECTOR PRINCIPAL (#135)	3	3	3	
6	6H4-14948-15	.JET, SLOW (#70) .INYECTOR (#70)	3	3	3	
7	676-14966-00	.CAP .TAPA	3	3	3	
8	6H3-14590-01	.NEEDLE VALVE ASSY .VALVULA DE AGUJA COMPLETA	3	3	3	
9	663-14159-00	.CLIP .PRESILLA	3	3	3	
10	676-14186-00	.PIN, FLOAT .PASADOR DE LA BOYA	3	3	3	
11	98580-04008	.SCREW, PAN HEAD .TORNILLO DE CABEZA CRUZADA	3	3	3	
12	6G1-14985-00	.FLOAT .BOIA	3	3	3	
13	688-14548-00	.PIN, FLOAT ARM .PASADOR DE BRAZO DE BOIA	3	3	3	
14	6G1-14984-00	.O-RING .EMPAQUE CAMARA DE BOIA	3	3	3	
15	6H2-14980-00	.BODY, FLOAT CHAMBER .CUERPO CAMARA DE BOIA	3	3	3	
16	97980-04114	.SCREW, WITH WASHER .TORNILLO, CON ARANDELA	12	12	12	
17	6H3-14992-00	.SCREW, DRAIN .TORNILLO, SEGURO	3	3	3	
18	93210-04230	.O-RING .ANILLO O	3	3	3	
19	663-14126-00	.GASKET .EMPAQUE	3	3	3	
20	663-14527-00	.PLATE .PLACA	3	3	3	
21	688-14126-00	.GASKET .EMPAQUE	3	3	3	
22	688-14527-00	.PLATE .PLACA	3	3	3	
23	6H2-14527-01	.PLATE .PLACA	3	3	3	
24	97980-05310	.SCREW, WITH WASHER .TORNILLO, CON ARANDELA	6	6	6	
25	692-14923-00	.SCREW, PILOT .TORNILLO DE AJUSTE	3	3	3	
26	679-14555-00	.SPRING .RESORTE	3	3	3	
27	6K5-14592-00	.SCREW .TORNILLO	2	2	2	#1,2 #1,2

FIG. 5 CARBURETOR

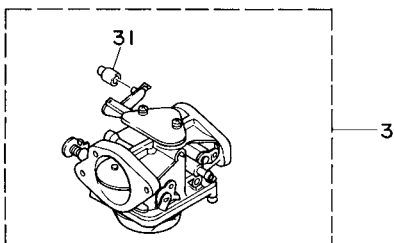
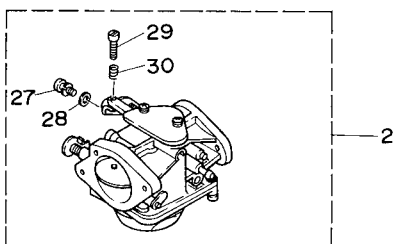
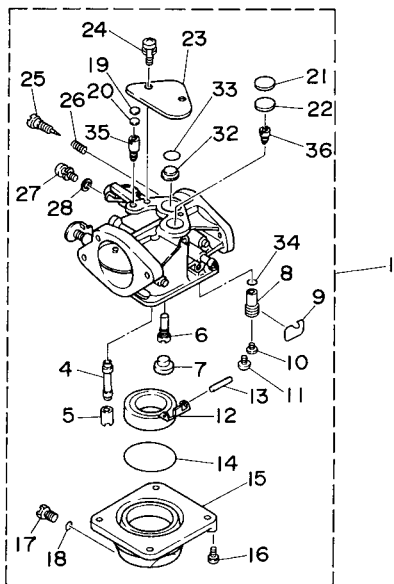
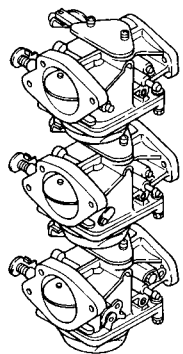
CARBURADOR



REF. NO.	PART NO. CODIGO Nº	DESCRIPTION DESCRIPCION	MHD	WHD	WD	REMARKS OBSERVACIONES
28	90201-05652	.WASHER, PLATE .ARANDELA PLANA	2	2	2	#1,2 #1,2
29	63V-14523-00	.SCREW, STOP .TORNILLO DE TOPE	1	1	1	#2 #2
30	90501-10326	.SPRING, COMPRESSION .RESORTE DE COMPRESION	1	1	1	#2 #2
31	6H2-14578-00	.COLLAR .COLLAR	1	1	1	#3 #3
32	6H3-14578-00	.PLATE .COLLAR	3	3	3	
33	93210-15M52	.O-RING .ANILLO O	3	3	3	
34	93210-04228	.O-RING .ANILLO O	3	3	3	
35	6K5-14945-36	.JET, AIR MAIN (#145) .INYECTOR (#145)	3	3	3	
36	6K5-14950-21	.JET, AIR SLOW (#85) .ESPREA DE AIRE PILOTO (#85)	3	3	3	



6K50100-4050

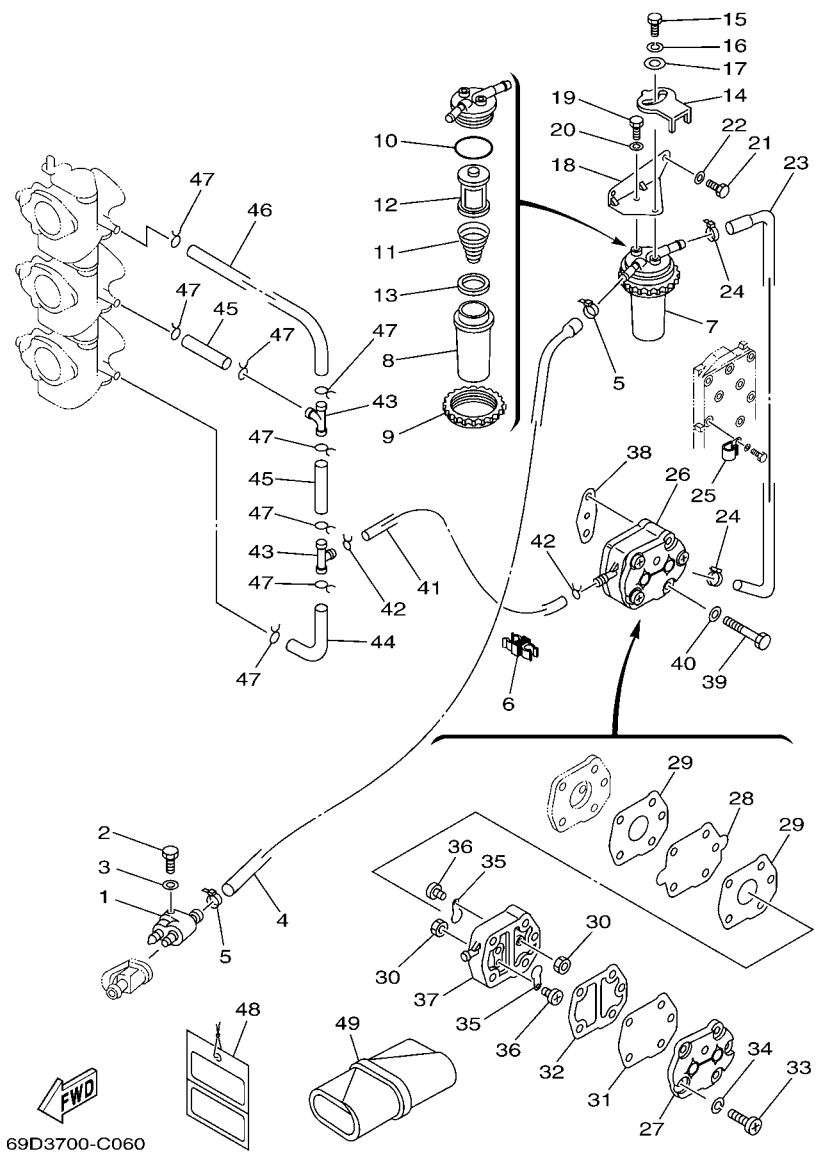

FIG. 6 FUEL

COMBUSTIBLE

REF. NO.	PART NO. CODIGO Nº	DESCRIPTION DESCRIPCION	MHD	WHD	WD	REMARKS OBSERVACIONES
1	6G1-24304-02	FUEL PIPE JOINT COMP. 1 CONECTOR MANGUERA COMBUST.1	1	1	1	
2	97095-06025	BOLT PERNO	1	1	1	
3	92995-06600	WASHER ARANDELA	1	1	1	
4	69D-24311-00	PIPE, FUEL 1 TUBO DE COMBUSTIBLE 1	1	1	1	
5	90465-11M10	CLAMP BRIDA	2	2	2	
6	90464-10M59	CLAMP BRIDA	1	1	1	
7	61A-24560-04	FILTER ASSY FILTRO COMPLETO	1	1	1	
8	61A-24521-00	.CUP, FILTER .COPA DE FILTRO	1	1	1	
9	65L-24531-01	.NUT .TUERCA	1	1	1	
10	61A-24564-00	.O-RING .ANILLO O	1	1	1	
11	61A-24577-01	.SPRING .RESORTE	1	1	1	
12	61A-24563-00	.ELEMENT, FILTER .ELEMENTO DEL FILTRO	1	1	1	
13	61A-24469-00	.FLOAT, WATER LEVEL .BOIA	1	1	1	
14	60H-24558-00	HOLDER, FILTER SOPORTE DE FILTRO	1	1	1	
15	97095-06016	BOLT PERNO	1	1	1	
16	92995-06100	WASHER, SPRING ARANDELA	1	1	1	
17	90201-06068	WASHER, PLATE ARANDELA PLANA	1	1	1	
18	69D-24566-01	BRACKET, FILTER SOPORTE DEL FILTRO	1	1	1	
19	97095-06014	BOLT PERNO	1	1	1	
20	92995-06600	WASHER ARANDELA	1	1	1	
21	97095-06016	BOLT PERNO	2	2	2	
22	92995-06600	WASHER ARANDELA	2	2	2	
23	69D-24312-00	PIPE 2 TUBO 2	1	1	1	
24	90465-11M10	CLAMP BRIDA	2	2	2	
25	90465-08M83	CLAMP BRIDA	1	1	1	
26	692-24410-00	FUEL PUMP ASSY BOMBA DE COMBUSTIBLE COMPLETA	1	1	1	
27	6A0-24413-00	.BODY 2 .CUERPO 2	1	1	1	

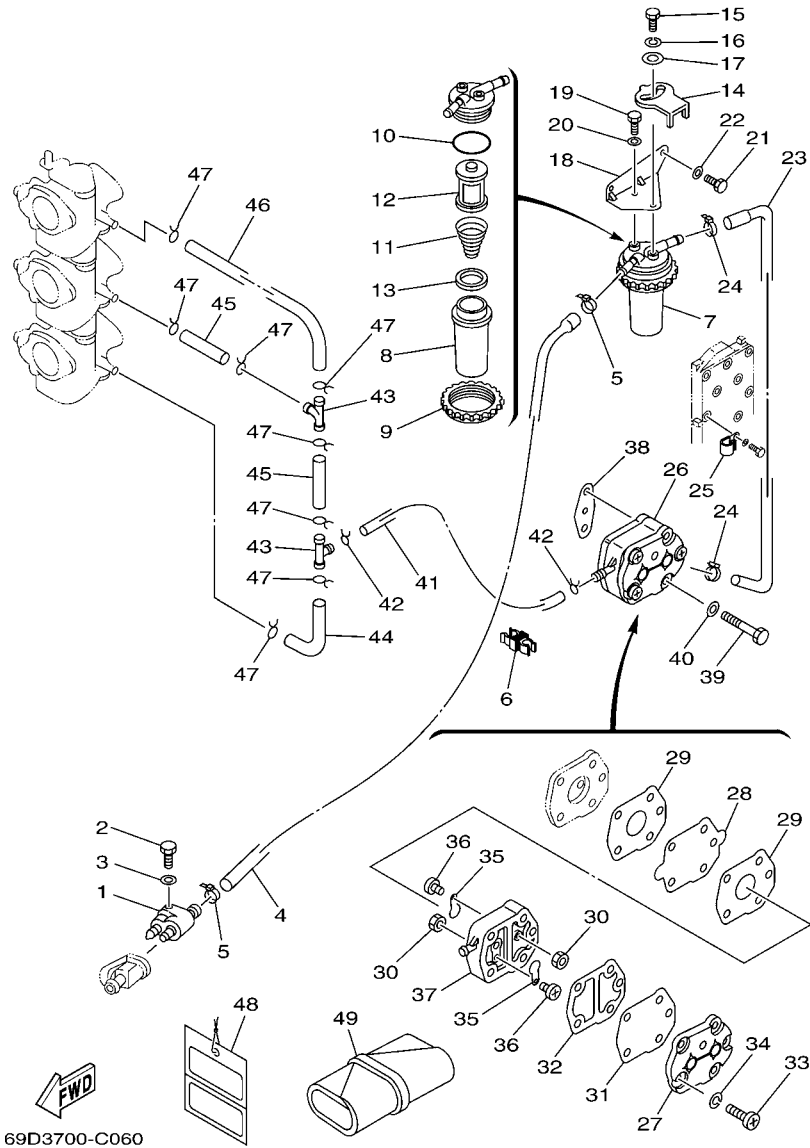

FIG. 6 FUEL

COMBUSTIBLE

REF. NO.	PART NO. CODIGO Nº	DESCRIPTION DESCRIPCION	MHD	WHD	WD	REMARKS OBSERVACIONES
28	692-24411-00	.DIAPHRAGM .DIAFRAGMA	1	1	1	
29	648-24434-01	.GASKET, BODY .EMPAQUE	2	2	2	
30	95380-03600	.NUT .TUERCA	2	2	2	
31	663-24411-00	.DIAPHRAGM .DIAFRAGMA	1	1	1	
32	648-24435-02	.GASKET, BODY 2 .EMPAQUE	1	1	1	
33	98503-05028	.SCREW, PAN HEAD .TORNILLO DE CABEZA DE CONO AC	3	3	3	
34	92990-05100	.WASHER, SPRING .ARANDELA PLANA	3	3	3	
35	6A0-24421-01	.VALVE, CHECK .VALVULA DE RETENCION	2	2	2	
36	6A0-14325-00	.SCREW, PAN HEAD .TORNILLO CABEZA REDONDA	2	2	2	
37	6A0-24412-02	.BODY 1 .CUERPO 1	1	1	1	
38	650-24431-A0	GASKET, FUEL PUMP 1 EMPAQUE BOMBA COMBUST 1	1	1	1	
39	97095-06040	BOLT PERNO	2	2	2	
40	92995-06600	WASHER ARANDELA	2	2	2	
41	90445-09072	HOSE (L120) TUBO (L120)	1	1	1	
42	90467-08004	CLIP PRESILLA	2	2	2	
43	688-24378-00	PIPE, JOINT 4 TUBO DE UNION 4	2	2	2	
44	6H3-24313-00	PIPE 3 TUBO 3	1	1	1	
45	90445-09220	HOSE (L30) TUBO (L30)	2	2	2	
46	6H3-24314-00	PIPE 4 TUBO 4	1	1	1	
47	90467-08004	CLIP PRESILLA	8	8	8	
48	61H-2819R-31	TAG, WARNING ETIQUETA DE ADVERTENCIA	1			FOR CAR FOR CAR
49	656-W2810-02	TOOL KIT JUEGO DE HERRAMIENTAS	1	1	1	

FIG. 7 STARTER

ARRANQUE

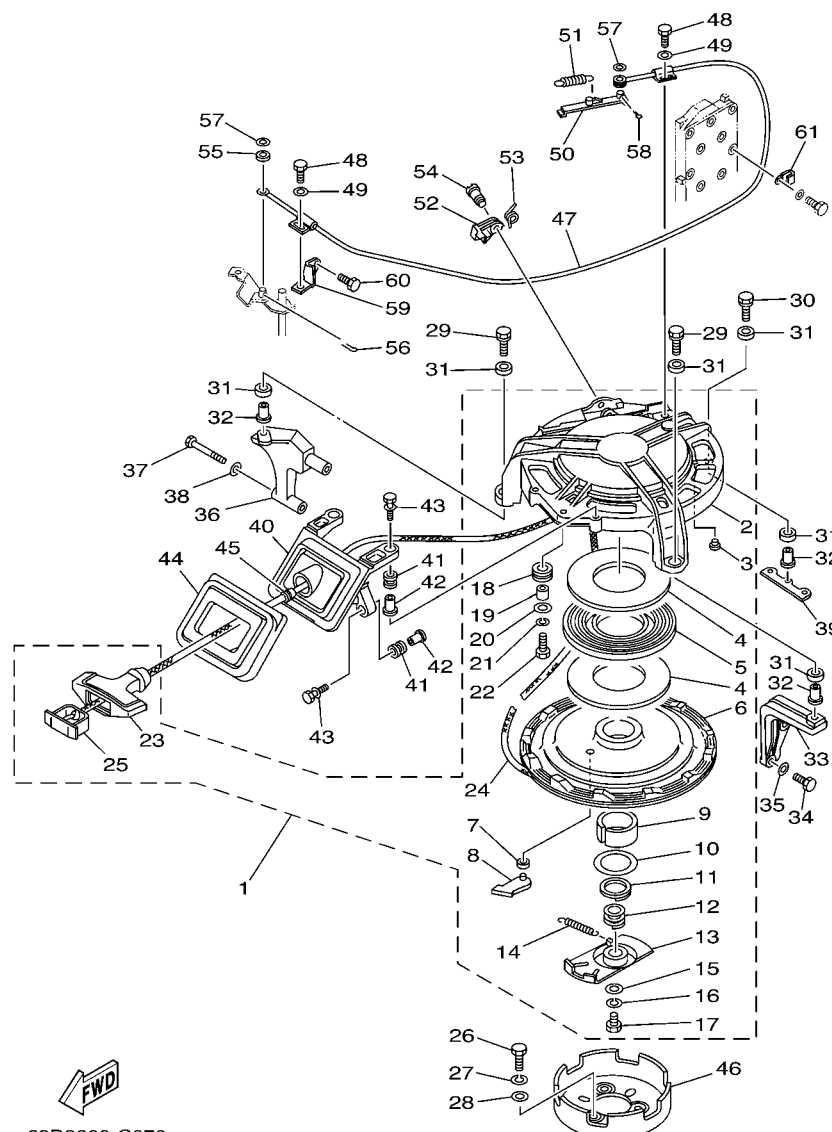

69D3200-C070

*1: CUT FROM 50M ROLLS, PART NO. 90890-44374, CUTTING LENGTH 2.3M

*1: CORTE DE UN RODILLO DE 50M , PARTS NUMERO 90890-44374, LARGO DEL CORTE 2.3M

REF. NO.	PART NO. CODIGO Nº	DESCRIPTION DESCRIPCION	MHD	WHD	WD	REMARKS OBSERVACIONES
1	692-W1571-02	STARTER ASSY ARRANQUE COMPLETO	1	1	1	
2	692-15711-00	.CASE, STARTER .CAJA DE ARRANQUE	1	1	1	
3	648-15773-00	.STAY 3 .SOPORTE 3	5	5	5	
4	663-15739-00	.WASHER, THRUST .ARANDELA DE EMPUJE AXIAL	2	2	2	
5	663-15713-00	.SPRING, STARTER .RESORTE DE ARRANQUE	1	1	1	
6	663-15714-01	.DRUM, SHEAVE .TAMBOR ROLDANA	1	1	1	
7	663-15764-00	.COLLAR 1 .COLLAR 1	1	1	1	
8	663-15741-02	.PAWL, DRIVE .TRINQUETE DE TRACCION	1	1	1	
9	663-15754-00	.BUSH 2 .BUJE 2	1	1	1	
10	663-15726-01	.WASHER, FLAT .ARANDELA PLANA	1	1	1	
11	663-15744-00	.CIRCLIP .SEGURO	1	1	1	
12	663-15715-00	.SPRING, FRICTION .RESORTE PLACA DE TRACCION	1	1	1	
13	663-15716-01	.PLATE, DRIVE .PLACA DE TRACCION	1	1	1	
14	663-15734-01	.SPRING, RETURN .RESORTE DE RETORNO	1	1	1	
15	663-15719-00	.WASHER, THRUST .ARANDELA DE EMPUJE	1	1	1	
16	92903-06100	.WASHER, SPRING .RONDANA SENCILLA	1	1	1	
17	97303-06016	.BOLT .TORNILLO	1	1	1	
18	663-15752-00	.ROLLER, WIRE .RODILLO DE CUERDA	1	1	1	
19	663-15753-00	.BUSH .BUJE	1	1	1	
20	663-15791-00	.WASHER, LOCK .EMBLEMA	1	1	1	
21	92903-06100	.WASHER, SPRING .RONDANA SENCILLA	1	1	1	
22	97303-06025	.BOLT .TORNILLO	1	1	1	
23	689-15755-01	.HANDLE, STARTER .MANIJA DE ARRANQUE	1	1	1	
24	*	.WIRE (L:2300MM) .CABLE (L:2300MM)	1	1	1	*1 *1
25	6F5-15779-02	.COVER .CUBIERTA	1	1	1	
26	97013-08012	BOLT PERNO	3	3	3	
27	92903-08100	WASHER, SPRING RONDANA SENCILLA	3	3	3	

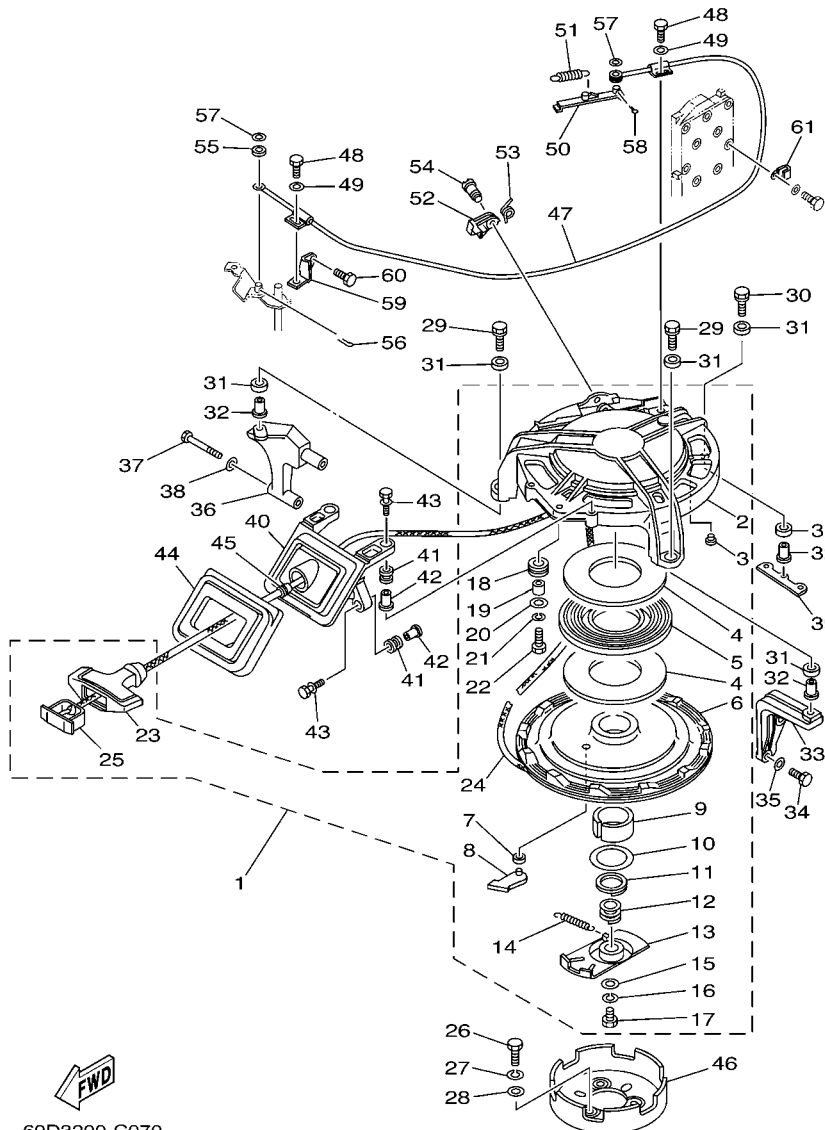

69D3200-C070

*1: CUT FROM 50M ROLLS, PART NO. 90890-44374, CUTTING LENGTH 2.3M

*1: CORTE DE UN RODILLO DE 50M , PARTS NUMERO 90890-44374, LARGO DEL CORTE 2.3M

FIG. 7 STARTER

ARRANQUE

REF. NO.	PART NO. CODIGO Nº	DESCRIPTION DESCRIPCION	MHD	WHD	WD	REMARKS OBSERVACIONES
28	92903-08600	WASHER, PLATE RONDANA SENCILLA	3	3	3	
29	90119-08087	BOLT, WITH WASHER TORNILLO CON ARANDELA	2	2	2	
30	90119-08M32	BOLT, WITH WASHER TORNILLO CON ARANDELA	1	1	1	
31	90385-12M04	BUSH BUJE	6	6	6	
32	90387-08M05	COLLAR ESPACIADOR	3	3	3	
33	6K5-15771-00-94	STAY 1 SOPORTE 1	1	1	1	
34	97013-06025	BOLT PERNO	2	2	2	
35	92903-06600	WASHER, PLATE RONDANA SENCILLA	2	2	2	
36	6K5-15772-00-94	STAY 2 SOPORTE 2	1	1	1	
37	97013-06055	BOLT PERNO	2	2	2	
38	92903-06600	WASHER, PLATE RONDANA SENCILLA	2	2	2	
39	6K5-15773-01	STAY 3 SOPORTE 3	1	1	1	
40	6K5-15758-01-94	GUIDE, ROPE GUIA DE CUERDA	1	1	1	
41	6A0-82317-00	DAMPER, IGNITION COIL AMORTIGUADOR BOBINA ENCENDIDO	4	4	4	
42	90387-06119	COLLAR ESPACIADOR	4	4	4	
43	90119-06M65	BOLT, WITH WASHER TORNILLO CON ARANDELA	4	4	4	
44	6K5-15762-00	SEAL, RUBBER 2 SELLO DE GOMA 2	1	1	1	
45	697-15789-00	DAMPER AMORTIGUADOR	1	1	1	
46	6K5-15723-00	PULLEY, STARTER POLEA DE ARRANQUE	1	1	1	
47	6K5-15770-01	CABLE COMP., STARTER STOP CABLECOMPL DE SEGURO ARRANQUE	1	1	1	
48	97095-06012	BOLT PERNO	2	2	2	
49	92995-06600	WASHER ARANDELA	2	2	2	
50	663-15735-01	GUIDE, CAM GUIA DE LEVA	1	1	1	
51	90506-08M23	SPRING, TENSION RESORTE DE TENSION	1	1	1	
52	663-15794-00	STOPPER TOPE	1	1	1	
53	90508-12015	SPRING, TORSION RESORTE DE TORSION	1	1	1	
54	90149-05095	SCREW TORNILLO DE REGLAJE	1	1	1	

FIG. 7 STARTER

ARRANQUE

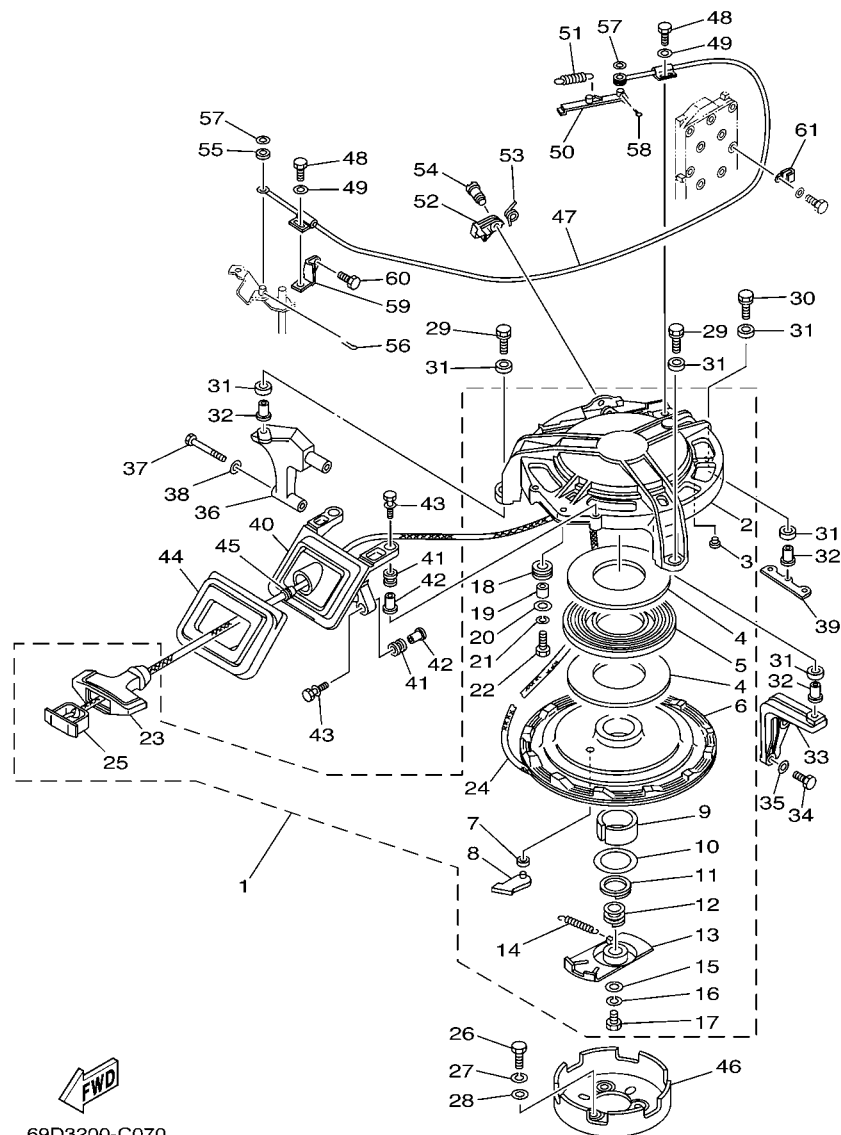

69D3200-C070

*1: CUT FROM 50M ROLLS, PART NO. 90890-44374, CUTTING LENGTH 2.3M

*1: CORTE DE UN RODILLO DE 50M , PARTS NUMERO 90890-44374, LARGO DEL CORTE 2.3M

REF. NO.	PART NO. CODIGO Nº	DESCRIPTION DESCRIPCION	MHD	WHD	WD	REMARKS OBSERVACIONES
55	663-15736-00	RING, RETAINING 1 ANILLO DE RETEN	1	1	1	
56	90468-18008	CLIP PRESILLA	1	1	1	
57	92903-06200	WASHER, PLAIN RONDANA SENCILLA	2	2	2	
58	91490-16012	PIN, COTTER CHAVETA	1	1	1	
59	6K5-15774-00	STAY 4 SOPORTE 4	1	1	1	
60	97013-06012	BOLT PERNO	1	1	1	
61	90465-06M90	CLAMP BRIDA	1	1	1	

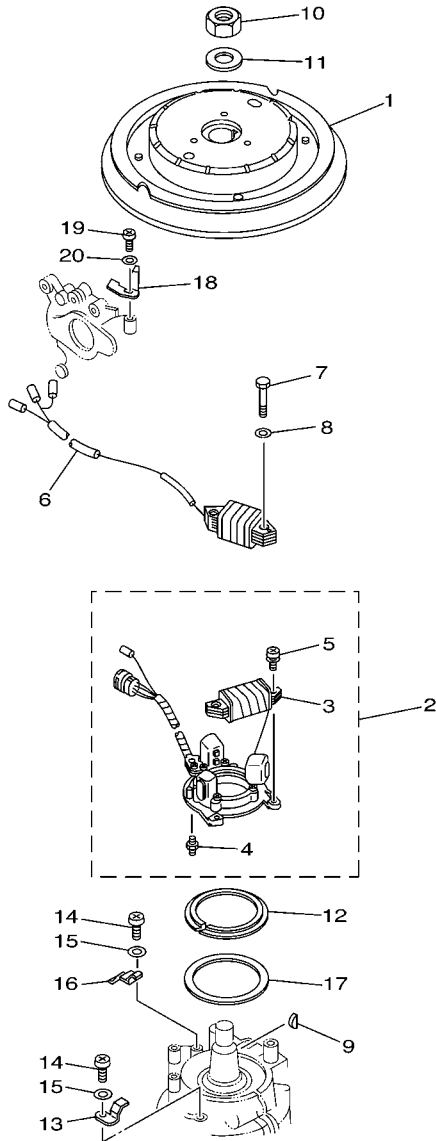

69D0300-1080

FIG. 8 GENERATOR

GENERADOR

REF. NO.	PART NO. CODIGO Nº	DESCRIPTION DESCRIPCION	MHD	WHD	WD	REMARKS OBSERVACIONES
1	6K5-85550-10	ROTOR ASSY ROTOR COMPLETO	1			
	6K5-85550-A0	ROTOR ASSY ROTOR COMPLETO		1	1	
2	6H3-85510-A1	STATOR ASSY ESTATOR COMPLETO	1	1	1	
3	6H3-85520-00	.COIL, CHARGE .BOBINA DE CARGA	1	1	1	
4	663-85518-00	.JOINT, BALL .CONECTOR	1	1	1	
5	97902-05125	.SCREW, WITH WASHER .TORNILLO, CON ARANDELA	2	2	2	
6	6H3-85533-A0	COIL, LIGHTING BOBINA DE LUZ	1	1	1	
7	97013-06030	BOLT PERNO	2	2	2	
8	92903-06600	WASHER, PLATE RONDANA SENCILLA	2	2	2	
9	90280-05015	KEY, WOODRUFF CUNA WOODRUFF	1	1	1	
10	90170-20137	NUT TUERCA	1	1	1	
11	90201-21M18	WASHER, PLATE ARANDELA PLANA	1	1	1	
12	6H4-41611-00	RETAINER, MAGNETO BASE RETENEDOR BASE MAGNETO	1	1	1	
13	6H3-41612-00	RETAINER, MAGNETO BASE RETENEDOR BASE MAGNETO	2	2	2	
14	97885-06012	SCREW, PAN HEAD TORNILLO A MUESCA	3	3	3	
15	92995-06600	WASHER ARANDELA	3	3	3	
16	6H3-41612-10	RETAINER, MAGNETO BASE RETENEDOR BASE MAGNETO	1	1	1	
17	6K5-41618-00	WASHER, MAGNETO RONDANA, MAGNETO	1	1	1	
18	6K5-81332-60	PLATE, TIMING PLACA REGULADOR DE TIEMPO	1			
	6K5-81332-00	PLATE, TIMING PLACA REGULADOR DE TIEMPO		1	1	
19	97885-06010	SCREW, PAN HEAD TORNILLO A MUESCA	1	1	1	
20	92995-06600	WASHER ARANDELA	1	1	1	

FIG. 9 ELECTRICAL 1

EQUIPO ELECTRICO 1

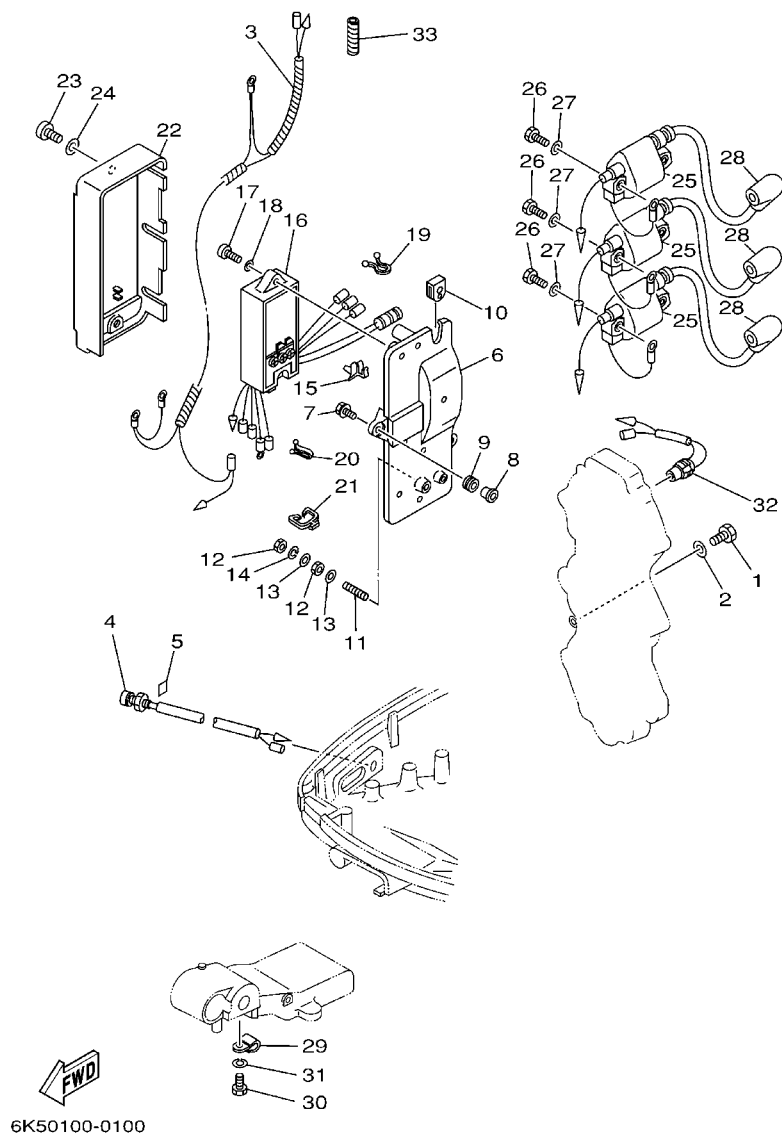

REF. NO.	PART NO. CODIGO Nº	DESCRIPTION DESCRIPCION	MHD	WHD	WD	REMARKS OBSERVACIONES
1	97013-06012	BOLT PERNO	1	1		
2	92903-06600	WASHER, PLATE RONDANA SENCILLA	1	1		
3	6K5-82531-00	WIRE, LEAD CABLE CONDUCTOR	1			
4	6H4-85411-00	OVERHEAT WARNING LAMP CALENTAR DEMASIADO DEL ALARMA	1	1		
5	6H4-85415-00	MARK, SIGNAL LAMP MARCO DE FOCO DE SENAL	1	1		
6	6H3-85542-00-94	BRACKET SOPORTE	1	1	1	
7	90105-06M14	BOLT FLANGE TORNILLO	3	3	3	
8	90387-06M43	COLLAR ESPACIADOR	3	3	3	
9	90480-13M24	GROMMET TAPON	3	3	3	
10	6H3-81922-00	GROMMET TAPON PROTECTOR	1	1	1	
11	90116-06M07	BOLT, STUD ESPARRAGO	1	1	1	
12	95380-06700	NUT TUERCA	2	2	2	
13	92990-06200	WASHER, PLAIN ARANDELA PLANA	2	2	2	
14	92990-06100	WASHER, SPRING ARANDELA PLANA	1	1	1	
15	90464-04M12	CLAMP BRIDA	1	1	1	
16	6H3-85540-11	C.D.I. UNIT ASSY UNIDAD C.D.I. COMPLETA	1	1	1	
17	97880-06025	SCREW, PAN HEAD TORNILLO DE CABEZA CON PLANA	2	2	2	
18	92990-06600	WASHER, PLATE ARANDELA PLANA	2	2	2	
19	90464-08M07	CLAMP BRIDA	1	1	1	
20	90464-12M17	CLAMP BRIDA	1	1	1	
21	90464-07M10	CLAMP BRIDA	1	1	1	
22	6H3-81916-00	COVER, TERMINAL CUBIERTA DE TERMINAL	1	1	1	
23	97885-06012	SCREW, PAN HEAD TORNILLO A MUESCA	2	2	2	
24	92995-06600	WASHER ARANDELA	2	2	2	
25	6H3-85570-10	IGNITION COIL ASSY BOBINA DE IGNICION COMPLETO	3	3	3	
26	97013-06025	BOLT PERNO	6	6	6	
27	92903-06600	WASHER, PLATE RONDANA SENCILLA	6	6	6	

FIG. 9 ELECTRICAL 1

EQUIPO ELECTRICO 1

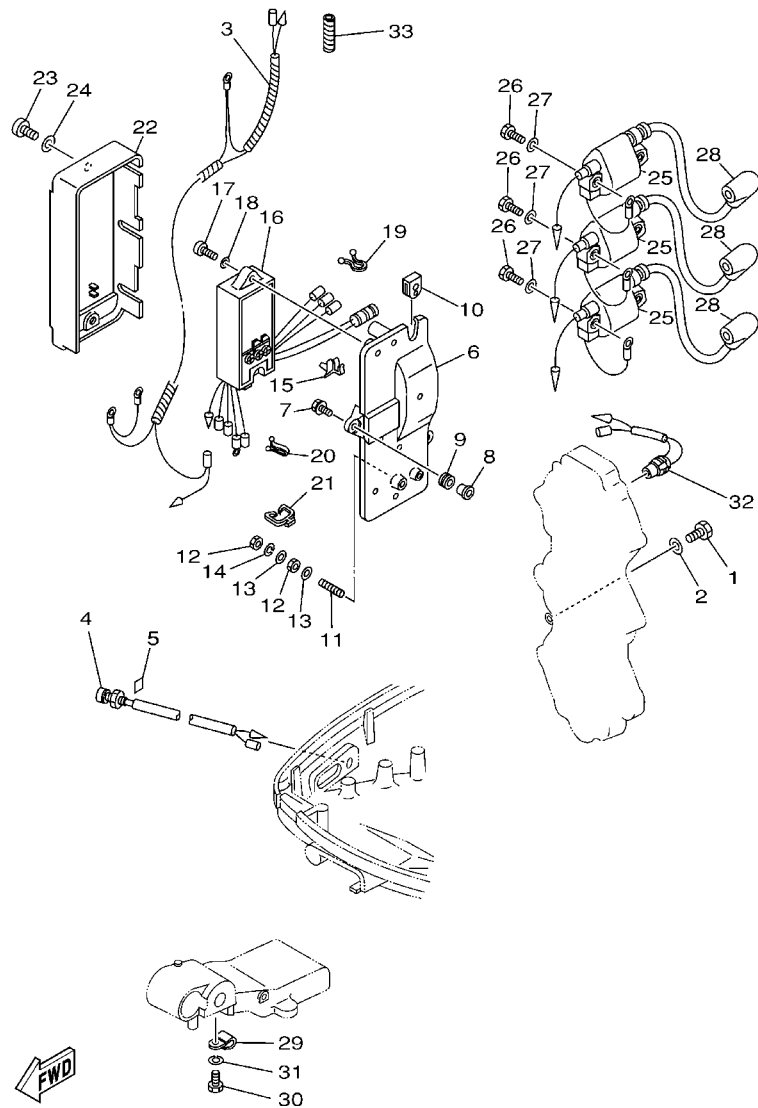

FWD
6K50100-0100

REF. NO.	PART NO. CODIGO Nº	DESCRIPTION DESCRIPCION	MHD	WHHD	WD	REMARKS OBSERVACIONES
28	663-82370-01	PLUG CAP ASSY TAPON DE BUJIA COMPLT	3	3	3	
	6G1-82370-21	PLUG CAP ASSY TAPON DE BUJIA COMPLT	3			FOR CAR
	63M-82370-01	PLUG CAP ASSY TAPON DE BUJIA COMPLT		3		FOR YEM
29	90465-06M90	CLAMP BRIDA	1			
30	97013-06012	BOLT PERNO	1			
31	92903-06100	WASHER, SPRING RONDANA SENCILLA	1			
32	688-82560-10	THERMO SWITCH ASSY INTER. DE TERMO	1	1	1	
33	90446-10M02	HOSE TUBO RESEIRADERO	1	1	1	

FIG. 10 ELECTRICAL 2

EQUIPO ELECTRICO 2

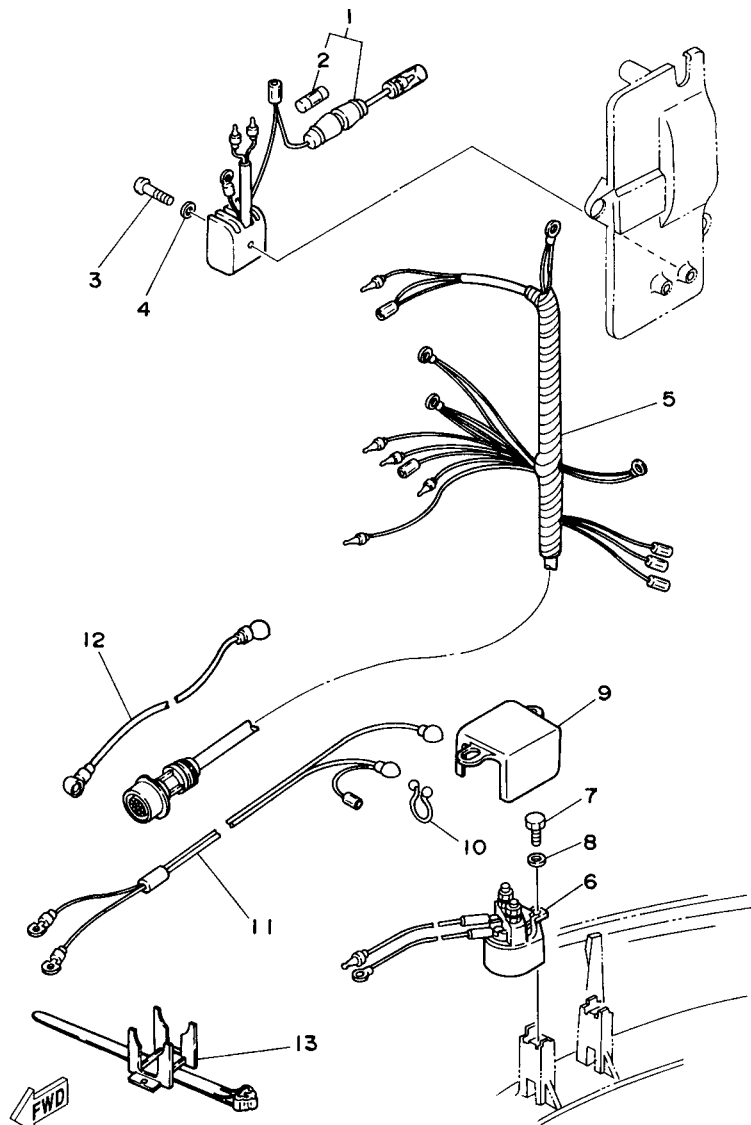

6K50100-4110

REF. NO.	PART NO. CODIGO Nº	DESCRIPTION DESCRIPCION	MHD	WHD	WD	REMARKS OBSERVACIONES
1	6G1-81970-61	RECTIFIER ASSY RECTIFICADOR COMPLETO		1		
2	6G1-82151-00	.FUSE (10A) .FUSIBLE (10A)		1		
3	97880-05025	SCREW, PAN HEAD TORNILLO DE CABEZA CON PLANA		1		
4	92990-05600	WASHER, PLATE ARANDELA PLANA		1		
5	6K5-82590-10	WIRE HARNESS ASSY CONJUNTO DE CABLES		1		
6	688-81950-10	RELAY ASSY RELE COMPLETO		1		
7	97013-06016	BOLT PERNO		1		
8	92903-06600	WASHER, PLATE RONDANA SENCILLA		1		
9	6H3-82164-00	CASE 2 BUJE		1		
10	90464-15M11	CLAMP BRIDA		1		
11	6H3-82105-01	WIRE HARNESS ARNES DE CABLES		1		
12	6H3-82117-00	WIRE, LEAD CABLE CONDUCTOR		1		
13	688-82594-00	CLAMP GRAMPA		1		
						FOR YEM FOR YEM

FIG. 11 ELECTRICAL 3

EQUIPO ELECTRICO 3

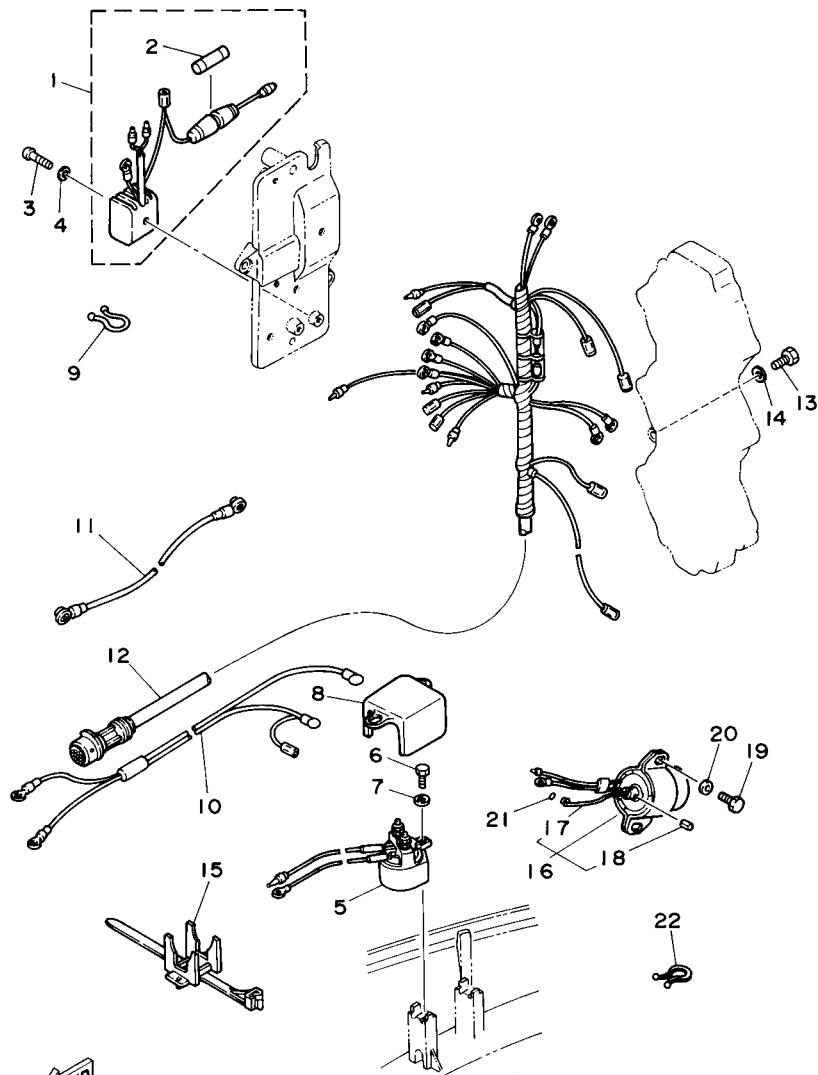

FWD
6K50200-4110

REF. NO.	PART NO. CODIGO Nº	DESCRIPTION DESCRIPCION	MHD	WHD	WD	REMARKS OBSERVACIONES
1	6G1-81970-61	RECTIFIER ASSY RECTIFICADOR COMPLETO			1	
2	6G1-82151-00	.FUSE (10A) .FUSIBLE (10A)			1	
3	97880-05025	SCREW, PAN HEAD TORNILLO DE CABEZA CON PLANA			1	
4	92990-05600	WASHER, PLATE ARANDELA PLANA			1	
5	688-81950-10	RELAY ASSY RELE COMPLETO			1	
6	97013-06016	BOLT PERNO			1	
7	92903-06600	WASHER, PLATE RONDANA SENCILLA			1	
8	6H3-82164-00	CASE 2 BUJE			1	
9	90464-15M11	CLAMP BRIDA			1	
10	6H3-82105-01	WIRE HARNESS ARNES DE CABLES			1	
11	6H3-82117-00	WIRE, LEAD CABLE CONDUCTOR			1	
12	6H3-82590-01	WIRE HARNESS ASSY CONJUNTO DE CABLES			1	
13	97013-06012	BOLT PERNO			1	
14	92903-06600	WASHER, PLATE RONDANA SENCILLA			1	
15	688-82594-00	CLAMP GRAMPA			1	
16	6H3-86110-02	SOLENOID SOLENOIDE			1	
17	6H3-86116-00	.WIRE, PULL .ALAMBRE-JALADOR			1	
18	91690-30010	.PIN, SPRING .PASADOR DE RESORTE			1	
19	97013-06016	BOLT PERNO			2	
20	92903-06600	WASHER, PLATE RONDANA SENCILLA			2	
21	93210-03261	O-RING ANILLO O			1	
22	90465-18147	CLAMP BRIDA			1	

FIG. 12 ELECTRICAL 4

EQUIPO ELECTRICO 4

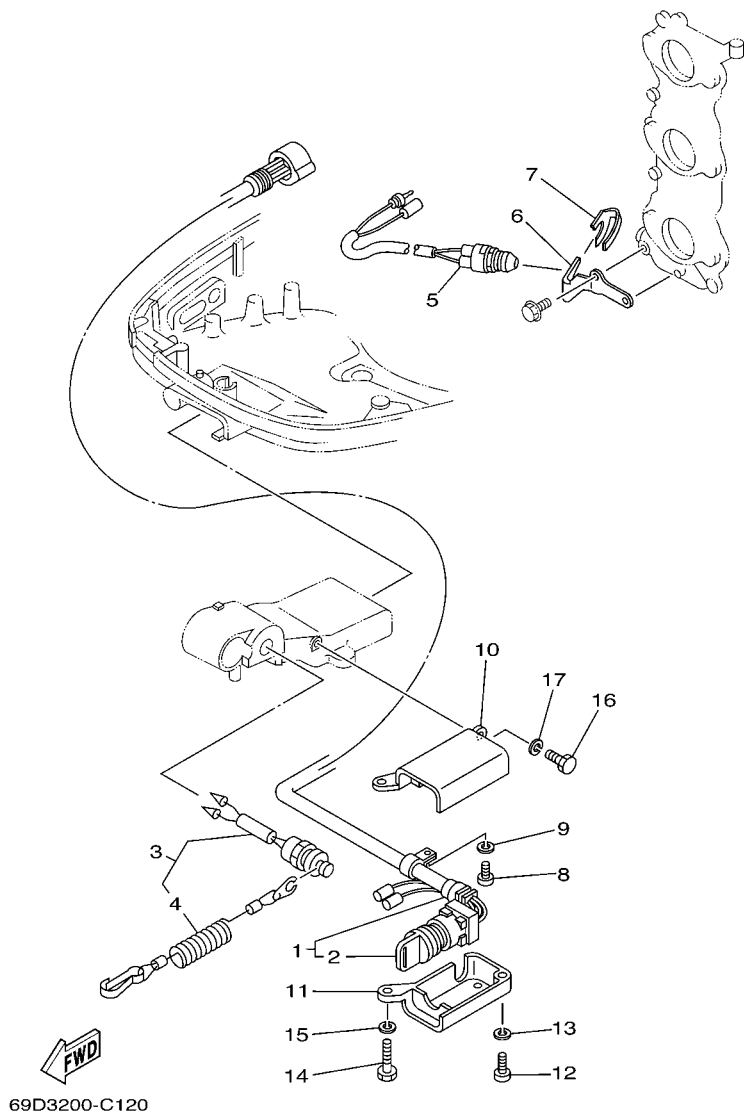

REF. NO.	PART NO. CODIGO Nº	DESCRIPTION DESCRIPCION	MHD	WHD	WD	REMARKS OBSERVACIONES
1	6H3-82510-20	MAIN SWITCH ASSY CONJUNTO DE LLAVE IGNICION		1		
2	676-82577-00	.CAP, KEY .TAPA		1		
3	688-82575-10	ENGINE STOP SWITCH ASSY INTERRUPTOR DE PARADA COMPL		1		
4	682-82556-00	.LANYARD, STOP SWITCH .RETENER		1		
5	6H3-82540-00	NEUTRAL SWITCH ASSY INTERRUPTOR NEUTRAL COMPL		1		
6	6H3-82554-00	STAY, NEUTRAL SWITCH SOPORTE INTERRUPTOR DE NEUTRAL		1		
7	663-82555-01	DAMPER, MAIN SWITCH 1 AMORT.DE INTER.PPAL.1		1		
8	97885-06012	SCREW, PAN HEAD TORNILLO A MUESCA		1		
9	92995-06100	WASHER, SPRING ARANDELA		1		
10	697-8252E-02-4D	COVER, MAIN SWITCH 1 CUBIELA INTERRUPTOR PRINC.1		1		
11	697-8252F-02-4D	COVER, MAIN SWITCH 2 CUBIELA INTERRUPTOR PRINC.2		1		
12	97880-06025	SCREW, PAN HEAD TORNILLO DE CABEZA CON PLANA		1		
13	92990-06100	WASHER, SPRING ARANDELA PLANA		1		
14	97013-06030	BOLT PERNO		1		
15	92903-06100	WASHER, SPRING RONDANA SENCILLA		1		
16	97013-06020	BOLT PERNO		1		
17	92903-06100	WASHER, SPRING RONDANA SENCILLA		1		

FIG. 13 ELECTRICAL 5

EQUIPO ELECTRICO 5

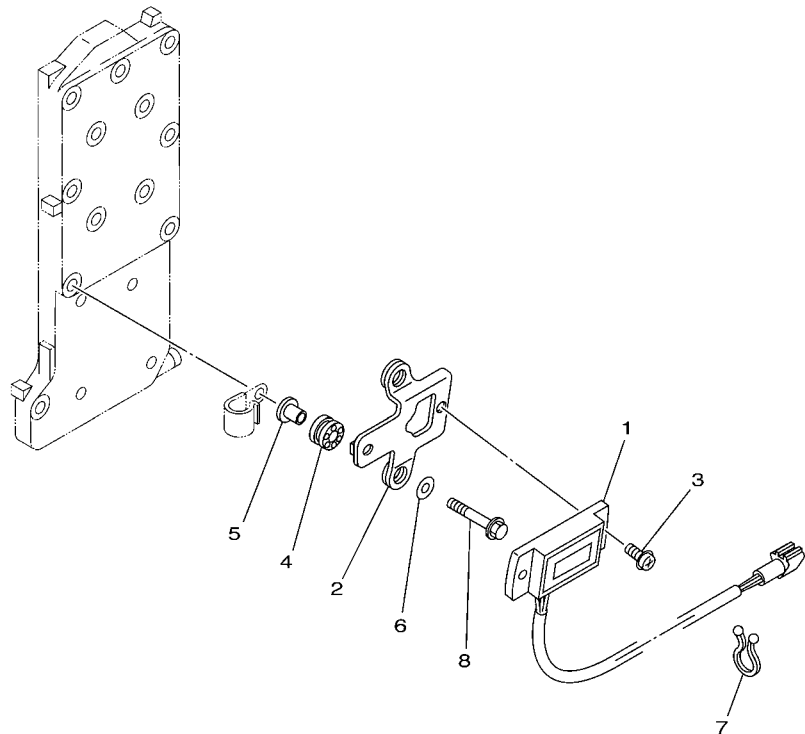

REF. NO.	PART NO. CODIGO Nº	DESCRIPTION DESCRIPCION	MHD	WHD	WD	REMARKS OBSERVACIONES
1	6Y5-83504-20	HOUR METER ASSY MEDIDOR DE HORAS COMPLETO		1		FOR YEM FOR YEM
2	69D-83519-00	BRACKET, METER SOPORTE DE MEDIDOR		1		FOR YEM FOR YEM
3	90159-05M13	SCREW, WITH WASHER TORNILLO CON VALONA		2		FOR YEM FOR YEM
4	64J-85516-00	SPACER ESPACIADOR		2		FOR YEM FOR YEM
5	69M-42758-00	COLLAR COLLAR		2		FOR YEM FOR YEM
6	90201-06M05	WASHER, PLATE ARANDELA PLANA		2		FOR YEM FOR YEM
7	90464-15M11	CLAMP BRIDA		1		FOR YEM FOR YEM
8	90119-06027	BOLT, WITH WASHER TORNILLO CON ARANDELA		2		FOR YEM FOR YEM

69D3200-C130

FIG. 14 STARTING MOTOR

MOTOR DE ARRANQUE

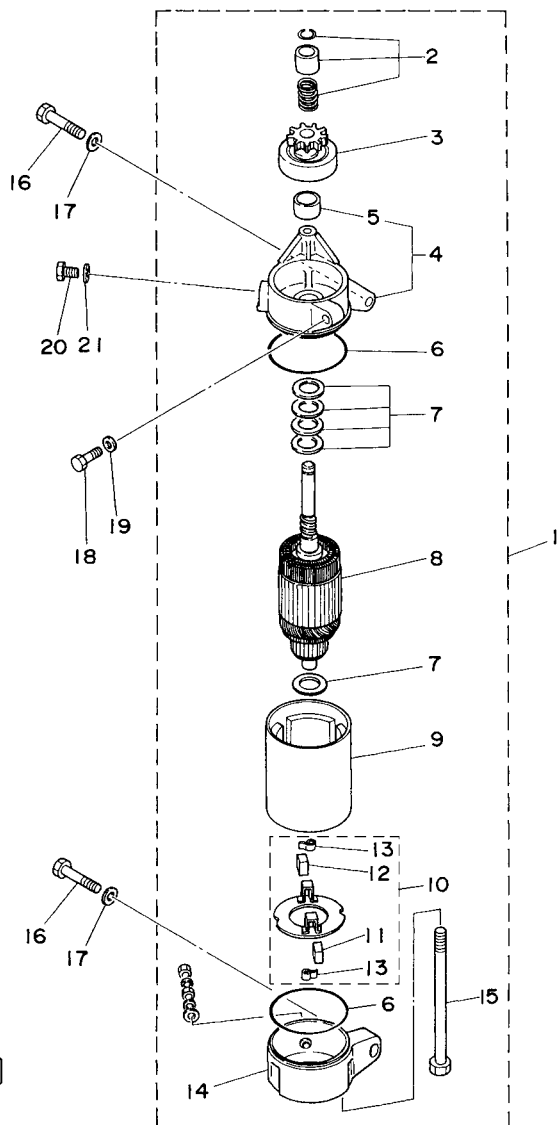

69D3200-C140

REF. NO.	PART NO. CODIGO Nº	DESCRIPTION DESCRIPCION	MHD	WHD	WD	REMARKS OBSERVACIONES
1	6H3-81800-11	STARTING MOTOR ASSY MOTOR DE ARRANQUE COMPLETO		1	1	
2	689-81857-11	.PINION STOPPER SET .JUEGO TAPON PINON		1	1	
3	6H3-81807-10	.GEAR ASSY, STARTING MOTOR .PINON CONJUNTO		1	1	
4	6H3-81830-10	.FRONT BRACKET ASSY .SOPORTE DELANTERO COMPLETO		1	1	
5	689-81831-00	..METAL, FRONT ..METAL, DELANTERO		1	1	
6	689-81847-11	.O-RING .ANILLO GOMA		2	2	
7	689-81809-11	.WASHER KIT .JUEGO DE ARANDELA		1	1	
8	689-81850-12	.ARMATURE ASSY .INDUCIDO COMPLETO		1	1	
9	6H3-81810-10	.STATOR ASSY .ESTATOR COMPLETO		1	1	
10	689-81840-11	.BRUSH HOLDER ASSY .SOSTEN DE ESCOBILLA COMPLETO		1	1	
11	689-81812-11	..BRUSH 2 ..ESCOBILLA 2		1	1	
12	689-81811-11	..BRUSH 1 ..ESCOBILLA 1		1	1	
13	689-81813-10	..SPRING, BRUSH ..RESORTE DE ESCOBILLA		2	2	
14	6H3-81820-11	.REAR BRACKET ASSY .CUBIERTA TRASERA COMPL		1	1	
15	689-81826-10	.BOLT ..PERNO		2	2	
16	97013-08035	BOLT PERNO		2	2	
17	92903-08600	WASHER, PLATE RONDANA SENCILLA		2	2	
18	97013-06025	BOLT PERNO		1	1	
19	92903-06600	WASHER, PLATE RONDANA SENCILLA		1	1	
20	97013-08016	BOLT PERNO		1	1	
21	92903-08600	WASHER, PLATE RONDANA SENCILLA		1	1	

FIG. 15 BOTTOM COWLING

CUBIERTA INFERIOR

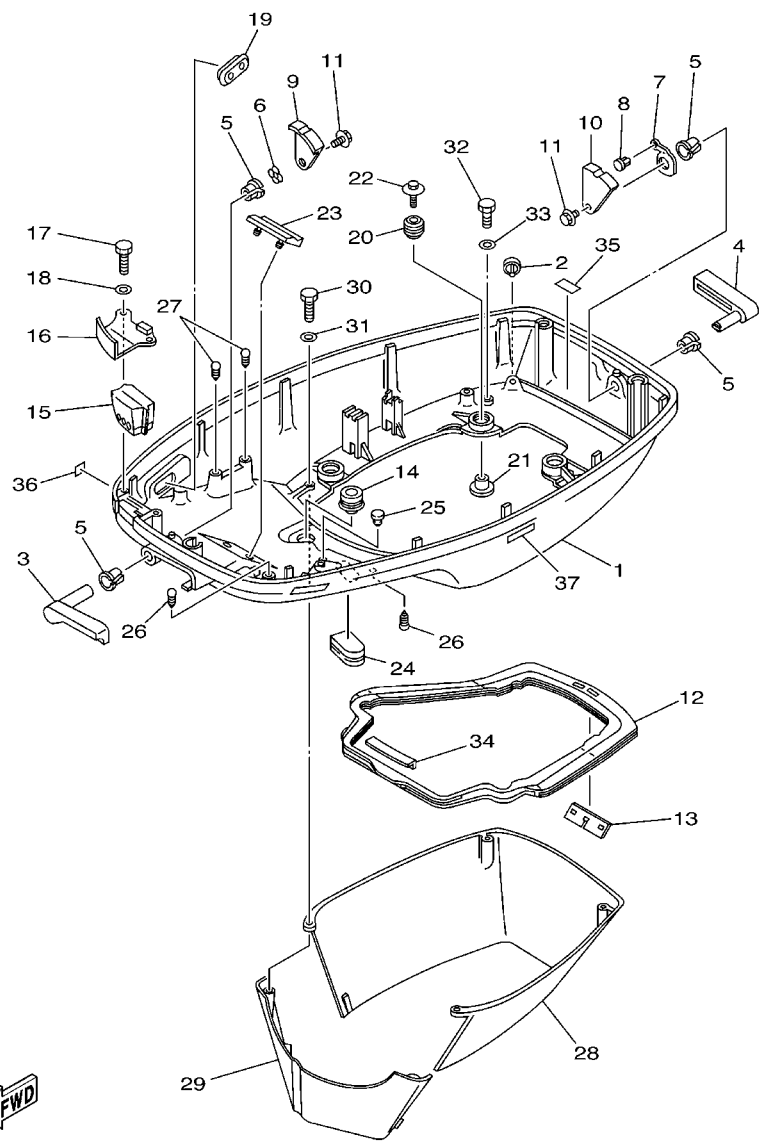

69D1300-2100

REF. NO.	PART NO. CODIGO Nº	DESCRIPTION DESCRIPCION	MHD	WHHD	WD	REMARKS OBSERVACIONES
1	6H3-42711-15-4D	COWLING, BOTTOM 1 CUBIERTA INFERIOR 1	1	1		
	6H3-42711-06-4D	COWLING, BOTTOM 1 CUBIERTA INFERIOR 1			1	
2	69D-44391-00	NIPPLE, HOSE NIPLE MANGUERA	1	1	1	
3	6H3-42815-01-4D	LEVER, CLAMP PALANCA ABRAZADERA	1	1	1	
4	6H3-42817-01-4D	LEVER, CLAMP PALANCA ABRAZADERA	1	1	1	
5	90386-13M38	BUSH BUJE	4	4	4	
6	90206-13M10	WASHER, WAVE ARANDELA ONDULADA	1	1	1	
7	6H3-42813-00	SPRING, CLAMP LEVER RESORTE	1	1	1	
8	90269-04M03	RIVET REMACHE	1	1	1	
9	6H3-42816-00	LEVER, CLAMP PALANCA ABRAZADERA	1	1	1	
10	6H3-42818-00	LEVER, CLAMP PALANCA, ABRAZADERA	1	1	1	
11	90119-06M09	BOLT, WITH WASHER TORNILLO CON ARANDELA	2	2	2	
12	6H3-42716-02	RUBBER, SEAL 1 SELLO DE GOMA 1	1	1	1	
13	6K5-42717-00	RUBBER, SEAL 2 GOMA	1	1	1	
14	6E5-42724-00	GROMMET TAPON	1	1	1	
15	6K5-42725-00	GROMMET TAPON	1			
	6H3-42725-20	GROMMET TAPON		1		
	6H3-42725-00	GROMMET TAPON			1	
16	6H3-42738-01-5B	PLATE, FITTING PLACA DE AJUSTE	1	1	1	
17	97095-06016	BOLT PERNO	2	2	2	
18	92995-06600	WASHER ARANDELA	2	2	2	
19	6H3-42727-00	GROMMET TAPON	1	1	1	
20	90480-09M12	GROMMET TAPON	4	4	4	
21	90387-06M69	COLLAR ESPACIADOR	4	4	4	
22	90119-06M61	BOLT, WITH WASHER TORNILLO CON ARANDELA	4	4	4	
23	6H3-42768-00	DAMPER AMORTIGUADOR	1	1	1	
24	6H4-42726-00	GROMMET TAPON	1	1	1	

FIG. 15 BOTTOM COWLING

CUBIERTA INFERIOR

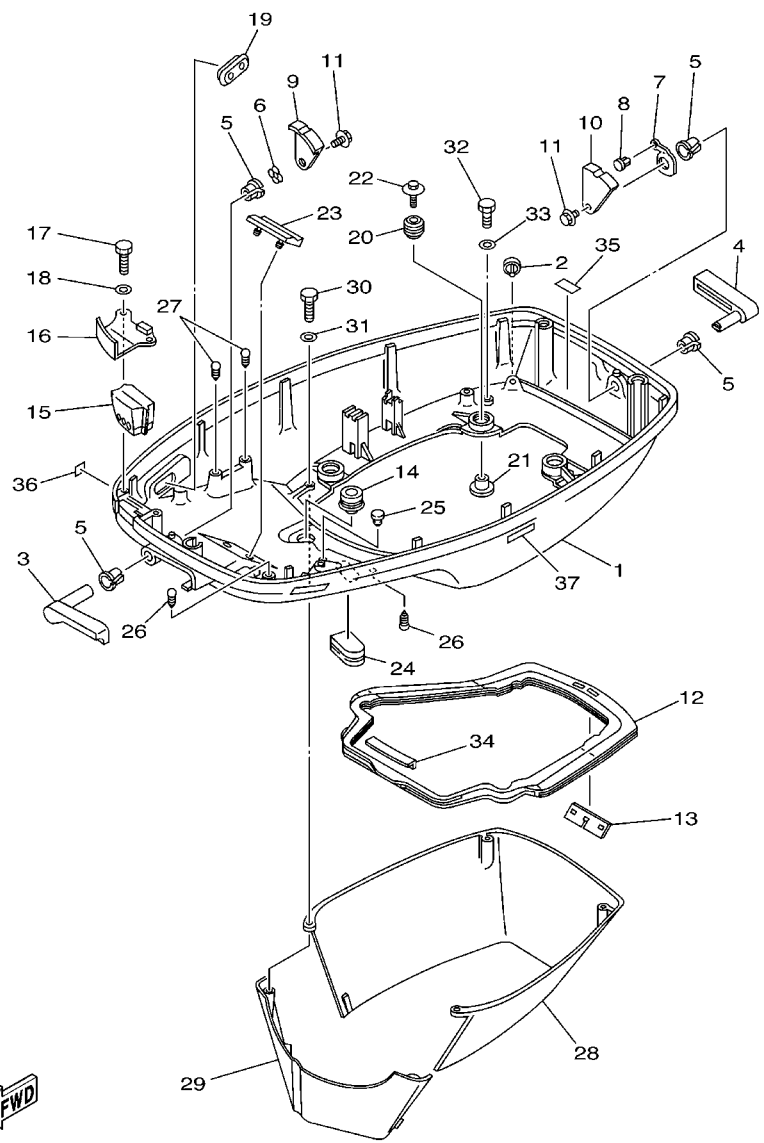

69D1300-2100

REF. NO.	PART NO. CODIGO Nº	DESCRIPTION DESCRIPCION	MHD	WHD	WD	REMARKS OBSERVACIONES
25	703-82119-00	COVER, LEAD WIRE CUBIERTA DE CABLE CONDUCTOR	2	2	2	
26	90338-05M03	PLUG TAPON	2	2	2	
27	90338-05M03	PLUG TAPON	2		2	
28	6H3-42741-01-4D	APRON MANDIL	1	1	1	
29	6H3-42771-01-4D	APRON MANDIL	1	1	1	
30	97095-06025	BOLT PERNO	2	2	2	
31	92995-06600	WASHER ARANDELA	2	2	2	
32	97095-06020	BOLT PERNO	2	2	2	
33	92995-06600	WASHER ARANDELA	2	2	2	
34	6H3-42718-00	RUBBER, SEAL 3 GOMA	1	1	1	
35	6G5-42791-00	MARK 1 MARCA 1	1	1	1	
	6G5-42791-10	MARK 1 MARCA 1	1	1	1	FOR CAR, CHN, TWN
36	6A1-28176-00	LABEL, CAUTION ETIQUETA DE PRECAUCION	1			FOR CAR
37	6E3-8257H-00	PLATE, MARK PLACA DE MARCA	1			FOR CAR

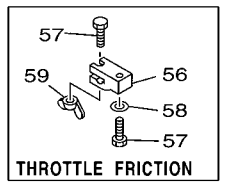
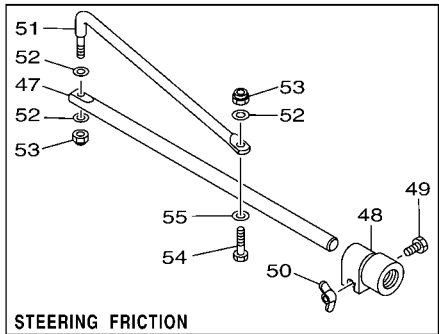
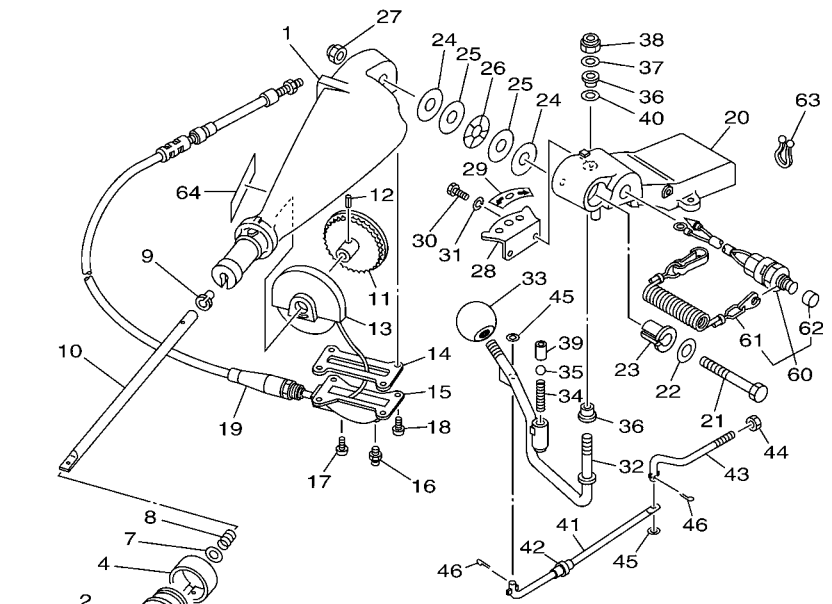

FWD
69D3700-C110

FIG. 16 STEERING

DIRECCION

REF. NO.	PART NO. CODIGO Nº	DESCRIPTION DESCRIPCION	MHD	WHHD	WD	REMARKS OBSERVACIONES
1	663-42111-02-4D	HANDLE, STEERING MANIJA DE DIRECCION	1	1		
	692-42111-21-4D	HANDLE, STEERING MANIJA DE DIRECCION	1	1		PULL TO OPEN TYPE PULL TO OPEN TYPE
2	664-42119-00	GRIP, STEERING HANDLE MANGO, MANIJA DE DIRRECCION	1	1		
3	6F6-42177-A0	RUBBER, HANDLE HULE DE MANIJA	1	1		
4	6K5-42137-00	INDICATOR, THROTTLE INDICADOR ACELERADOR	1	1		
5	90269-02M09	RIVET REMACHE	1	1		
6	90149-05M13	SCREW TORNILLO DE REGLAJE	1	1		
7	92903-10600	WASHER, PLATE RONDANA SENCILLA	1	1		
8	90501-23215	SPRING, COMPRESSION RESORTE DE COMPRESION	1	1		
9	90386-08032	BUSH BUJE	1	1		
10	663-42115-00	SHAFT, STEERING HANDLE EJE MANIJA DE DIRECCION	1	1		
	692-42115-00	SHAFT, STEERING HANDLE EJE MANIJA DE DIRECCION	1	1		PULL TO OPEN TYPE PULL TO OPEN TYPE
11	663-42138-00	LEVER, THROTTLE PLANCA DE ACELERACION	1	1		
12	90254-03003	PIN, SPRING PASADOR DE TIPO A RESORTE	1	1		
13	663-42135-01	HOUSING, THROTTLE LEVER CAJA PALANCA ACELERADOR	1	1		
14	663-42133-01	GASKET EMPAQUE	1	1		
15	663-42134-03-94	COVER, THROTTLE LEVER CUBIERTA PALANCA ACELERADOR	1	1		
16	93700-06M03	NIPPLE, GREASE BOQUILLA DE ENGRASAR	1	1		
17	97885-06008	SCREW, PAN HEAD TORNILLO A MUESCA	1	1		
18	97885-05012	SCREW, PAN HEAD TORNILLO A MUESCA	4	4		
19	692-26301-03	THROTTLE CABLE ASSY CABLE DE ACELERADOR COMPLETO	1	1		
20	692-42121-02-4D	BRACKET SOPORTE	1	1		
21	90101-12M06	BOLT TORNILLO	1	1		
22	92990-12200	WASHER, PLAIN ARANDELA PLANA	1	1		
23	90386-12089	BUSH BUJE	1	1		
24	90202-12092	WASHER, PLATE ARANDELA DE PLANA	2	2		
25	90201-12537	WASHER, PLATE ARANDELA PLANA	2	2		

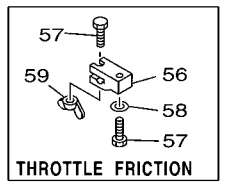
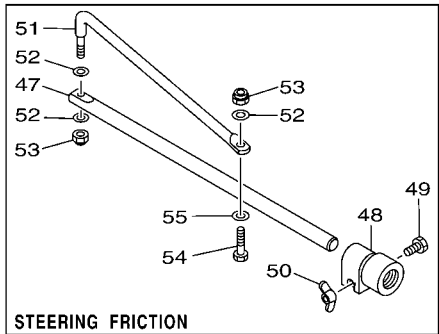
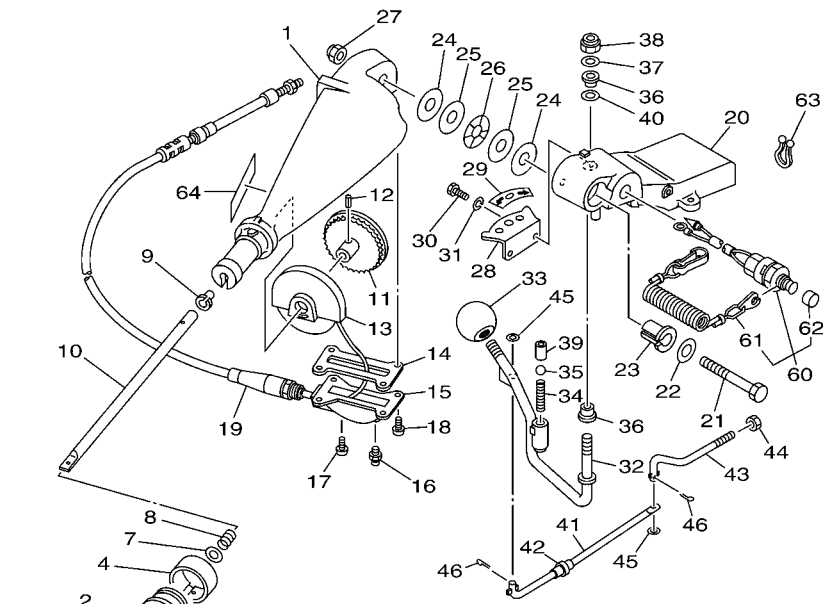

FWD
69D3700-C110

FIG. 16 STEERING

DIRECCION

REF. NO.	PART NO. CODIGO Nº	DESCRIPTION DESCRIPCION	MHD	WHD	WD	REMARKS OBSERVACIONES
26	90206-12054	WASHER, WAVE ARANDELA ONDULADA	1	1		
27	90185-12058	NUT, SELF-LOCKING TUERCA AUTOBLOCANTE	1	1		
28	697-44113-00	CAM PLATE, HANDLE PLACA DE LA LEVA DEL MANGO	1	1		
29	6K5-44191-00	INDICATOR, SHIFT INDICADOR DE CAMBIOS	1	1		
30	97013-06016	BOLT PERNO	2	2		
31	92903-06100	WASHER, SPRING RONDANA SENCILLA	2	2		
32	692-44159-01	HANDLE, GEAR SHIFT MANIJA DE CAMBIO DE MARCHAS	1	1		
33	663-44173-00	LEVER, SHIFT CONTROL PALANCA CONTROL CAMBIOS	1	1		
34	90501-16M17	SPRING, COMPRESSION RESORTE DE COMPRESION	1	1		
35	93515-32M01	BALL ESFERA	1	1		
36	90386-10009	BUSH BUJE	2	2		
37	90201-10120	WASHER, PLATE ARANDELA PLANA	1	1		
38	90185-10051	NUT, SELF-LOCKING TUERCA AUTOBLOCANTE	1	1		
39	90387-12M30	COLLAR ESPACIADOR	1	1		
40	90201-12M34	WASHER, PLATE ARANDELA PLANA	1	1		
41	6H3-42191-01	ROD 1 VARILLA 1	1	1		
42	90386-06088	BUSH BUJE	1	1		
43	6H3-42192-00	ROD 2 VARILLA 2	1	1		
44	700-48339-00	NUT, CABLE END TUERCA TERMINAL	1	1		
45	92990-06600	WASHER, PLATE ARANDELA PLANA	2	2		
46	91490-25012	PIN, COTTER CHAVETA	2	2		
47	663-42518-00	SHAFT, FRICTION EJE FRICCION	1	1		FOR OMN
48	67G-42528-00	PLATE, FRICTION PIEZA DE FRICCION	1	1		FOR OMN
49	97080-06035	BOLT PERNO	1	1		FOR OMN
50	90175-06003	NUT, WING TUERCA MARIPOSA	1	1		FOR OMN
51	69D-42515-00	ROD, STEERING LINK VARILLA ESLABON DIRECCION	1	1		FOR OMN
52	92990-08600	WASHER, PLATE ARANDELA PLANA	3	3		FOR OMN

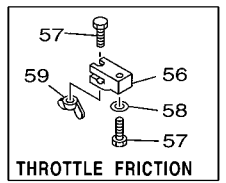
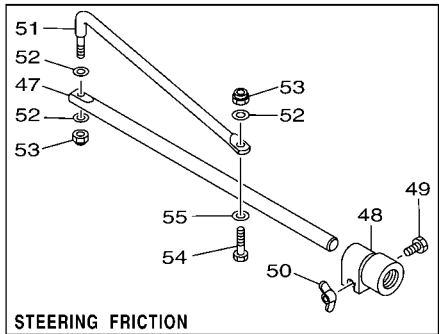
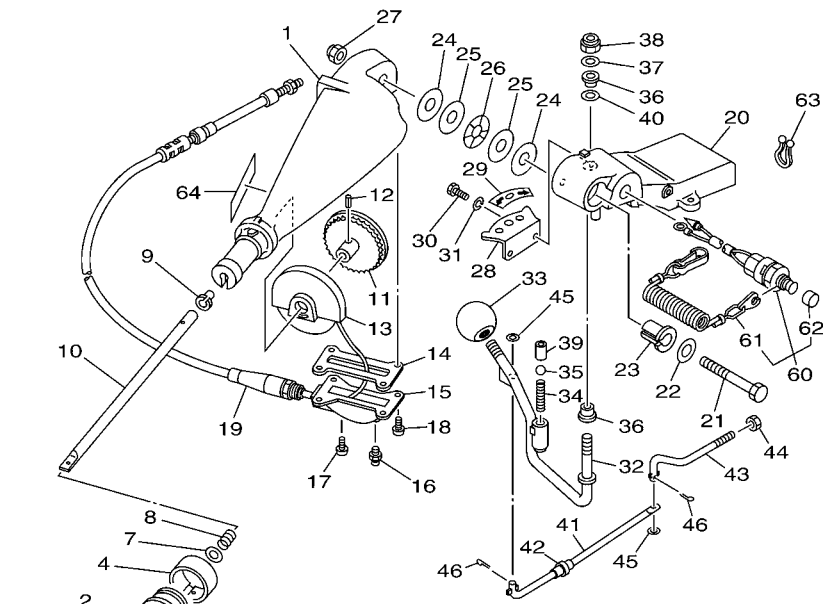

69D3700-C110

FIG. 16 STEERING

DIRECCION

REF. NO.	PART NO. CODIGO N°	DESCRIPTION DESCRIPCION	MHD	WHD	WD	REMARKS OBSERVACIONES
53	90185-08057	NUT, SELF-LOCKING TUERCA AUTOBLOCANTE	2	2		FOR OMN FOR OMN
54	97095-08030	BOLT PERNO	1	1		FOR OMN FOR OMN
55	92995-08600	WASHER ARANDELA	1	1		FOR OMN FOR OMN
56	663-42126-01	FRICION, STEERING HANDLE GRIP FRICCION DE MANGO DIRECCION	1	1		
57	90101-06M27	BOLT TORNILLO	2	2		
58	92990-06600	WASHER, PLATE ARANDELA PLANA	1	1		
59	90175-06003	NUT, WING TUERCA MARIPOSA	1	1		
60	6K5-82575-03	ENGINE STOP SWITCH ASSY INTERRUPTOR DE PARADA COMPL	1			
61	682-82556-00	.LANYARD, STOP SWITCH .RETENER	1			
62	689-8257Y-00	.CAP .CASQUILLO	1			
63	90464-08M07	CLAMP BRIDA	2			
64	6E0-83627-41	LABEL, CAUTION 7 ETIQUETA DE PRECAUCION 7	1	1		

FWD
6K50100-4160

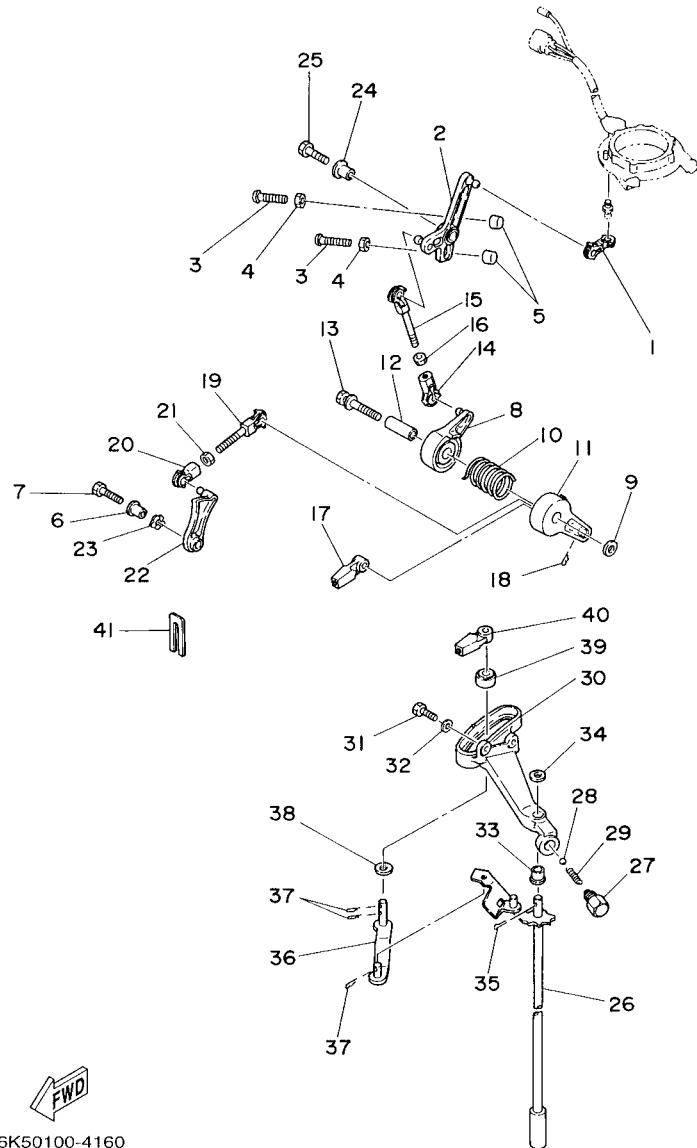
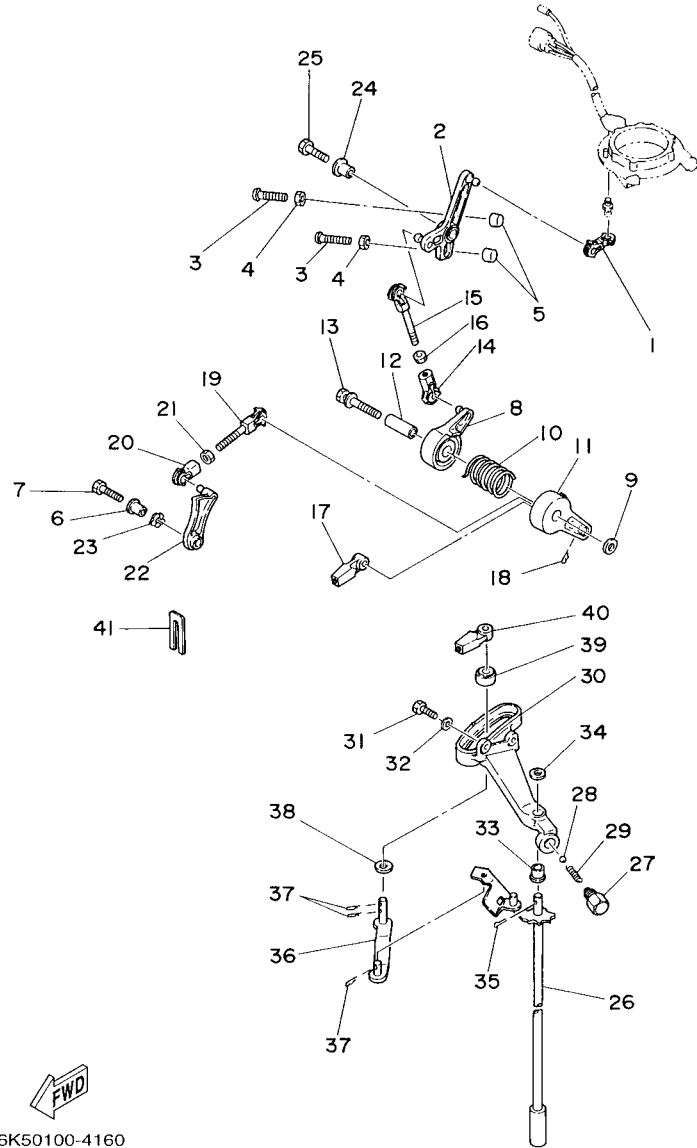

FIG. 17 CONTROL

CONTROL

REF. NO.	PART NO. CODIGO Nº	DESCRIPTION DESCRIPCION	MHD	WHD	WD	REMARKS OBSERVACIONES
1	6H3-41238-00	JOINT, LINK CONECTOR	1	1	1	
2	6H3-41631-00	LEVER, MAGNETO CONTROL PALANCA DE CONTROL DE MAGNETO	1	1	1	
3	90157-06M13	SCREW, PAN HEAD TORNILLO CABEZA CONICA PLANA	2	2	2	
4	95380-06600	NUT, HEXAGON TUERCA	2	2	2	
5	688-44194-00	CAP TAPA	2	2	2	
6	90387-06M60	COLLAR ESPACIADOR	1	1	1	
7	97095-06025	BOLT PERNO	1	1	1	
8	6H3-41632-00	LEVER, MAGNETO CONTROL PALANCA DE CONTROL DE MAGNETO	1	1	1	
9	90201-06M31	WASHER, PLATE ARANDELA PLANA	1	1	1	
10	90508-29M19	SPRING, TORSION RESORTE DE TORSION	1	1	1	
11	6H3-41633-00	LEVER, MAGNETO CONTROL PALANCA DE CONTROL DE MAGNETO	1	1	1	
12	90387-06M59	COLLAR ESPACIADOR	1	1	1	
13	90119-06M91	BOLT, WITH WASHER TORNILLO CON ARANDELA	1	1	1	
14	662-41237-01	JOINT, LINK CONECTOR	1	1	1	
15	679-41636-00	ROD, MAGNETO CONTROL VARILLA DE CONTROL MAGNETO	1	1	1	
16	95380-05600	NUT TUERCA	1	1	1	
17	663-48344-00	CABLE END, REMOTE CONTROL BASE CONTROL	1	1	1	
18	90468-18008	CLIP PRESILLA	1	1	1	
19	682-41237-50	JOINT, LINK CONECTOR	1	1	1	
20	662-41237-01	JOINT, LINK CONECTOR	1	1	1	
21	95380-05600	NUT TUERCA	1	1	1	
22	6H3-41213-01	CAM, ACCEL. LEVA ACELERADOR	1	1	1	
23	90206-10M04	WASHER, WAVE ARANDELA ONDULADA	1	1	1	
24	90387-06M60	COLLAR ESPACIADOR	1	1	1	
25	97095-06025	BOLT PERNO	1	1	1	
26	6K5-44120-01	HANDLE GEAR SHIFT ASSY MANIJA DE CAMBIO COMPL	1			S (17.7") S (17.7")
	6K5-44120-11	HANDLE GEAR SHIFT ASSY MANIJA DE CAMBIO COMPL	1	1	1	L (22.5") L (22.5")



FWD
6K50100-4160

FIG. 17 CONTROL

CONTROL

REF. NO.	PART NO. CODIGO Nº	DESCRIPTION DESCRIPCION	MHD	WHD	WD	REMARKS OBSERVACIONES
26	69D-44120-20	HANDLE GEAR SHIFT ASSY MANIJA DE CAMBIO COMPL	1			X (25.5") X (25.5")
27	648-42715-00	BUSHING BUJE	1	1	1	
28	93501-04M02	BALL BOLA	1	1	1	
29	90501-12082	SPRING, COMPRESSION RESORTE DE COMPRESION	1	1	1	
30	6H3-44117-00-94	BRACKET SOPORTE	1	1	1	
	6J2-44117-01-94	BRACKET SOPORTE	1	1		FOR OMN FOR OMN
31	97013-06020	BOLT PERNO	2	2	2	
32	92903-06600	WASHER, PLATE RONDANA SENCILLA	2	2	2	
33	90386-07M58	BUSH BUJE	1	1	1	
34	92990-08200	WASHER, PLAIN ARANDELA PLANA	1	1	1	
35	91490-20012	PIN, COTTER CHAVETA	1	1	1	
36	6H3-44121-01	LEVER, SHIFT ROD PALANCA VARILLA CAMBIOS	1	1	1	
37	90468-18008	CLIP PRESILLA	3	3	3	
38	90202-07M07	WASHER, PLATE ARANDELA DE PLANA	1	1	1	
39	688-44122-00	BUSHING, SHIFT ROD LEVER BUJE PALANCA VARILLA DE CAMBIO	1	1	1	
40	663-48344-00	CABLE END, REMOTE CONTROL BASE CONTROL	1	1	1	
41	6H3-48538-00	CLAMP, CABLE 1 GRAMPA DE CABLE	1	1	1	

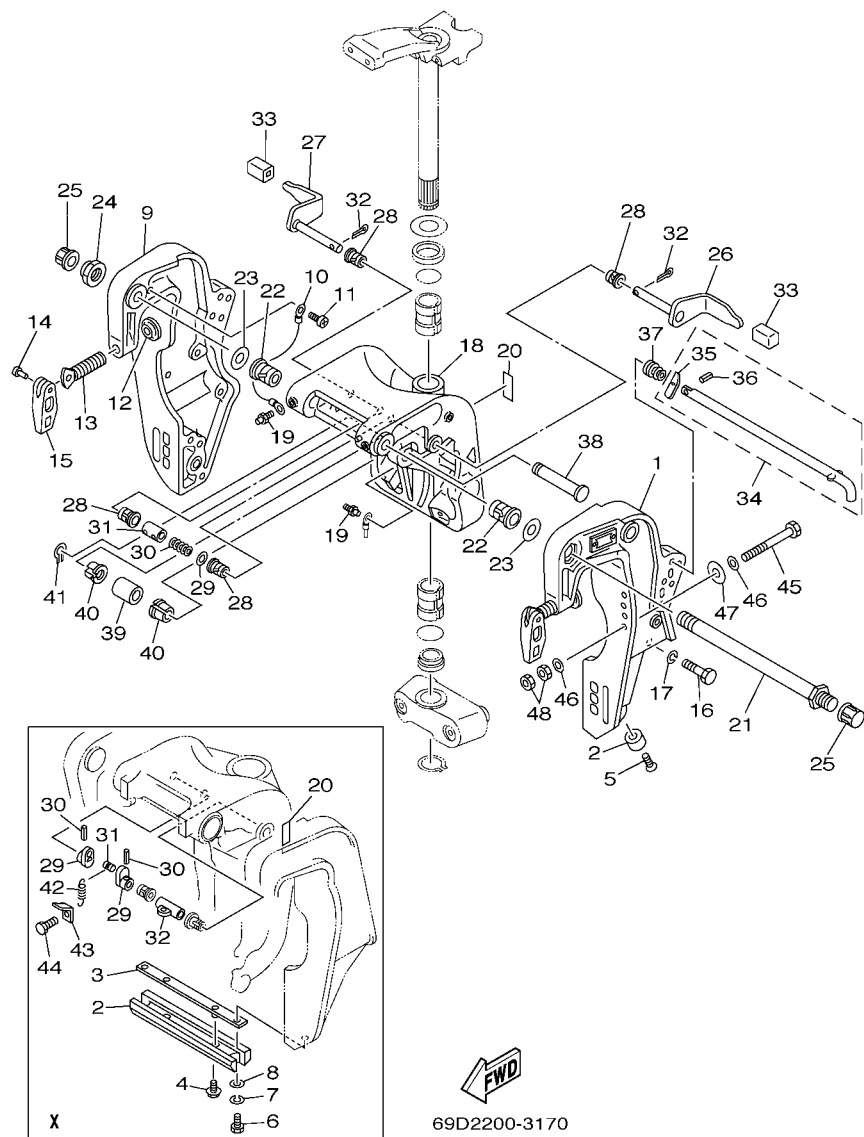

FIG. 18 BRACKET 1

SOPORTE 1

REF. NO.	PART NO. CODIGO Nº	DESCRIPTION DESCRIPCION	MHD	WHD	WD	REMARKS OBSERVACIONES
1	697-43111-05-4D	BRACKET, CLAMP 1 SOPORTE DE LA ABRAZADERA 1	1			S (17.7") S (17.7")
	688-43111-13-4D	BRACKET, CLAMP 1 SOPORTE DE LA ABRAZADERA 1	1			X (25.5") X (25.5")
2	663-45251-00	ANODE CATODE	2			S (17.7") S (17.7")
	6H1-45251-03	ANODE CATODE	1			X (25.5") X (25.5")
3	6H1-44526-00	PLATE PLACA 1	1			X (25.5") X (25.5")
4	90119-06M29	BOLT, WITH WASHER TORNILLO CON ARANDELA	2			X (25.5") X (25.5")
5	90152-06M01	SCREW, COUNTERSUNK TORNILLO EMBUTIDO	2			S (17.7") S (17.7")
6	97095-06016	BOLT PERNO	2			X (25.5") X (25.5")
7	92995-06100	WASHER, SPRING ARANDELA	2			X (25.5") X (25.5")
8	92995-06600	WASHER ARANDELA	2			X (25.5") X (25.5")
9	697-43112-03-4D	BRACKET, CLAMP 2 SOPORTE DE LA ABRAZADERA 2	1			S (17.7") S (17.7")
	688-43112-12-4D	BRACKET, CLAMP 2 SOPORTE DE LA ABRAZADERA 2	1			X (25.5") X (25.5")
10	6E5-82148-00	WIRE, LEAD 4 CABLE CONDUCTOR 4	1			
11	97880-06012	SCREW, PAN HEAD TORNILLO DE CABEZA CON PLANA	1			
12	648-43114-01	PAD, TRANSOM CLAMP ARANDELA DE ABRAZADERA	2			
13	663-43116-01	SCREW, TRANSOM CLAMP TORNILLO DE ABRAZADERA	2			
14	90243-04007	PIN PASADOR	2			
15	663-43118-01-4D	HANDLE, TRANSOM CLAMP MANIJA DE LA ABRAZADERA DEL ES	2			
16	97095-10045	BOLT PERNO	6			
17	92995-10100	WASHER ARANDELA	6			
18	697-43311-03-4D	BRACKET, SWIVEL 1 SOPORTE GIRATORIO 1	1			S (17.7") S (17.7")
	6H1-43311-02-4D	BRACKET, SWIVEL 1 SOPORTE GIRATORIO 1	1			X (25.5") X (25.5")
19	93700-06M03	NIPPLE, GREASE BOQUILLA DE ENGRASAR	3			
20	63D-43691-00	INDICATOR, TILT INDICADOR	1			
21	688-43131-03	BOLT, CLAMP BRACKET TORNILLO DE ABRAZADERA DEL SOP	1			
22	90386-22M15	BUSH BUJE	2			
23	90201-22M67	WASHER, PLATE ARANDELA PLANA	2			

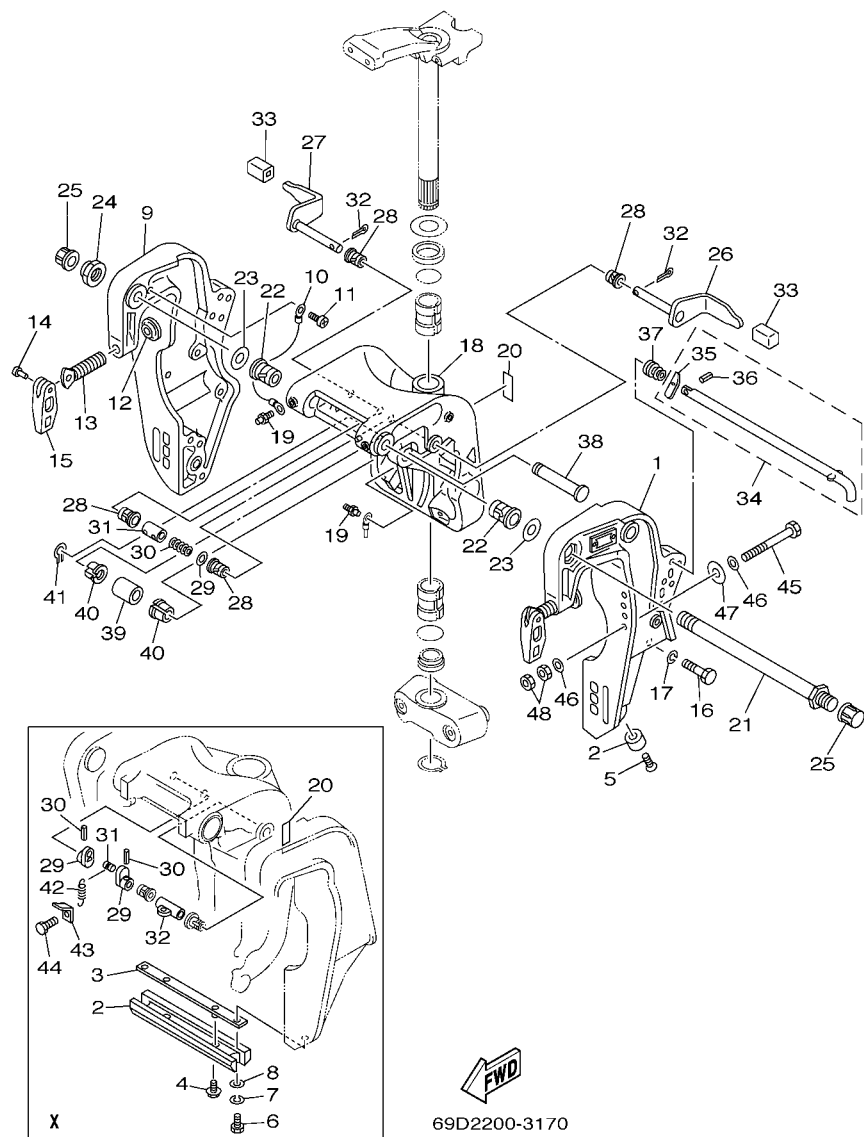

FIG. 18 BRACKET 1

SOPORTE 1

REF. NO.	PART NO. CODIGO Nº	DESCRIPTION DESCRIPCION	MHD	WHD	WD	REMARKS OBSERVACIONES
24	90185-22043	NUT, SELF-LOCKING TUERCA AUTOBLOCANTE	1			
25	6G5-43145-01	CAP, CLAMP BRACKET TAPA	2			
26	688-43181-04	LEVER, TILT STOP PALANCA TOPE INCLINACION	1			S (17.7") S (17.7")
	688-43181-10	LEVER, TILT STOP PALANCA TOPE INCLINACION	1			X (25.5") X (25.5")
27	688-43185-04	LEVER, TILT STOP PALANCA TOPE INCLINACION	1			S (17.7") S (17.7")
	688-43185-10	LEVER, TILT STOP PALANCA TOPE INCLINACION	1			X (25.5") X (25.5")
28	90386-10M16	BUSH BUJE	4			
29	92990-10600	WASHER, PLATE ARANDELA PLANA	1			S (17.7") S (17.7")
	6G5-43148-00	COLLAR, DISTANCE COLLAR	2			X (25.5") X (25.5")
30	90501-10M21	SPRING, COMPRESSION RESORTE DE COMPRESION	1			S (17.7") S (17.7")
	91690-30020	PIN, SPRING PASADOR DE RESORTE	2			X (25.5") X (25.5")
31	90387-10M38	COLLAR ESPACIADOR	1			S (17.7") S (17.7")
	90249-06M19	PIN PASADOR	1			X (25.5") X (25.5")
32	91490-30025	PIN, COTTER CHAVETA	2			S (17.7") S (17.7")
	90387-10M02	COLLAR ESPACIADOR	1			X (25.5") X (25.5")
33	663-43318-00	COVER CUBIERTA	2			
34	697-43160-00	TILT ROD ASSY VARILLA DE BASCULACION COMPL.	1			S (17.7") S (17.7")
	688-43160-01	TILT ROD ASSY VARILLA DE BASCULACION COMPL.	1			X (25.5") X (25.5")
35	688-43165-00	.PLATE, TILT LOCK .PLACA DE TOPE, VARILLA SEGUR	1			
36	91690-30012	.PIN, SPRING .PASADOR DE RESORTE	1			
37	90502-20M03	SPRING, CONICAL RESORTE CONICO	1			S (17.7") S (17.7")
	90502-16M02	SPRING, CONICAL RESORTE CONICO	1			X (25.5") X (25.5")
38	6E5-43126-02	PIN, UPPER SHOCK MOUNT PASADOR DE AMORTIGUADOR SUPER	1			
39	90386-18M21	BUSH BUJE	1			
40	90386-18M35	BUSH BUJE	2			
41	93410-18M02	CIRCLIP SEGURO	1			
42	90506-14M24	SPRING, TENSION RESORTE DE TENSION	1			X (25.5") X (25.5")

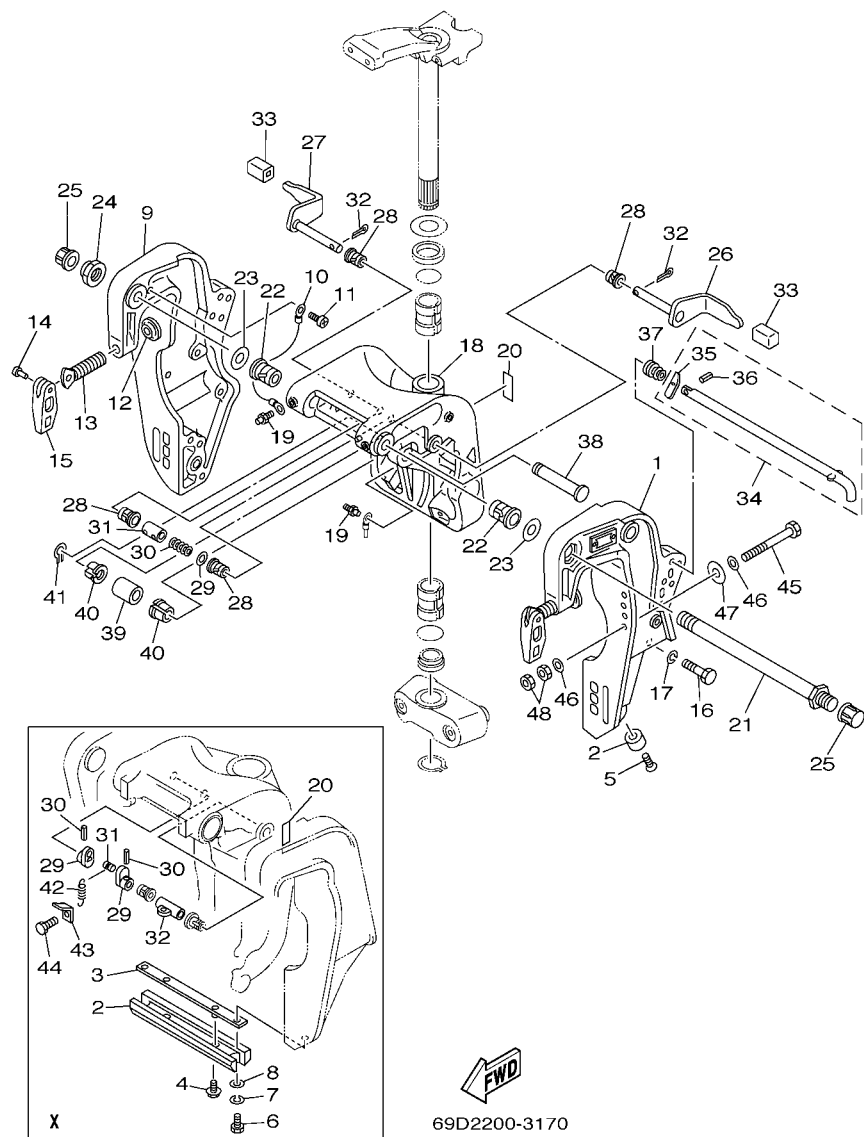

FIG. 18 BRACKET 1

SOPORTE 1

REF. NO.	PART NO. CODIGO Nº	DESCRIPTION DESCRIPCION	MHD	WHD	WD	REMARKS OBSERVACIONES
43	6G5-43144-00	HOOK, SPRING GANCHO	1			X (25.5") X (25.5")
44	97095-06010	BOLT PERNO	1			X (25.5") X (25.5")
45	90101-12M65	BOLT TORNILLO	4			
46	92995-12200	WASHER ARANDELA	8			
47	90201-12426	WASHER, PLATE ARANDELA PLANA	4			
48	95380-12600	NUT TUERCA	8			

FIG. 19 BRACKET 2

SOPORTE 2

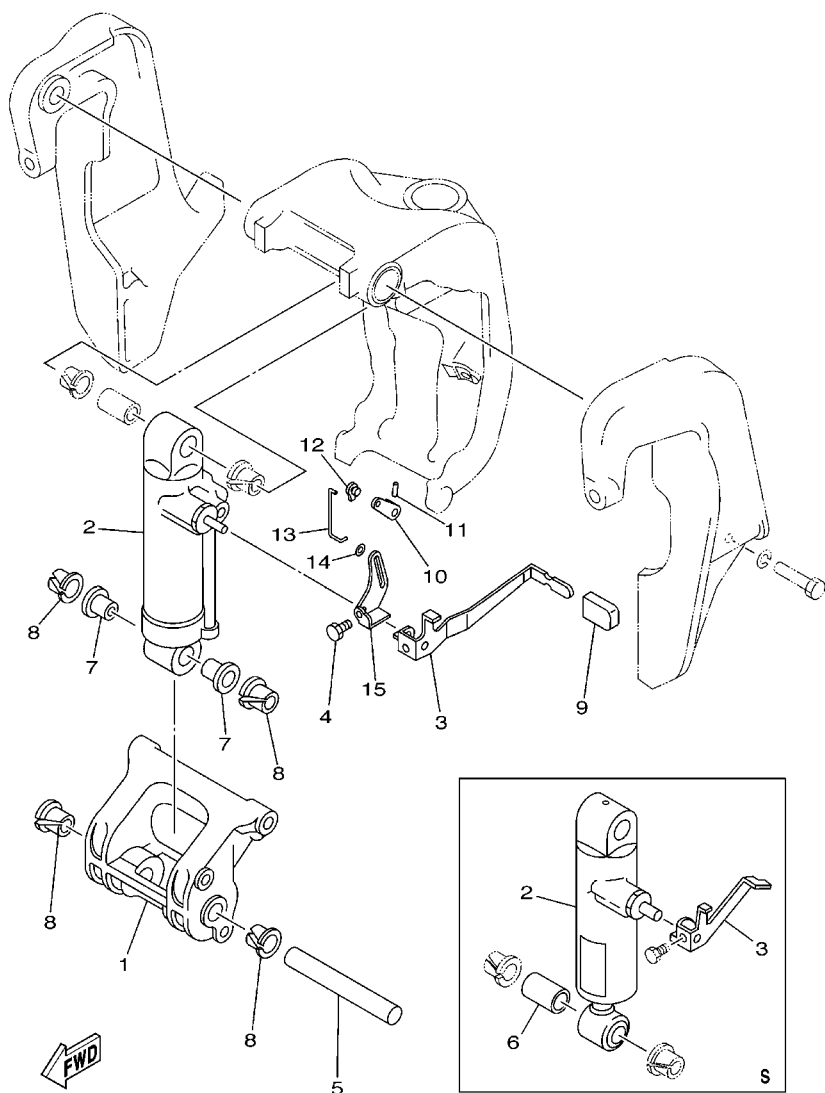

6961200-2160

REF. NO.	PART NO. CODIGO Nº	DESCRIPTION DESCRIPCION	MHD	WHD	WD	REMARKS OBSERVACIONES
1	697-43128-01-4D	SPACER, CLAMP BRACKET ESPACIADOR ABRAZADERA SOPORTE	1			S (17.7") S (17.7")
	688-43128-01-4D	SPACER, CLAMP BRACKET ESPACIADOR ABRAZADERA SOPORTE	1			X (25.5") X (25.5")
2	697-43170-03-4D	SHOCK ABSORBER ASSY AMORTIGUADOR COMPL.	1			S (17.7") S (17.7")
	688-43170-04-4D	SHOCK ABSORBER ASSY AMORTIGUADOR COMPL.	1			X (25.5") X (25.5")
3	688-43631-00	LEVER, TILT PALANCA DE INCLINACION	1			S (17.7") S (17.7")
	688-43631-10	LEVER, TILT PALANCA DE INCLINACION	1			X (25.5") X (25.5")
4	97080-06010	BOLT PERNO	1			
5	688-43124-02	PIN, LOWER SHOCK MOUNT PASADOR DE AMORTIGUADOR INFERI	1			
6	90386-18M21	BUSH BUJE	1			S (17.7") S (17.7")
7	90386-18M63	BUSH BUJE	2			X (25.5") X (25.5")
8	90386-18M35	BUSH BUJE	4			
9	682-43318-01	COVER CUBIERTA	1			X (25.5") X (25.5")
10	688-43186-00	LEVER PALANCA	1			X (25.5") X (25.5")
11	91690-30020	PIN, SPRING PASADOR DE RESORTE	1			X (25.5") X (25.5")
12	6J8-41262-00	JOINT, CHOKE LEVER CONECTOR DE AHOGADOR	1			X (25.5") X (25.5")
13	688-43616-00	ROD, TILT LOCK VARILLA SEGURO DE INCLINACION	1			X (25.5") X (25.5")
14	90202-03M51	WASHER, PLATE ARANDELA DE PLANA	1			X (25.5") X (25.5")
15	688-43651-00	LEVER, REVERSE LOCK 1 PALANCA SEGURO DE RESERVA	1			X (25.5") X (25.5")

FIG. 20 BRACKET 3

SOPORTE 3

FOR LONG

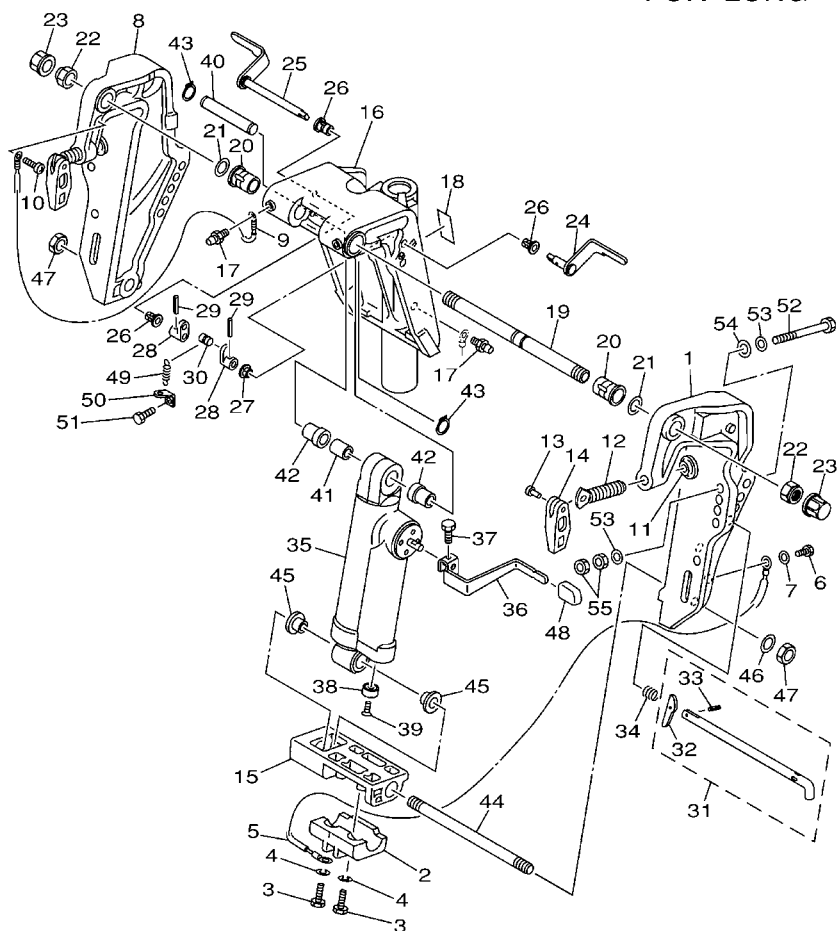

69D0200-1180

REF. NO.	PART NO. CODIGO Nº	DESCRIPTION DESCRIPCION	MHD	WHD	WD	REMARKS OBSERVACIONES
1	63D-43111-01-4D	BRACKET, CLAMP 1 SOPORTE DE LA ABRAZADERA 1	1	1	1	
2	63D-45251-00	ANODE CATODE	1	1	1	
3	97095-06025	BOLT PERNO	2	2	2	
4	92995-06100	WASHER, SPRING ARANDELA	2	2	2	
5	6H1-82148-00	WIRE, LEAD 4 CABLE CONDUCTOR 4	1	1	1	
6	97095-06010	BOLT PERNO	1	1	1	
7	92995-06600	WASHER ARANDELA	1	1	1	
8	63D-43112-01-4D	BRACKET, CLAMP 2 SOPORTE DE LA ABRAZADERA 2	1	1	1	
9	63D-82148-00	WIRE, LEAD 4 CABLE CONDUCTOR 4	1	1	1	
10	97885-06008	SCREW, PAN HEAD TORNILLO A MUESCA	1	1	1	
11	648-43114-01	PAD, TRANSOM CLAMP ARANDELA DE ABRAZADERA	2	2	2	
12	663-43116-01	SCREW, TRANSOM CLAMP TORNILLO DE ABRAZADERA	2	2	2	
13	90243-04007	PIN PASADOR	2	2	2	
14	663-43118-01-4D	HANDLE, TRANSOM CLAMP MANIJA DE LA ABRAZADERA DEL ES	2	2	2	
15	63D-43128-01-4D	SPACER, CLAMP BRACKET ESPACIADOR ABRAZADERA SOPORTE	1	1	1	
16	69D-43311-11-4D	BRACKET, SWIVEL 1 SOPORTE GIRATORIO 1	1	1	1	
17	93700-06M03	NIPPLE, GREASE BOQUILLA DE ENGRASAR	3	3	3	
18	63D-43691-00	INDICATOR, TILT INDICADOR	1	1	1	
19	63D-43131-01	BOLT, CLAMP BRACKET TORNILLO DE ABRAZADERA DEL SOP	1	1	1	
20	90386-22M15	BUSH BUJE	2	2	2	
21	90201-22M03	WASHER, PLATE ARANDELA PLANA	2	2	2	
22	90185-22M11	NUT, SELF-LOCKING TUERCA AUTOBLOCANTE	2	2	2	
23	6G5-43145-01	CAP, CLAMP BRACKET TAPA	2	2	2	
24	6H5-43181-03	LEVER, TILT STOP PALANCA TOPE INCLINACION	1	1	1	
25	6H5-43185-03	LEVER, TILT STOP PALANCA TOPE INCLINACION	1	1	1	
26	90386-10M16	BUSH BUJE	3	3	3	
27	90386-10025	BUSH BUJE	1	1	1	

FIG. 20 BRACKET 3

SOPORTE 3

FOR LONG

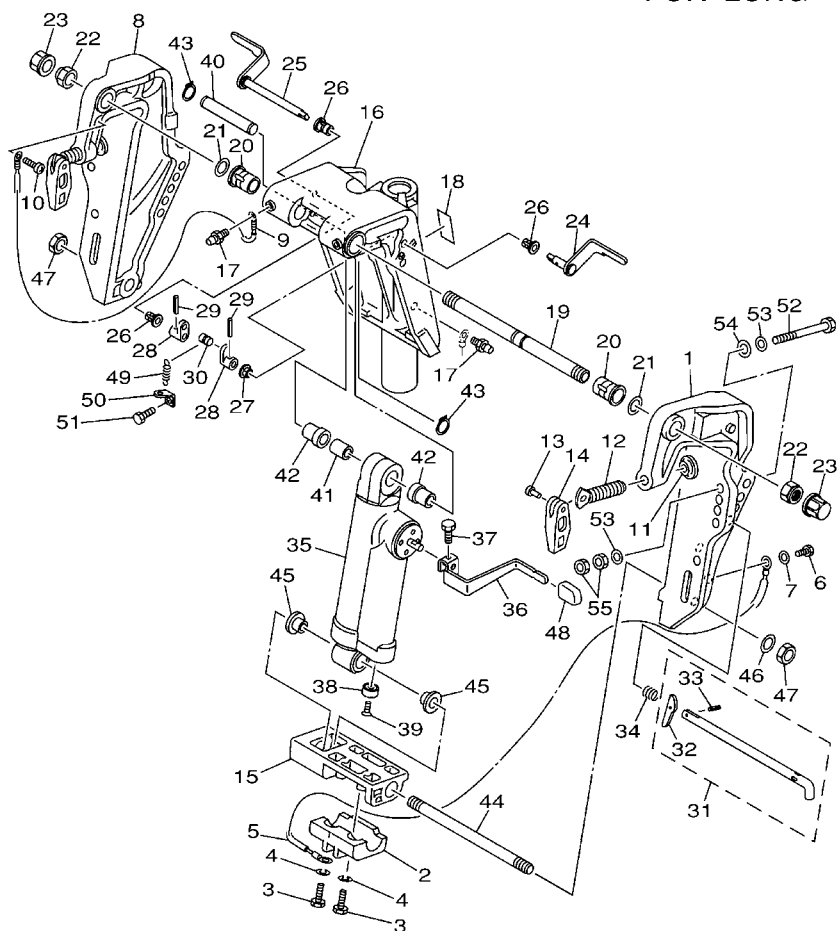

69D0200-1180

REF. NO.	PART NO. CODIGO Nº	DESCRIPTION DESCRIPCION	MHD	WHD	WD	REMARKS OBSERVACIONES
28	6G5-43148-00	COLLAR, DISTANCE COLLAR	2	2	2	
29	91690-30020	PIN, SPRING PASADOR DE RESORTE	2	2	2	
30	90249-06M19	PIN PASADOR	1	1	1	
31	688-43160-01	TILT ROD ASSY VARILLA DE BASCULACION COMPL.	1	1	1	
32	688-43165-00	.PLATE, TILT LOCK .PLACA DE TOPE, VARILLA SEGUR	1	1	1	
33	91690-30012	.PIN, SPRING .PASADOR DE RESORTE	1	1	1	
34	90502-16M02	SPRING, CONICAL RESORTE CONICO	1	1	1	
35	69D-43170-10-4D	SHOCK ABSORBER ASSY AMORTIGUADOR COMPL.	1	1	1	
36	69D-43631-00	LEVER, TILT PALANCA DE INCLINACION	1	1	1	
37	97095-06010	BOLT PERNO	1	1	1	
38	663-45251-00	ANODE CATODE	1	1	1	
39	98680-06525	SCREW, OVAL HEAD TORNILLO CABEZA OVALADA	1	1	1	
40	69D-43126-00	PIN, UPPER SHOCK MOUNT PASADOR DE AMORTIGUADOR SUPER	1	1	1	
41	90387-16003	COLLAR ESPACIADOR	1	1	1	
42	90387-16004	COLLAR ESPACIADOR	2	2	2	
43	93410-16006	CIRCLIP SEGURO	2	2	2	
44	90116-18M52	BOLT, STUD ESPARRAGO	1	1	1	
45	90386-18M44	BUSH BUJE	2	2	2	
46	92995-18600	WASHER ARANDELA	1	1	1	
47	90170-18M10	NUT TUERCA	2	2	2	
48	682-43318-01	COVER CUBIERTA	1	1	1	
49	90506-14M24	SPRING, TENSION RESORTE DE TENSION	1	1	1	
50	6G5-43144-00	HOOK, SPRING GANCHO	1	1	1	
51	97095-06010	BOLT PERNO	1	1	1	
52	90101-12M65	BOLT TORNILLO	4	4	4	
53	92995-12200	WASHER ARANDELA	8	8	8	
54	90201-12426	WASHER, PLATE ARANDELA PLANA	4	4	4	

FIG. 20 BRACKET 3

SOPORTE 3

REF. NO.	PART NO. CODIGO Nº	DESCRIPTION DESCRIPCION	MHD	WHD	WD	REMARKS OBSERVACIONES
55	95380-12600	NUT TUERCA	8	8	8	

FOR LONG

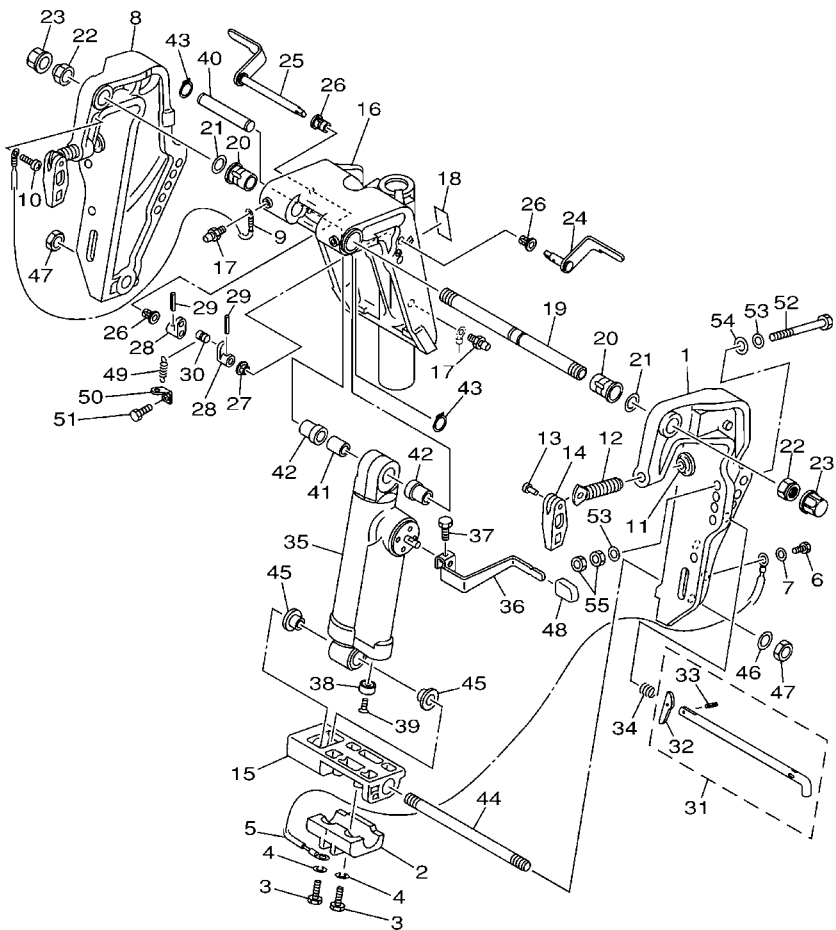

69D0200-1180

F3

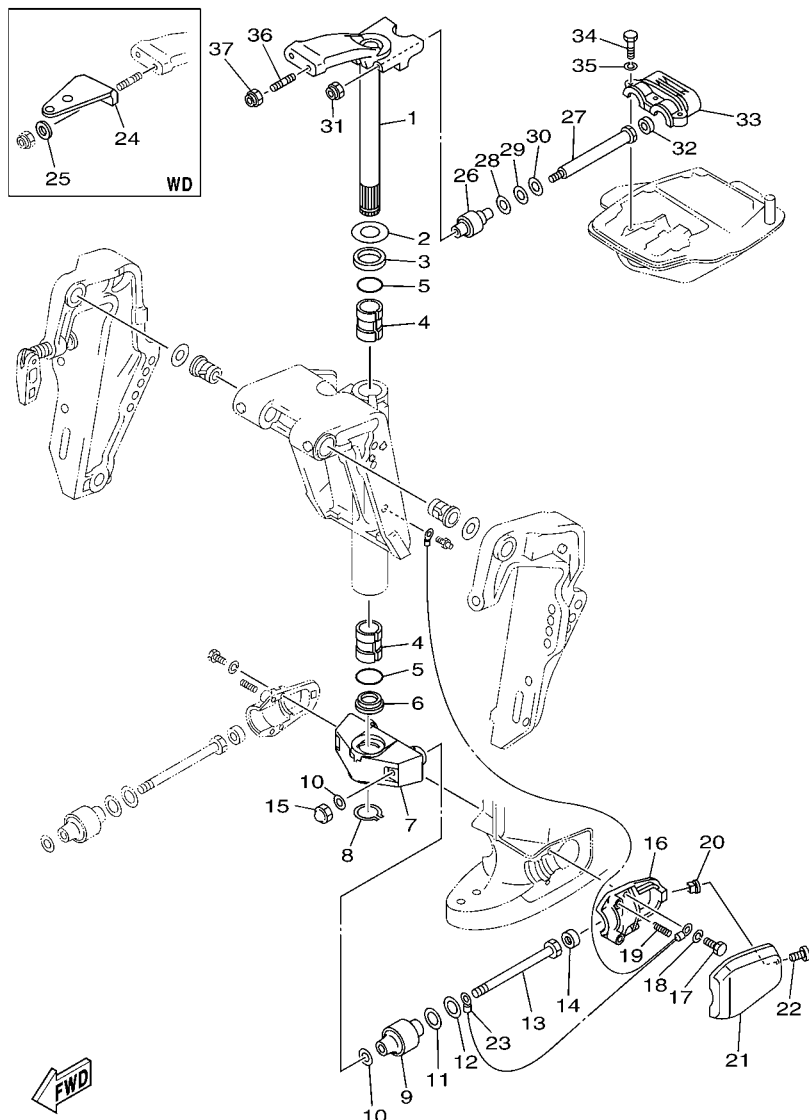

69D5200-E210

FIG. 21 BRACKET 4

SOPORTE 4

REF. NO.	PART NO. CODIGO Nº	DESCRIPTION DESCRIPCION	MHD	WHD	WD	REMARKS OBSERVACIONES
1	6H3-42510-03-4D	STEERING BRACKET ASSY SOPORTE DIRECCION COMPL.	1			S(17.7") S(17.7")
	69D-42510-11-4D	STEERING BRACKET ASSY SOPORTE DIRECCION COMPL.	1	1	1	L(22.5"),X(25.5") L(22.5"),X(25.5")
2	90201-30M00	WASHER, PLATE ARANDELA PLANA	1	1	1	
3	90386-30M78	BUSH BUJE	1	1	1	
4	90386-30M77	BUSH BUJE	2	2	2	
5	93210-29M94	O-RING ANILLO O	2	2	2	
6	90386-30M60	BUSH BUJE	1	1	1	
7	6H3-44551-01-4D	HOUSING, LOWER MOUNT RUBBER CAJA AMORTIGUADOR INFERIOR HU	1			S(17.7") S(17.7")
	69D-44551-10-4D	HOUSING, LOWER MOUNT RUBBER CAJA AMORTIGUADOR INFERIOR HU	1	1	1	L(22.5"),X(25.5") L(22.5"),X(25.5")
8	93410-28M06	CIRCLIP SEGURO	1	1	1	
9	687-44555-00-94	MOUNT DAMPER, LOWER SIDE AMORTIGUADOR DE HULE LADO INFE	2	2	2	S(17.7"),L(22.5") S(17.7"),L(22.5")
	688-44555-00-94	MOUNT DAMPER, LOWER SIDE AMORTIGUADOR DE HULE LADO INFE	2			X(25.5") X(25.5")
10	90201-12M16	WASHER, PLATE ARANDELA PLANA	4	4	4	
11	90202-25M04	WASHER, PLATE ARANDELA DE PLANA	2	2	2	
12	90201-13M19	WASHER, PLATE ARANDELA PLANA	2	2	2	
13	90109-12M21	BOLT PERNO	2	2	2	
14	663-44575-00	DAMPER, LOWER MOUNT RUBBER AMORTIGUADOR INFERIOR	2	2	2	
15	95380-12800	NUT, CROWN TUERCA	2	2	2	
16	6H3-44552-03-94	HOUSING, LOWER MOUNT RUBBER CAJA AMORTIGUADOR INFERIOR HU	2	2	2	
17	97075-08025	BOLT PERNO	4	4	4	
18	92995-08100	WASHER ARANDELA	4	4	4	
19	90501-14M08	SPRING, COMPRESSION RESORTE DE COMPRESION	4	4	4	
20	90179-06066	NUT TUERCA	2	2	2	
21	6H3-44553-01-4D	COVER, LOWER MOUNT CUBIERTA,AMORTIGUADOR INFERIOR	2	2	2	
22	97885-06016	SCREW, PAN HEAD TORNILLO A MUESCA	2	2	2	
23	697-82127-01	WIRE, LEAD 2 CABLE CONDUCTOR 2	1			S(17.7") S(17.7")
	688-82127-02	WIRE, LEAD 2 CABLE CONDUCTOR 2	1	1	1	L(22.5"),X(25.5") L(22.5"),X(25.5")

F4

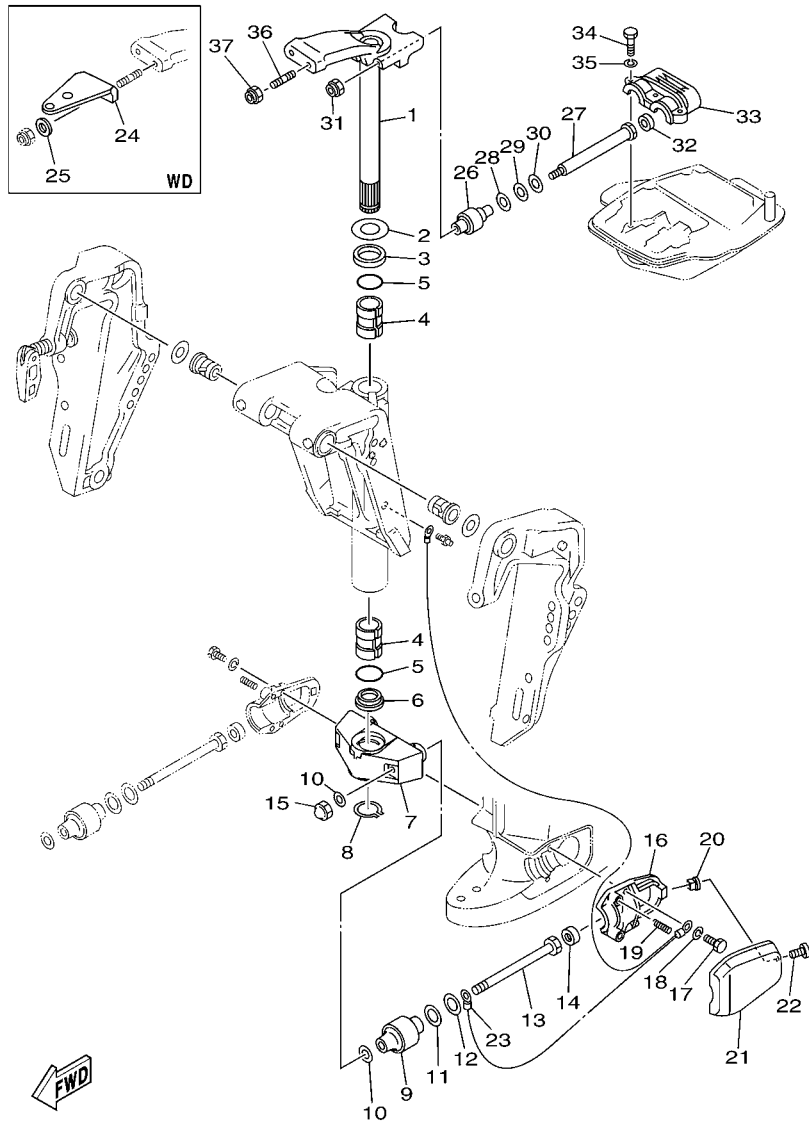

69D5200-E210

FIG. 21 BRACKET 4

SOPORTE 4

REF. NO.	PART NO. CODIGO Nº	DESCRIPTION DESCRIPCION	MHD	WHD	WD	REMARKS OBSERVACIONES
24	6H3-48511-51-4D	HOOK, STEERING GANCHO DIRECCION			1	STEERING GUIDE STEERING GUIDE
25	90201-10120	WASHER, PLATE ARANDELA PLANA			2	
26	688-44514-00-94	MOUNT DAMPER, UPPER SIDE AMORTIGUADOR LADO SUPERIOR	2	2	2	
27	90101-10M49	BOLT TORNILLO	2	2	2	
28	90201-20M21	WASHER, PLATE ARANDELA PLANA	2	2	2	
29	90202-20M06	WASHER, PLATE ARANDELA DE PLANA	2	2	2	
30	90201-11M22	WASHER, PLATE ARANDELA PLANA	2	2	2	
31	90185-10051	NUT, SELF-LOCKING TUERCA AUTOBLOCANTE	2	2	2	
32	663-44575-00	DAMPER, LOWER MOUNT RUBBER AMORTIGUADOR INFERIOR	2	2	2	
33	688-44511-00-94	COVER, UPPER MOUNT CUBIERTA AMORTIGUADOR SUPERIOR	1	1	1	
34	97075-08035	BOLT PERNO	3	3	3	
35	92995-08100	WASHER ARANDELA	3	3	3	
36	90116-10M28	BOLT, STUD ESPARRAGO	2	2	2	
37	90185-10051	NUT, SELF-LOCKING TUERCA AUTOBLOCANTE	2	2	2	

FIG. 22 UPPER CASING

FUNDA SUPERIOR

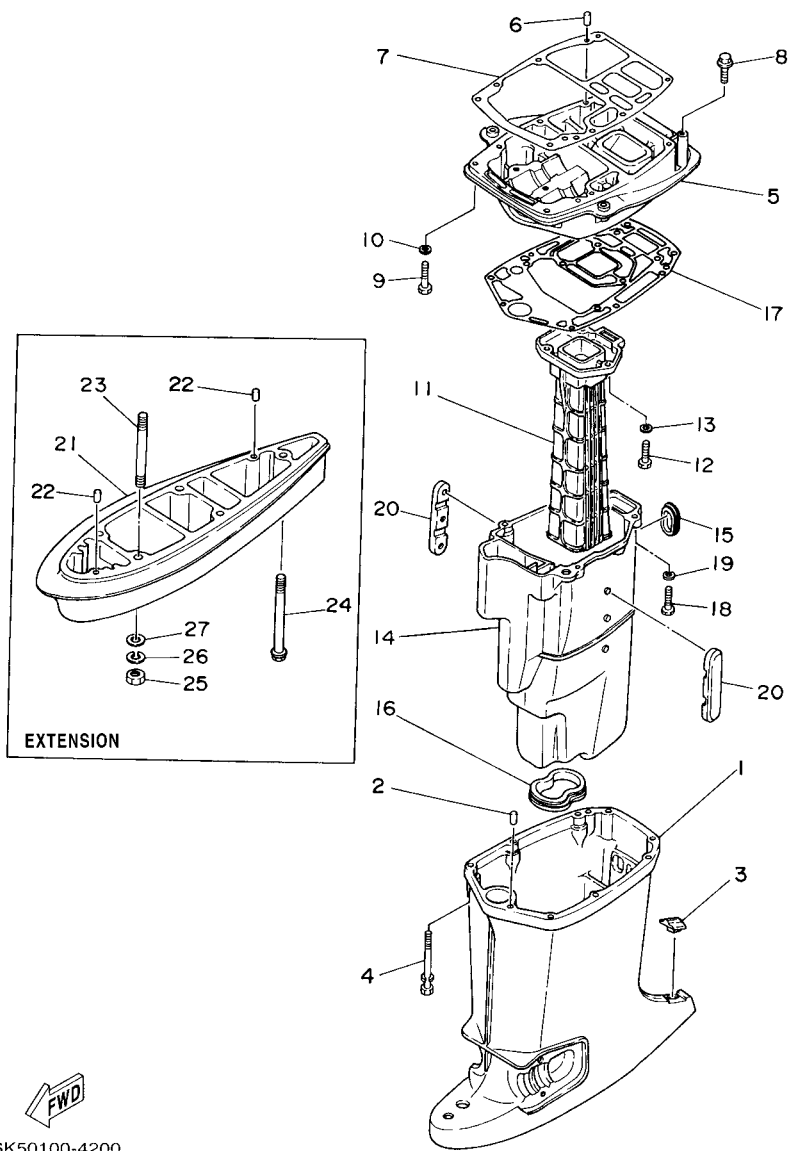

6K50100-4200

REF. NO.	PART NO. CODIGO Nº	DESCRIPTION DESCRIPCION	MHD	WHD	WD	REMARKS OBSERVACIONES
1	6H3-45111-01-4D	CASING, UPPER CAJA SUPERIOR	1			S(17.7") S(17.7")
	6H3-45111-12-4D	CASING, UPPER CAJA SUPERIOR	1	1	1	L(22.5"),X(25.5") L(22.5"),X(25.5")
2	93606-12019	PIN, DOWEL PASADOR DE CLAVIJA	2	2	2	
3	6H3-45155-00	CAP TAPA	1	1	1	
4	90119-08M81	BOLT, WITH WASHER TORNILLO CON ARANDELA	6	6	6	
5	6H3-41137-01-94	GUIDE, EXHAUST GUIA DE ESCAPE	1	1	1	
6	93606-12019	PIN, DOWEL PASADOR DE CLAVIJA	2	2	2	
7	6H3-45113-A0	GASKET, UPPER CASING EMPAQUE	1	1	1	
8	90119-08M79	BOLT, WITH WASHER TORNILLO CON ARANDELA	2	2	2	
9	97075-08035	BOLT PERNO	2	2	2	
10	92995-08100	WASHER ARANDELA	2	2	2	
11	6H2-41131-00-5B	MANIFOLD, EXT. 1 TUBO MULTIPLE DE ESCAPE	1	1	1	
	69D-41131-00-5B	MANIFOLD, EXT. 1 TUBO MULTIPLE DE ESCAPE		1		FOR YEM FOR YEM
12	97075-08030	BOLT PERNO	3	3	3	
13	92995-08100	WASHER ARANDELA	3	3	3	
14	6H3-14711-01-5B	MUFFLER 1 SILENCIADOR 1	1			S(17.7") S(17.7")
	6H3-14711-11-5B	MUFFLER 1 SILENCIADOR 1	1	1	1	L(22.5"),X(25.5") L(22.5"),X(25.5")
	69D-14711-10-5B	MUFFLER 1 SILENCIADOR 1		1		L(22.5")-FOR YEM L(22.5")-FOR YEM
15	6H3-45127-00	SEAL SELLO DE GOMA	1	1	1	
16	6H3-45123-00	GASKET, MUFFLER EMPAQUE SILENCIADOR	1	1	1	
17	6H3-45114-A1	GASKET, UPPER CASING EMPAQUE	1	1	1	
18	97075-08030	BOLT PERNO	4	4	4	
19	92995-08100	WASHER ARANDELA	4	4	4	
20	6H3-14737-00	DAMPER, MUFFLER AMORTIGUADOR DE SILENCIADOR	2			S(17.7") S(17.7")
	6H3-14737-10	DAMPER, MUFFLER AMORTIGUADOR DE SILENCIADOR	2	2	2	L(22.5"),X(25.5") L(22.5"),X(25.5")
21	696-45211-01-4D	EXTENSION EXTENSION	1	1	1	S(17.7"),L(22.5") S(17.7"),L(22.5")
	688-45211-01-4D	EXTENSION EXTENSION	1			X(25.5") X(25.5")

FIG. 22 UPPER CASING

FUNDA SUPERIOR

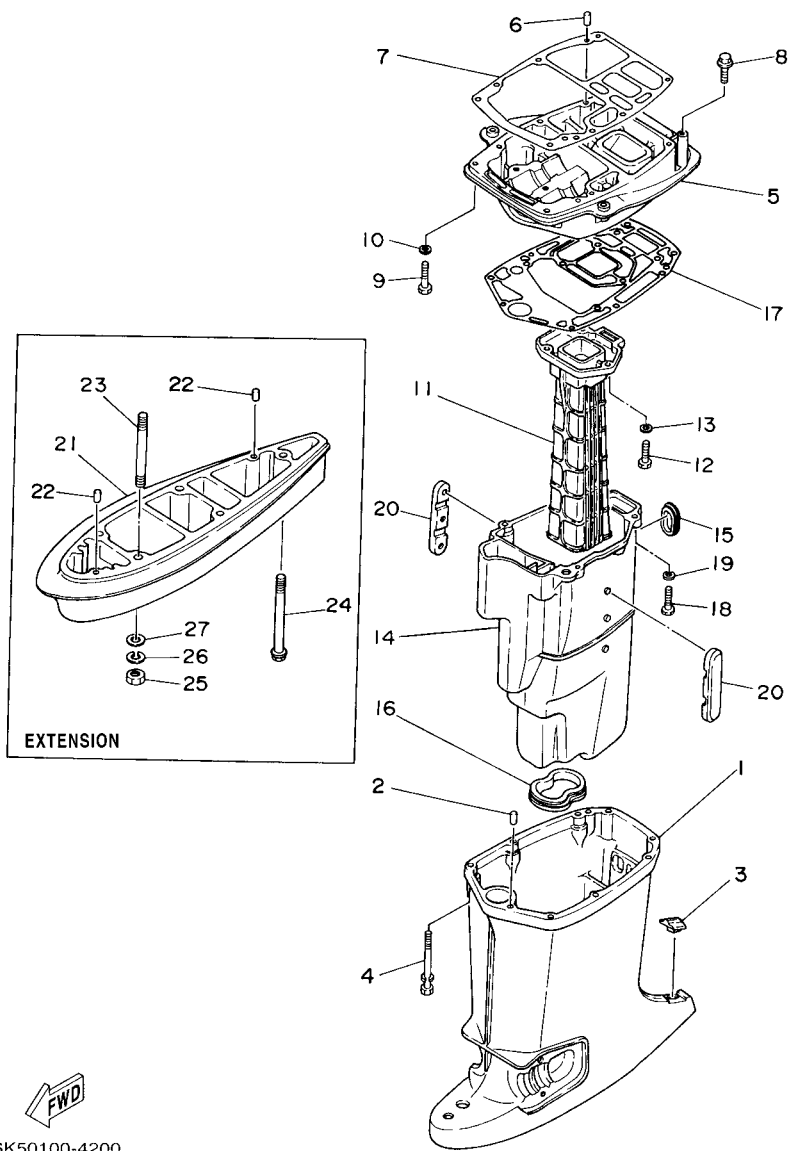

REF. NO.	PART NO. CODIGO Nº	DESCRIPTION DESCRIPCION	MHD	WHD	WD	REMARKS OBSERVACIONES
22	93606-12019	PIN, DOWEL PASADOR DE CLAVIJA	2	2	2	
23	90116-10M31	BOLT, STUD ESPARRAGO	4	4	4	S(17.7"),L(22.5") S(17.7"),L(22.5")
	90116-10M05	BOLT, STUD ESPARRAGO	4			X(25.5") X(25.5")
24	90119-08M85	BOLT, WITH WASHER TORNILLO CON ARANDELA	1	1	1	S(17.7"),L(22.5") S(17.7"),L(22.5")
	90119-08M86	BOLT, WITH WASHER TORNILLO CON ARANDELA	1			X(25.5") X(25.5")
25	95380-10600	NUT TUERCA	4	4	4	
26	92990-10100	WASHER, SPRING ARANDELA PLANA	4	4	4	
27	92990-10600	WASHER, PLATE ARANDELA PLANA	4	4	4	

FWD
6K50100-4200

FIG. 23 LOWER CASING & DRIVE 1 IMPULSOR E INFERIOR 1

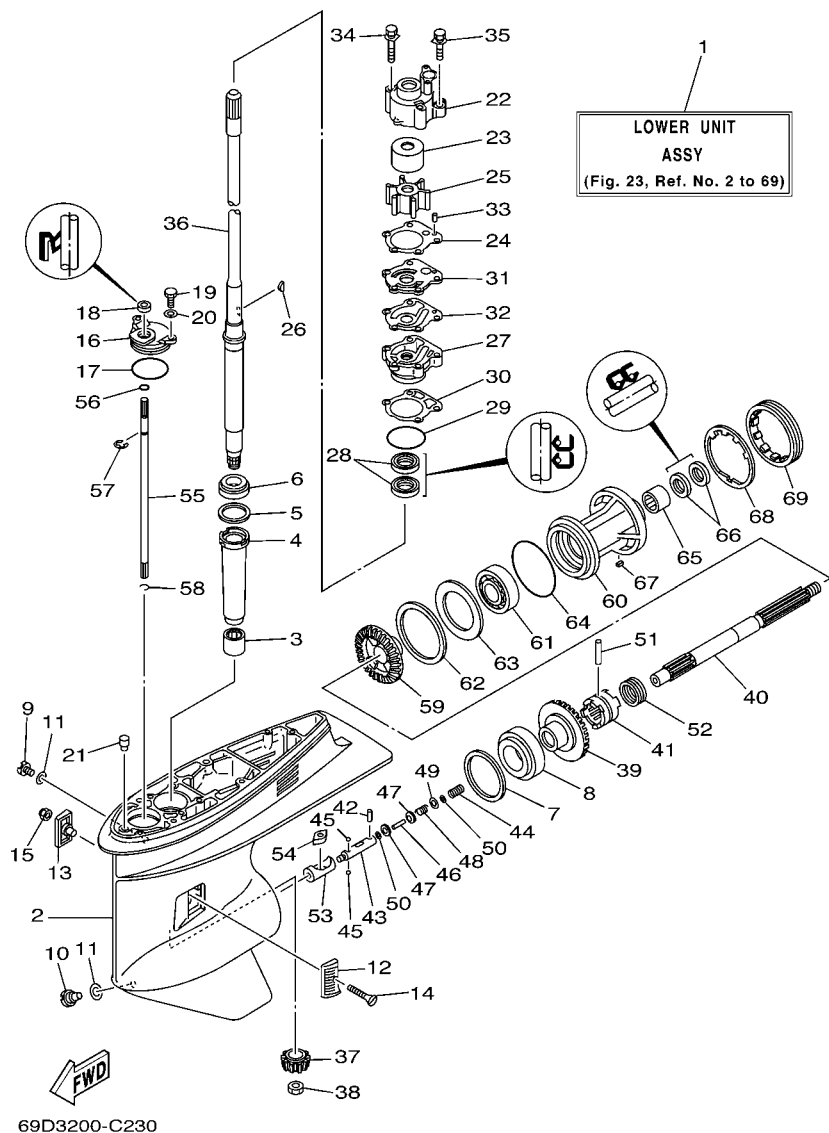

REF. NO.	PART NO. CODIGO Nº	DESCRIPTION DESCRIPCION	MHD	WHHD	WD	REMARKS OBSERVACIONES
1	69D-45300-00-4D	LOWER UNIT ASSY CONJUNTO UNIDAD INFERIOR	1			S (17.7") S (17.7")
	69D-45300-10-4D	LOWER UNIT ASSY CONJUNTO UNIDAD INFERIOR	1	1	1	L (22.5") L (22.5")
	69D-45300-20-4D	LOWER UNIT ASSY CONJUNTO UNIDAD INFERIOR	1			X (25.5") X (25.5")
2	6H1-45301-03-4D	CASING, LOWER FUNDA INFERIOR COMPLETA	1	1	1	
3	93315-325V1	BEARING COJINETE DE RODILLOS	1	1	1	
4	688-45536-01	SLEEVE, DRIVE SHAFT CAMISA EJE DE MANDO	1	1	1	
5	688-45587-01	SHIM (T:0.10MM) LAINA (T:0.10MM)	1	1	1	UR UR
	688-45587-10	SHIM (T:0.12MM) LAINA (T:0.12MM)	1	1	1	UR UR
	688-45587-20	SHIM (T:0.15MM) LAINA (T:0.15MM)	1	1	1	UR UR
	688-45587-30	SHIM (T:0.18MM) LAINA (T:0.18MM)	1	1	1	UR UR
	688-45587-40	SHIM (T:0.30MM) LAINA (T:0.30MM)	1	1	1	UR UR
	688-45587-50	SHIM (T:0.40MM) LAINA (T:0.40MM)	1	1	1	UR UR
	688-45587-60	SHIM (T:0.50MM) LAINA (T:0.50MM)	1	1	1	UR UR
6	93332-000U3	BEARING COJINETE	1	1	1	
7	688-45567-01	SHIM (T:0.10MM) LAINA(T:0.10MM)	1	1	1	UR UR
	688-45567-10	SHIM (T:0.12MM) LAINA (T:0.12MM)	1	1	1	UR UR
	688-45567-20	SHIM (T:0.15MM) LAINA (T:0.15MM)	1	1	1	UR UR
	688-45567-30	SHIM (T:0.18MM) LAINA (T:0.18MM)	1	1	1	UR UR
	688-45567-40	SHIM (T:0.30MM) LAINA (T:0.30MM)	1	1	1	UR UR
	688-45567-50	SHIM (T:0.40MM) LAINA (T:0.40MM)	1	1	1	UR UR
	688-45567-60	SHIM (T:0.50MM) LAINA (T:0.50MM)	1	1	1	UR UR
8	93332-000W7	BEARING COJINETE	1	1	1	
9	90340-08002	PLUG, STRAIGHT SCREW TORNILLO, DE DRENAJE	1	1	1	
10	688-45341-10	PLUG, DRAIN TAPON, DREN	1	1	1	
11	90430-08020	GASKET JUNTA	2	2	2	
12	6H1-45214-00	COVER, WATER INLET 1 CUBIERTA ENTRADA AGUA 1	1	1	1	
13	6H1-45215-00	COVER, WATER INLET 2 CUBIERTA ENTRADA AGUA 2	1	1	1	

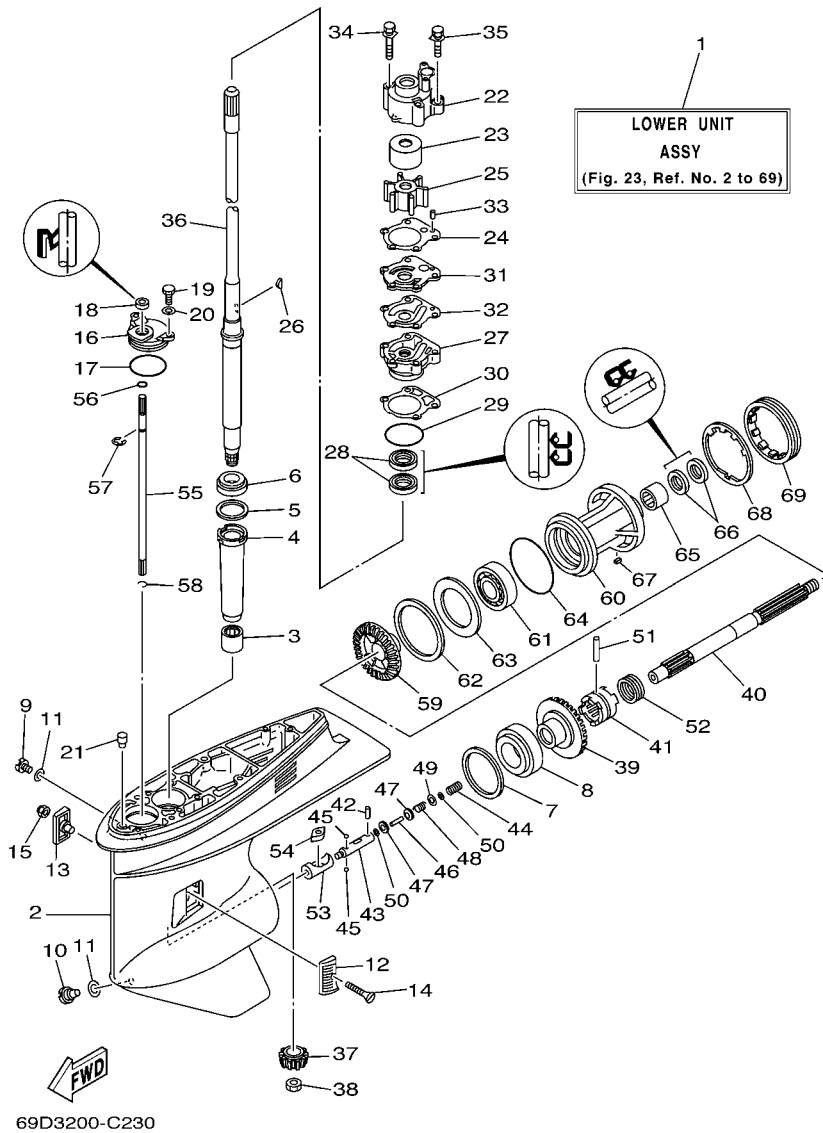

FIG. 23 LOWER CASING & DRIVE 1 IMPULSOR E INFERIOR 1

REF. NO.	PART NO. CODIGO Nº	DESCRIPTION DESCRIPCION	MHD	WHD	WD	REMARKS OBSERVACIONES
14	90151-05M00	SCREW, COUNTERSUNK TORNILLO EMBUTIDO	1	1	1	
15	90185-05002	NUT, SELF-LOCKING TUERCA AUTOBLOCANTE	1	1	1	
16	688-45321-00	PLATE PLACA	1	1	1	
17	93210-49046	O-RING ANILLO O	1	1	1	
18	93106-09014	OIL SEAL SELLO ACEITE	1	1	1	
19	97095-06016	BOLT PERNO	2	2	2	
20	92995-06600	WASHER ARANDELA	2	2	2	
21	6J8-45378-00	NIPPLE, HOSE NIPLE MANGUERA	1	1	1	
22	688-44311-01	HOUSING, WATER PUMP CAJA BOMBA DE AGUA	1	1	1	
23	69D-44322-00	INSERT, CARTRIDGE CARTUCHO	1	1	1	
24	688-44315-A0	GASKET, WATER PUMP EMPAQUE	1	1	1	
25	688-44352-03	IMPELLER IMPULSOR	1	1	1	
26	90280-04M04	KEY, WOODRUFF CUNA WOODRUFF	1	1	1	
27	688-44341-01-94	HOUSING, WATER PUMP CAJA BOMBA DE AGUA	1	1	1	
28	93101-25M03	OIL SEAL SELLO ACEITE	2	2	2	
29	93210-46044	O-RING ANILLO O	1	1	1	
30	688-44316-A0	GASKET, WATER PUMP EMPAQUE	1	1	1	
31	688-44323-40	OUTER PLATE, CARTRIDGE PLACA EXTERIOR DEL CARTUCHO	1	1	1	
32	688-44324-A0	GASKET, CARTRIDGE EMPAQUE	1	1	1	
33	93604-10M03	PIN, DOWEL PASADOR DE CLAVIJA	2	2	2	
34	90119-08M16	BOLT, WITH WASHER TORNILLO CON ARANDELA	2	2	2	
35	90119-08M13	BOLT, WITH WASHER TORNILLO CON ARANDELA	2	2	2	
36	69D-45501-00	DRIVE SHAFT COMP. EJE DE MANDO COMPL.	1			S (17.7")
	69D-45501-10	DRIVE SHAFT COMP. EJE DE MANDO COMPL.	1	1	1	L (22.5")
	69D-45501-20	DRIVE SHAFT COMP. EJE DE MANDO COMPL.	1			L (22.5")
		DRIVE SHAFT COMP. EJE DE MANDO COMPL.				X (25.5")
37	6K5-45551-00	PINION (12T) PINON (12T)	1	1	1	
38	90170-16M01	NUT TUERCA	1	1	1	

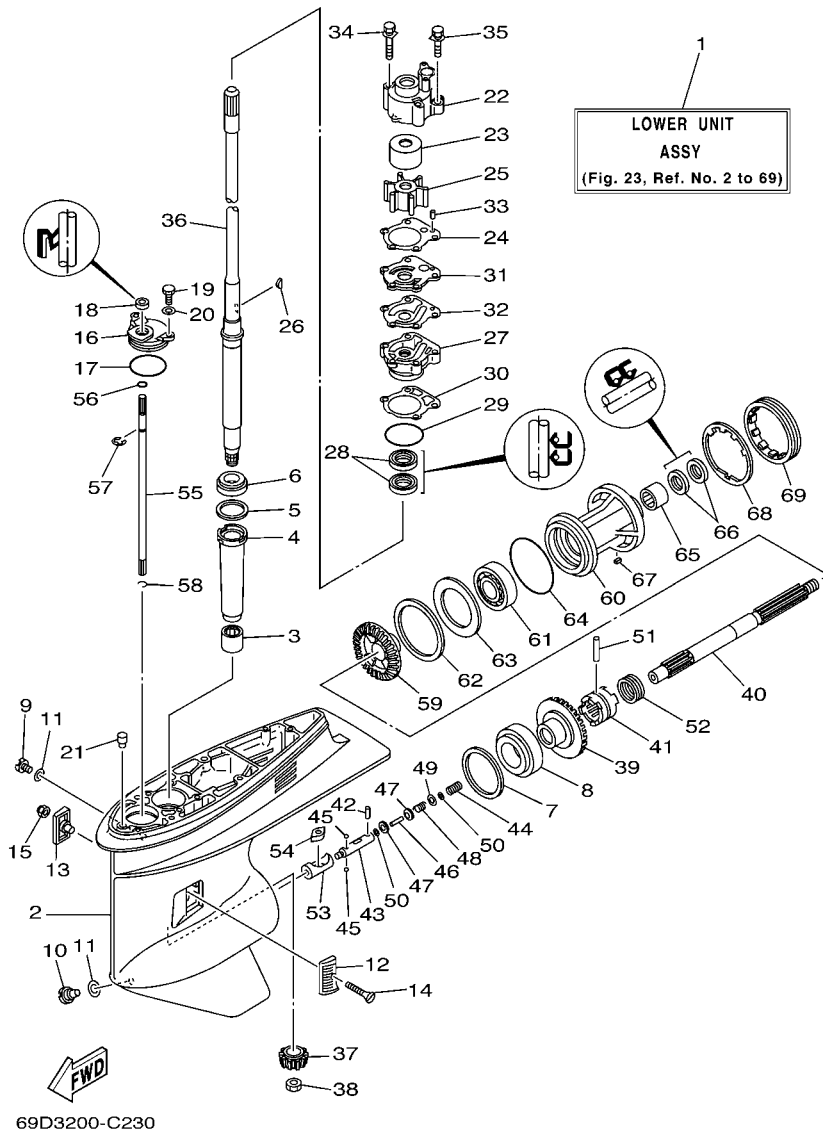
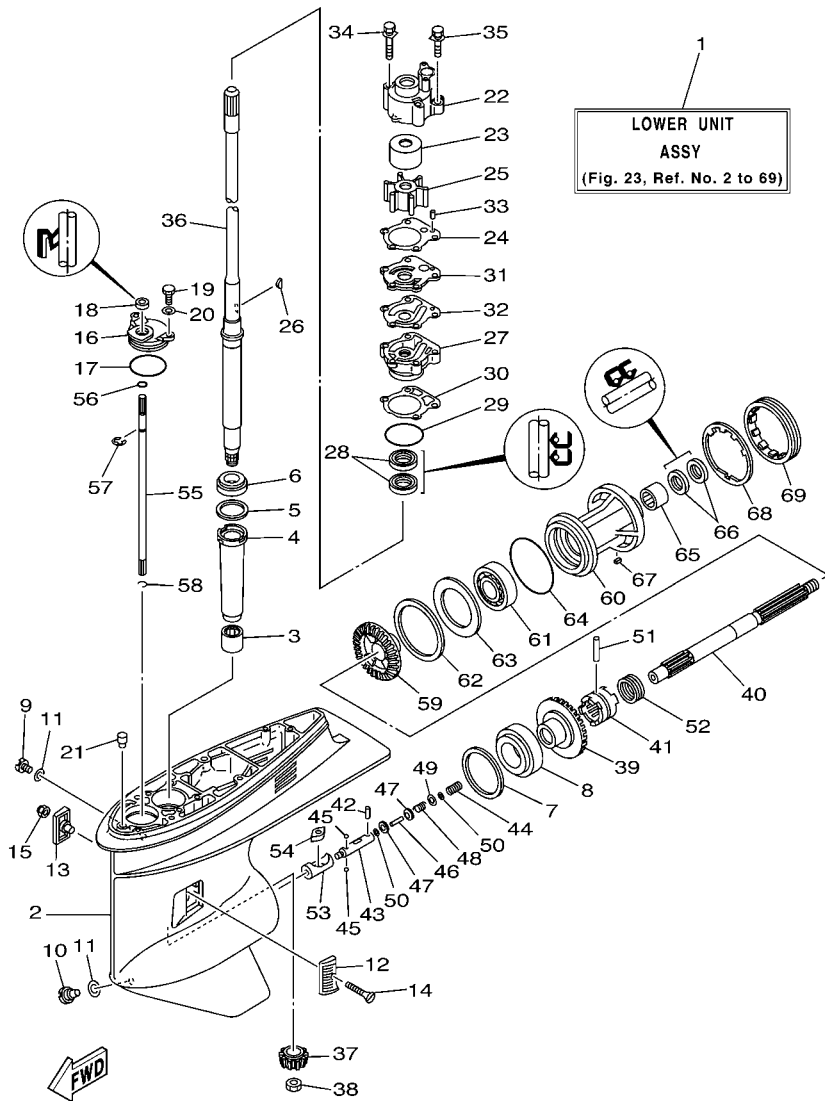

FIG. 23 LOWER CASING & DRIVE 1 IMPULSOR E INFERIOR 1

REF. NO.	PART NO. CODIGO Nº	DESCRIPTION DESCRIPCION	MHD	WHD	WD	REMARKS OBSERVACIONES
39	6K5-45560-00	GEAR (28T) ENGRANAJE (28T)	1	1	1	
40	6H1-45611-01	SHAFT, PROPELLER EJE PROPUSOR	1	1	1	
41	6H1-45631-01	CLUTCH, DOG EMBRAGUE DE GARRA	1	1	1	
42	93603-12M11	PIN, DOWEL PASADOR DE CLAVIJA	1	1	1	
43	6H1-45634-02	SLIDE, SHIFT DESILIZADOR, CAMBIO	1	1	1	
44	90501-16M65	SPRING, COMPRESSION RESORTE DE COMPRESION	1	1	1	
45	93503-16003	BALL ESFERA	2	2	2	
46	6H1-45668-00	SHAFT, FREE EJE	1	1	1	
47	6H1-45635-00	PLUNGER, SHIFT EMBOLO DE CAMBIO	2	2	2	
48	90501-12M48	SPRING, COMPRESSION RESORTE DE COMPRESION	1	1	1	
49	90201-03313	WASHER, PLATE ARANDELA PLANA	1	1	1	
50	90183-02M03	NUT, SPRING TUERCA DE RESORTE	2	2	2	
51	90250-07M02	PIN, STRAIGHT PASADOR CILINDRICO	1	1	1	
52	688-45633-00	RING, CROSS PIN ANILLO DE PASADOR	1	1	1	
53	6H1-45641-01	SHIFTER CAMBIO	1	1	1	
54	6H1-44151-00	CAM, SHIFT LEVA DE CAMBIO	1	1	1	
55	6H1-44144-00	ROD, SHIFT VARILLA DE CAMBIO	1	1	1	
56	93210-07003	O-RING ANILLO O	1	1	1	
57	99001-08600	CIRCLIP PRESILLA REDONDA	1	1	1	
58	93450-07M00	CIRCLIP SEGURO	1	1	1	
59	6H3-45571-00	GEAR (28T) ENGRANAJE (28T)	1	1	1	
60	688-45331-00-94	HOUSING, BEARING CAJA DE COJINETE	1	1	1	
61	93306-207U0	BEARING COJINETE	1	1	1	
62	688-45577-01	SHIM (T:0.10MM) LAINA (T:0.10MM)	1	1	1	UR
	688-45577-10	SHIM (T:0.12MM) LAINA (T:0.12MM)	1	1	1	UR
	688-45577-20	SHIM (T:0.15MM) LAINA (T:0.15MM)	1	1	1	UR
	688-45577-30	SHIM (T:0.18MM) LAINA (T:0.18MM)	1	1	1	UR



69D3200-C230

FIG. 23 LOWER CASING & DRIVE 1 IMPULSOR E INFERIOR 1

REF. NO.	PART NO. CODIGO Nº	DESCRIPTION DESCRIPCION	MHD	WHD	WD	REMARKS OBSERVACIONES
62	688-45577-40	SHIM (T:0.30MM) LAINA (T:0.30MM)	1	1	1	UR
	688-45577-50	SHIM (T:0.40MM) LAINA (T:0.40MM)	1	1	1	UR
	688-45577-60	SHIM (T:0.50MM) LAINA (T:0.50MM)	1	1	1	UR
63	688-45576-00	WASHER, THRUST ARANDELA DE EMPUJE AXIAL	1	1	1	UR
64	93210-85M97	O-RING ANILLO O	1	1	1	
65	93317-325U0	BEARING COJINETE	1	1	1	
66	93101-25M03	OIL SEAL SELLO ACEITE	2	2	2	
67	90282-04010	KEY, STRAIGHT CHAVETA, RECTA	1	1	1	
68	688-45383-02	WASHER, CLAW ARANDELA DE UNA	1	1	1	
69	688-45384-00	NUT TUERCA	1	1	1	

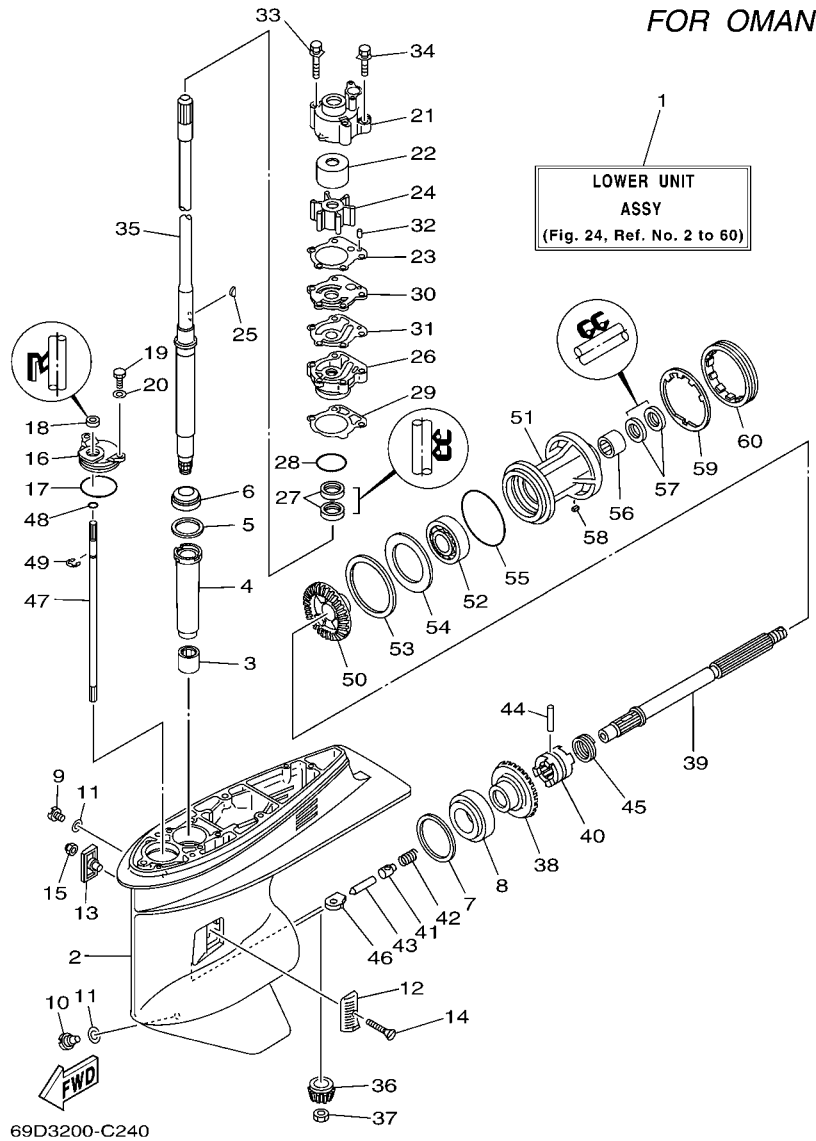

FIG. 24 LOWER CASING & DRIVE 2 IMPULSOR E INFERIOR 2

REF. NO.	PART NO. CODIGO Nº	DESCRIPTION DESCRIPCION	MHD	WHD	WD	REMARKS OBSERVACIONES
1	69D-45300-40-4D	LOWER UNIT ASSY CONJUNTO UNIDAD INFERIOR	1	1		L (22.5") L (22.5")
2	688-45311-06-4D	CASING, LOWER FUNDA INFERIOR	1	1		
3	93315-325V1	BEARING COJINETE DE RODILLOS	1	1		
4	688-45536-01	SLEEVE, DRIVE SHAFT CAMISA EJE DE MANDO	1	1		
5	688-45587-01	SHIM (T:0.10MM) LAINA (T:0.10MM)	1	1		UR UR
688-45587-10	SHIM (T:0.12MM) LAINA (T:0.12MM)		1	1		UR UR
688-45587-20	SHIM (T:0.15MM) LAINA (T:0.15MM)		1	1		UR UR
688-45587-30	SHIM (T:0.18MM) LAINA (T:0.18MM)		1	1		UR UR
688-45587-40	SHIM (T:0.30MM) LAINA (T:0.30MM)		1	1		UR UR
688-45587-50	SHIM (T:0.40MM) LAINA (T:0.40MM)		1	1		UR UR
688-45587-60	SHIM (T:0.50MM) LAINA (T:0.50MM)		1	1		UR UR
6	93332-000U3	BEARING COJINETE	1	1		
7	688-45567-01	SHIM (T:0.10MM) LAINA(T:0.10MM)	1	1		UR UR
688-45567-10	SHIM (T:0.12MM) LAINA (T:0.12MM)		1	1		UR UR
688-45567-20	SHIM (T:0.15MM) LAINA (T:0.15MM)		1	1		UR UR
688-45567-30	SHIM (T:0.18MM) LAINA (T:0.18MM)		1	1		UR UR
688-45567-40	SHIM (T:0.30MM) LAINA (T:0.30MM)		1	1		UR UR
688-45567-50	SHIM (T:0.40MM) LAINA (T:0.40MM)		1	1		UR UR
688-45567-60	SHIM (T:0.50MM) LAINA (T:0.50MM)		1	1		UR UR
8	93332-000W7	BEARING COJINETE	1	1		
9	90340-08002	PLUG, STRAIGHT SCREW TORNILLO, DE DRENAJE	1	1		
10	688-45341-10	PLUG, DRAIN TAPON, DREN	1	1		
11	90430-08020	GASKET JUNTA	2	2		
12	6H1-45214-00	COVER, WATER INLET 1 CUBIERTA ENTRADA AGUA 1	1	1		
13	6H1-45215-00	COVER, WATER INLET 2 CUBIERTA ENTRADA AGUA 2	1	1		
14	90151-05M00	SCREW, COUNTERSUNK TORNILLO EMBUTIDO	1	1		
15	90185-05002	NUT, SELF-LOCKING TUERCA AUTOBLOCANTE	1	1		

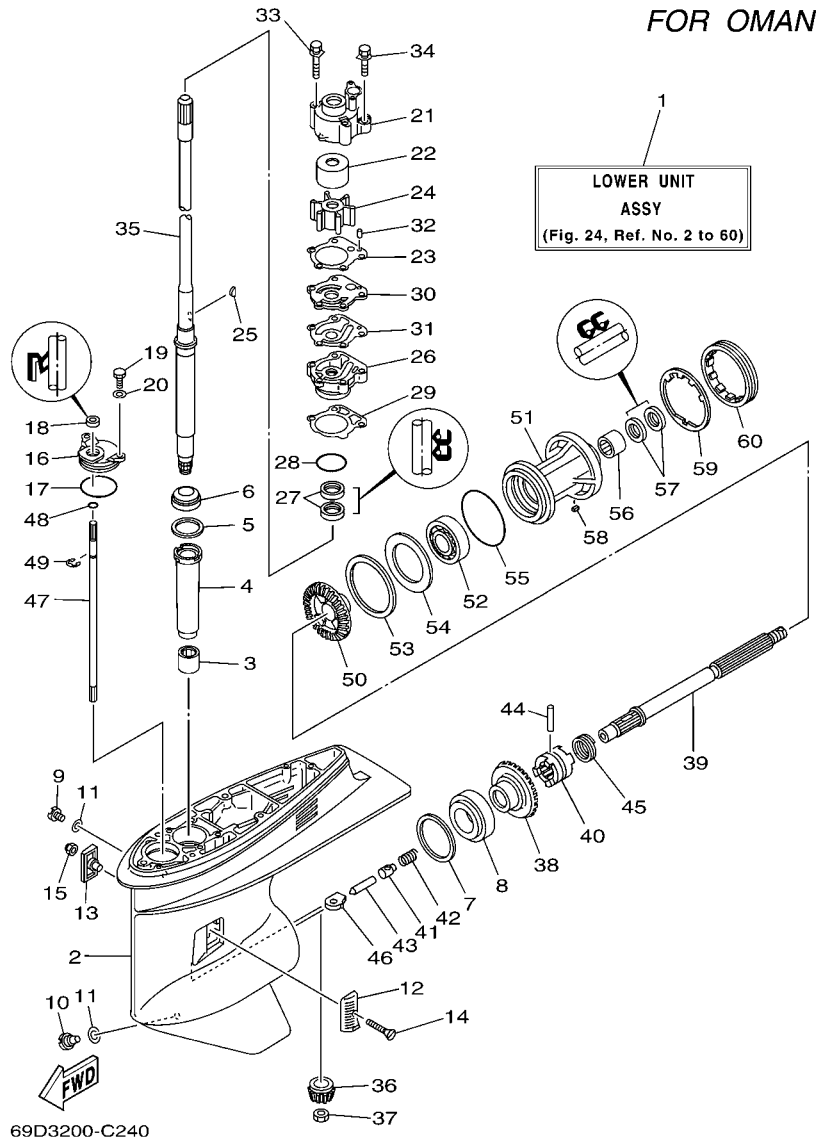

FIG. 24 LOWER CASING & DRIVE 2 IMPULSOR E INFERIOR 2

REF. NO.	PART NO. CODIGO Nº	DESCRIPTION DESCRIPCION	MHD	WHD	WD	REMARKS OBSERVACIONES
16	688-45321-00	PLATE PLACA	1	1		
17	93210-49046	O-RING ANILLO O	1	1		
18	93106-09014	OIL SEAL SELLO ACEITE	1	1		
19	97095-06016	BOLT PERNO	2	2		
20	92995-06600	WASHER ARANDELA	2	2		
21	688-44311-01	HOUSING, WATER PUMP CAJA BOMBA DE AGUA	1	1		
22	69D-44322-00	INSERT, CARTRIDGE CARTUCHO	1	1		
23	688-44315-A0	GASKET, WATER PUMP EMPAQUE	1	1		
24	688-44352-03	IMPELLER IMPULSOR	1	1		
25	90280-04M04	KEY, WOODRUFF CUNA WOODRUFF	1	1		
26	688-44341-01-94	HOUSING, WATER PUMP CAJA BOMBA DE AGUA	1	1		
27	93101-25M03	OIL SEAL SELLO ACEITE	2	2		
28	93210-46044	O-RING ANILLO O	1	1		
29	688-44316-A0	GASKET, WATER PUMP EMPAQUE	1	1		
30	688-44323-40	OUTER PLATE, CARTRIDGE PLACA EXTERIOR DEL CARTUCHO	1	1		
31	688-44324-A0	GASKET, CARTRIDGE EMPAQUE	1	1		
32	93604-10M03	PIN, DOWEL PASADOR DE CLAVIJA	2	2		
33	90119-08M16	BOLT, WITH WASHER TORNILLO CON ARANDELA	2	2		
34	90119-08M13	BOLT, WITH WASHER TORNILLO CON ARANDELA	2	2		
35	69D-45501-10	DRIVE SHAFT COMP. EJE DE MANDO COMPL.	1	1		L (22.5") L (22.5")
36	6K5-45551-00	PINION (12T) PINON (12T)	1	1		
37	90170-16M01	NUT TUERCA	1	1		
38	6K5-45560-00	GEAR (28T) ENGRANAJE (28T)	1	1		
39	688-45611-00	SHAFT, PROPELLER EJE PROPUSOR	1	1		
40	688-45631-01	CLUTCH, DOG EMBRAGUE DE GARRA	1	1		
41	688-45634-00	SLIDE, SHIFT DESILIZADOR, CAMBIO	1	1		
42	90501-16233	SPRING, COMPRESSION RESORTE DE COMPRESION	1	1		

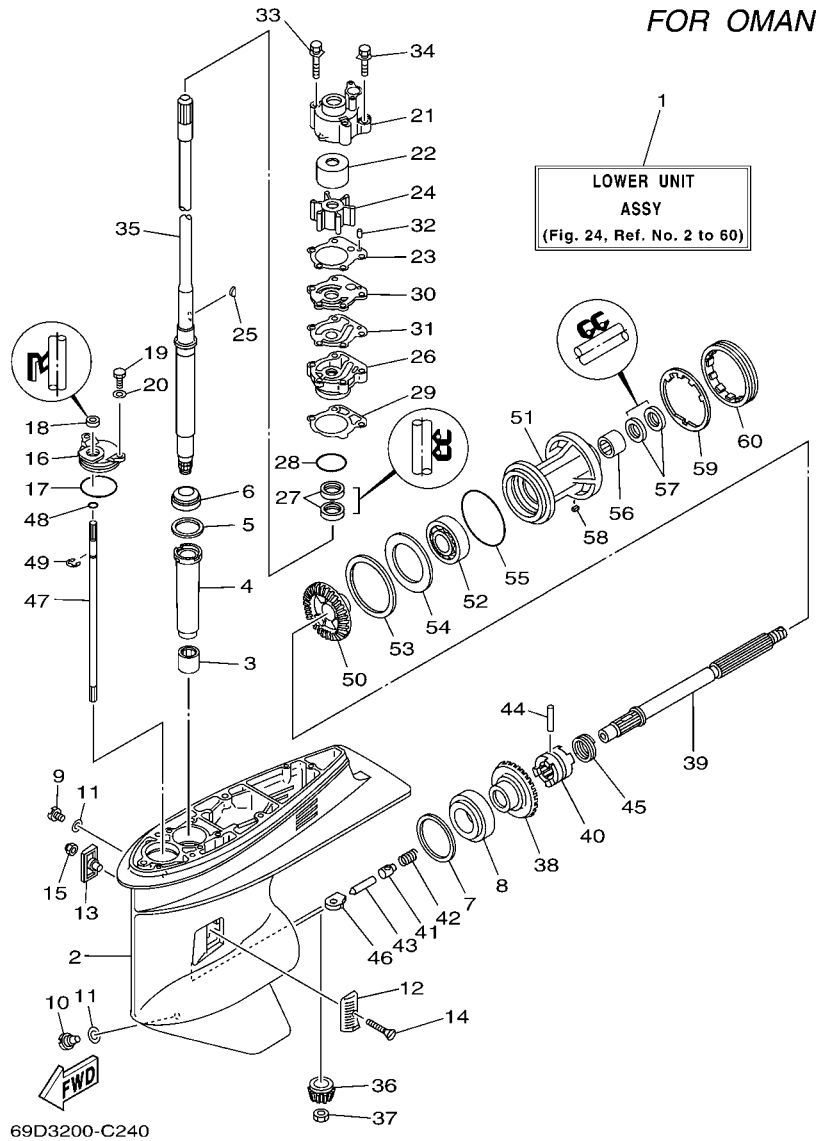
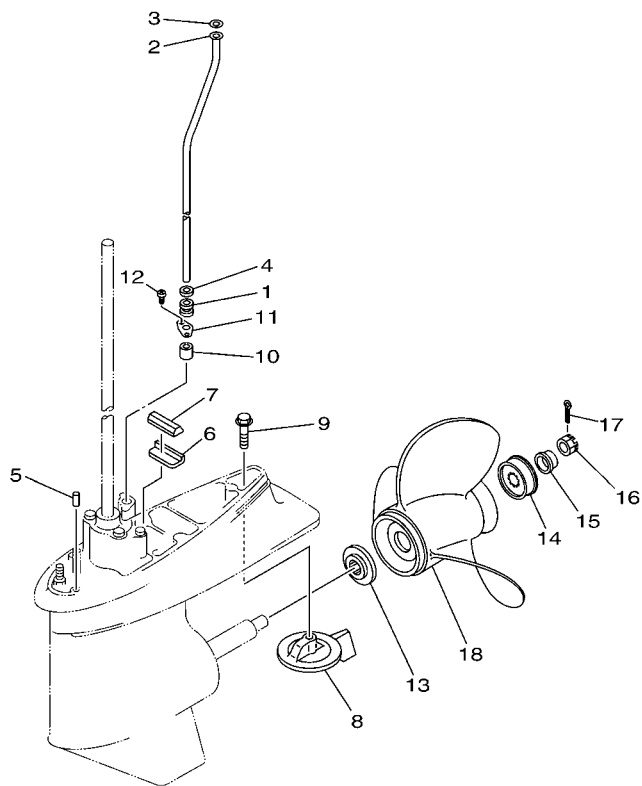

FIG. 24 LOWER CASING & DRIVE 2 IMPULSOR E INFERIOR 2

REF. NO.	PART NO. CODIGO Nº	DESCRIPTION DESCRIPCION	MHD	WHD	WD	REMARKS OBSERVACIONES
43	688-45635-00	PLUNGER, SHIFT EMBOLO DE CAMBIO	1	1		
44	90250-07M02	PIN, STRAIGHT PASADOR CILINDRICO	1	1		
45	688-45633-00	RING, CROSS PIN ANILLO DE PASADOR	1	1		
46	663-44151-00	CAM, SHIFT LEVA DE CAMBIO	1	1		
47	6K5-44144-00	ROD, SHIFT VARILLA DE CAMBIO	1	1		
48	93210-07003	O-RING ANILLO O	1	1		
49	99001-08600	CIRCLIP PRESILLA REDONDA	1	1		
50	6K5-45571-00	GEAR (28T) ENGRANAJE (28T)	1	1		
51	688-45331-00-94	HOUSING, BEARING CAJA DE COJINETE	1	1		
52	93306-207U0	BEARING COJINETE	1	1		
53	688-45577-01	SHIM (T:0.10MM) LAINA (T:0.10MM)	1	1		UR
	688-45577-10	SHIM (T:0.12MM) LAINA (T:0.12MM)	1	1		UR
	688-45577-20	SHIM (T:0.15MM) LAINA (T:0.15MM)	1	1		UR
	688-45577-30	SHIM (T:0.18MM) LAINA (T:0.18MM)	1	1		UR
	688-45577-40	SHIM (T:0.30MM) LAINA (T:0.30MM)	1	1		UR
	688-45577-50	SHIM (T:0.40MM) LAINA (T:0.40MM)	1	1		UR
	688-45577-60	SHIM (T:0.50MM) LAINA (T:0.50MM)	1	1		UR
54	688-45576-00	WASHER, THRUST ARANDELA DE EMPUJE AXIAL	1	1		
55	93210-85M97	O-RING ANILLO O	1	1		
56	93317-325U0	BEARING COJINETE	1	1		
57	93101-25M03	OIL SEAL SELLO ACEITE	2	2		
58	90282-04010	KEY, STRAIGHT CHAVETA, RECTA	1	1		
59	688-45383-02	WASHER, CLAW ARANDELA DE UNA	1	1		
60	688-45384-00	NUT TUERCA	1	1		

FIG. 25 LOWER CASING & DRIVE 3

IMPULSOR E INFERIOR 3



69D3700-C170

REF. NO.	PART NO. CODIGO Nº	DESCRIPTION DESCRIPCION	MHD	WHD	WD	REMARKS OBSERVACIONES
1	663-44367-00	DAMPER, WATER SEAL GOMA DEL SELLO DE AGUA	1	1	1	
2	69D-44361-00	TUBE, WATER TUBO DE AGUA	1			S (17.7") S (17.7")
	69D-44361-10	TUBE, WATER TUBO DE AGUA	1	1	1	L (22.5") L (22.5")
	69D-44361-20	TUBE, WATER TUBO DE AGUA	1			X (25.5") X (25.5")
3	90202-12060	WASHER, PLATE ARANDELA DE PLANA	1	1	1	
4	90430-12072	GASKET JUNTA	1	1	1	
5	93606-12019	PIN, DOWEL PASADOR DE CLAVIJA	2	2	2	
6	663-45376-00-94	GUIDE, SEAL DAMPER GUIA DE SELLO GOMA	1	1	1	
7	688-45375-00	DAMPER, SEAL GOMA DE SELLO	1	1	1	
8	688-45371-02	TAB-TRIM QUILLA ESTABILIZADOR	1	1	1	
9	90105-10M67	BOLT, FLANGE TORNILLO	1	1	1	
10	663-44366-00	DAMPER, WATER SEAL GOMA DEL SELLO DE AGUA	1	1	1	
11	90480-19M06	GROMMET TAPON	1	1	1	
12	97780-40512	SCREW, TAPPING TORNILLO DE CABEZA DE CONO ACH	2	2	2	
13	688-45987-01	SPACER ESPACIADOR	1	1	1	
14	67F-45997-00	SPACER ESPACIADOR	1	1	1	
15	90389-25M00	BUSH BUJE	1	1	1	
16	90171-16011	NUT, CASTLE TUERCA ENTALLADA	1	1	1	
17	91490-40025	PIN, COTTER CHAVETA	1	1	1	
18	6E5-45941-00-EL	PROPELLER (3X13"X19"-K) PROPELA (3X13"X19"-K)	1	1	1	UR UR
	6E5-45943-00-EL	PROPELLER (3X12-5/8"X21"-K) PROPELA (3X12-5/8"X21"-K)	1	1	1	UR UR
	6E5-45945-01-EL	PROPELLER (3X13-1/4"X17"-K) PROPELA (3X13-1/4"X17"-K)	1	1	1	UR UR
	6E5-45947-00-EL	PROPELLER (3X13-1/2"X15"-K) PROPELA (3X13-1/2"X15"-K)	1	1	1	UR UR
	6E5-45949-00-EL	PROPELLER (3X13-5/8"X13"-K) PROPELA (3X13-5/8"X13"-K)	1	1	1	UR UR
	6E5-45952-00-EL	PROPELLER (3X13"X23"-K) PROPELA (3X13"X23"-K)	1	1	1	UR UR
	6E5-45954-00-EL	PROPELLER (3X14"X11"-K) PROPELA (3X14"X11"-K)	1	1	1	UR UR
	6E5-45956-00-EL	PROPELLER (3X13"X25"-K) PROPELA (3X13"X25"-K)	1	1	1	UR UR

B4

FIG. 25 LOWER CASING & DRIVE 3 IMPULSOR E INFERIOR 3

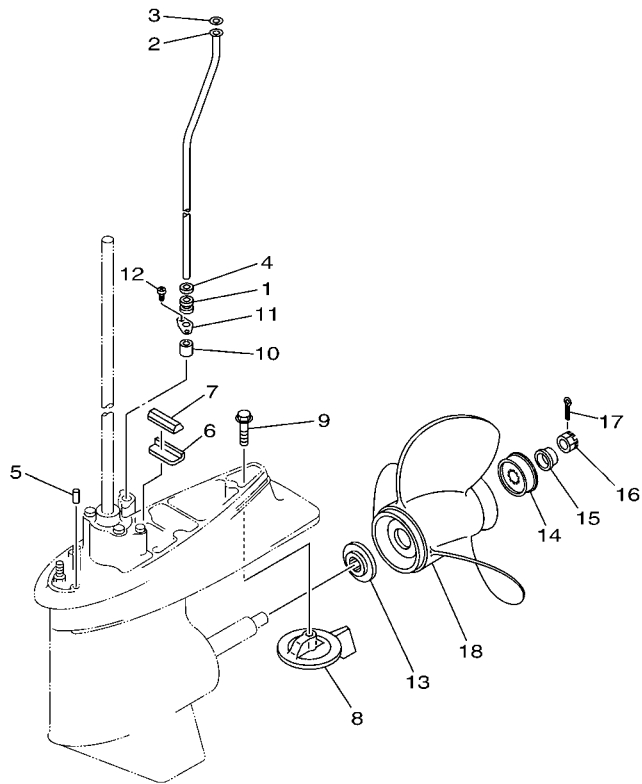

REF. NO.	PART NO. CODIGO Nº	DESCRIPTION DESCRIPCION	MHD	WHD	WD	REMARKS OBSERVACIONES
18	688-45930-02-98	PROPELLER (3X13"X17"-K) PROPELA (3X13"X17"-K)	1	1	1	UR UR
	688-45970-03-98	PROPELLER (3X13"X19"-K) PROPELA (3X13"X19"-K)	1	1	1	UR UR
	688-45972-02-98	PROPELLER (3X13"X21"-K) PROPELA (3X13"X21"-K)	1	1	1	UR UR
	688-45974-02-98	PROPELLER (3X13"X23"-K) PROPELA (3X13"X23"-K)	1	1	1	UR UR
	688-45976-01-98	PROPELLER (3X13"X25"-K) PROPELA (3X13"X25"-K)	1	1	1	UR UR
	688-45932-60-98	PROPELLER (3X13-1/2"X14"-K) PROPELA (3X13-1/2"X14"-K)	1	1	1	UR UR
	688-45978-60-98	PROPELLER (3X13-1/2"X16"-K) PROPELA (3X13-1/2"X16"-K)	1	1	1	UR UR

69D3700-C170

FIG. 26 FUEL TANK

DEPOSITO DE COMBUSTIBLE

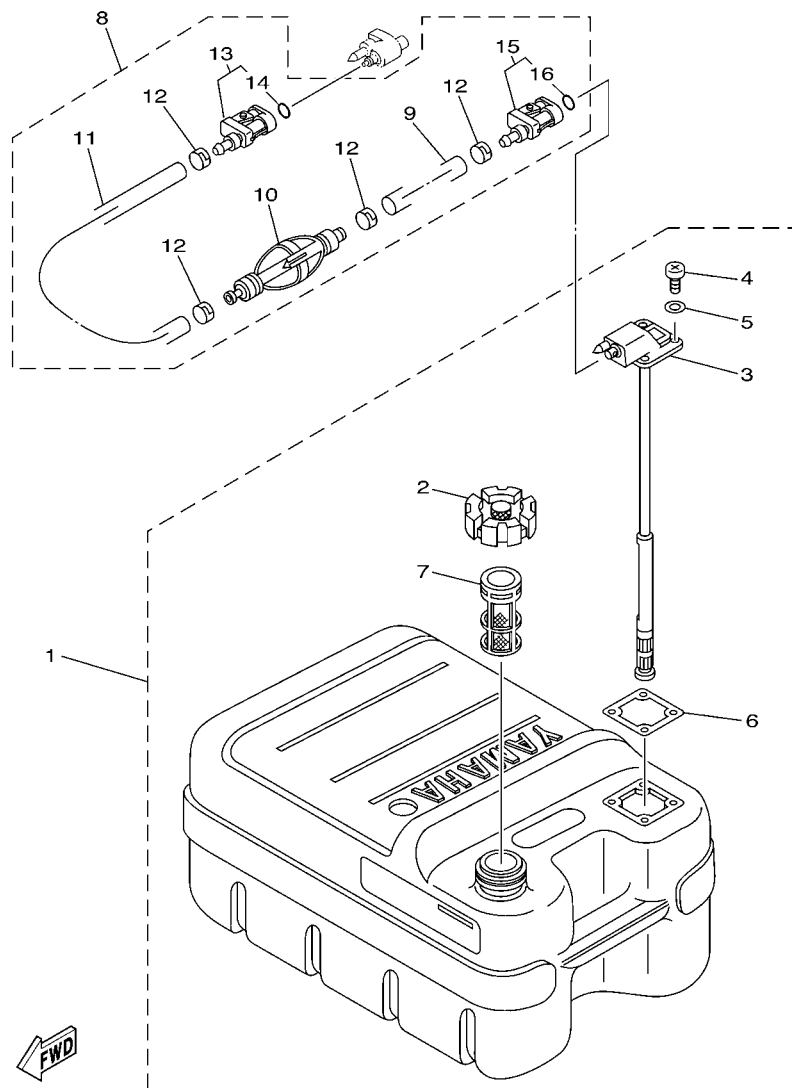

68U3100-C240

REF. NO.	PART NO. CODIGO Nº	DESCRIPTION DESCRIPCION	MHD	WHD	WD	REMARKS OBSERVACIONES
1	6YJ-24201-00	FUEL TANK ASSY (24L) TANQUE DEL COMBUSTIBLE (24L)	1	1	1	AP AP
	6YJ-24201-10	FUEL TANK ASSY (24L) TANQUE DEL COMBUSTIBLE (24L)	1	1	1	AP FOR CHN,TWN AP FOR CHN,TWN
2	6YJ-24610-01	.CAP ASSY .TAPA COMPLETA	1	1	1	
3	6YJ-24260-00	.FUEL METER ASSY .MEDIDOR DE COMBUSTIBLE COMPL.	1	1	1	
	6Y1-24260-12	.FUEL METER ASSY .MEDIDOR DE COMBUSTIBLE COMPL.	1	1	1	FOR CHN,TWN FOR CHN,TWN
4	98586-05016	.SCREW, PAN HEAD .TORNILLO DE CABEZA CON PLANA	4	4	4	
5	6Y1-24329-00	.SEAL .SELLO	4	4	4	
6	6Y1-24268-00	.GASKET, FUEL METER .EMPAQ MEDIDOR DE COMBUSTIBLE	1	1	1	
7	6YJ-24167-00	.STRAINER .COLADOR	1	1	1	
8	61J-24306-04	FUEL PIPE COMP. 1 TUBO COMBUST. COMPL 1	1	1	1	AP AP
9	90445-11M06	.HOSE (L2050) .MANGUERA (L2050)	1	1	1	
10	61J-24360-00	.PRIMER PUMP ASSY .SOPORTE BOMBA	1	1	1	
11	90445-11M05	.HOSE (L850) .MANGUERA (L850)	1	1	1	
12	650-24351-01	.BAND 1 .ABRAZADERA 1	4	4	4	
13	6G1-24305-05	.FUEL PIPE JOINT COMP. 2 .CONECTOR MANGUERA COMBUST. 2	1	1	1	
14	93210-08287	..O-RING ..ANILLO O	1	1	1	
15	6Y1-24305-06	.FUEL PIPE JOINT COMP. 2 .CONECTOR MANGUERA COMBUST. 2	1	1	1	
16	93210-08287	..O-RING ..ANILLO O	1	1	1	

FIG. 27 STEERING GUIDE

DIRECCIONGUIAR

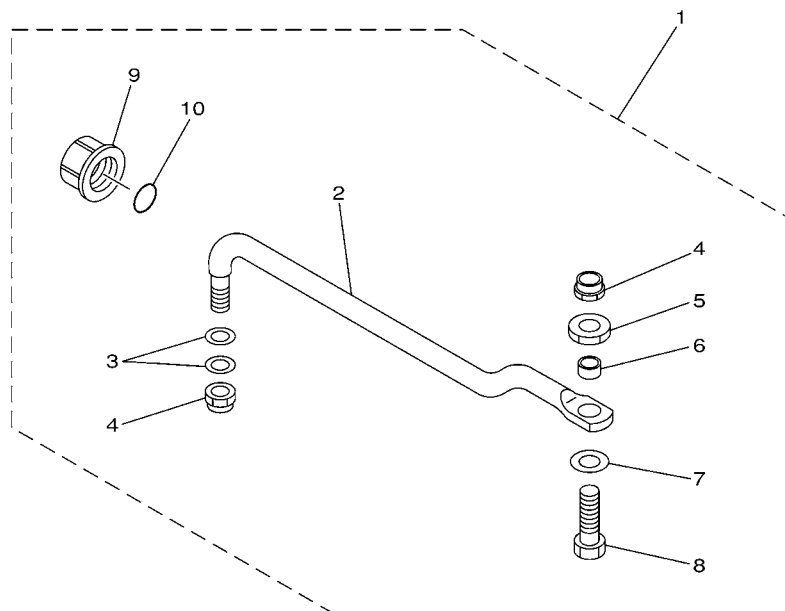

REF. NO.	PART NO. CODIGO Nº	DESCRIPTION DESCRIPCION	MHD	WHD	WD	REMARKS OBSERVACIONES
1	688-61350-10	STEERING GUIDE ATTACHMENT KIT ESTUCHE ADITAMENTO GUIA DE TIM			1	AP AP
2	688-61351-10	.ROD, STEERING LINK .VARILLA ESLABON DIRECCION			1	
3	90201-10M20	.WASHER, PLATE .ARANDELA PLANA			2	
4	90185-09M01	.NUT, SELF-LOCKING .TUERCA AUTOBLOCANTE			2	
5	90170-09M03	.NUT .TUERCA			1	
6	90387-10M42	.COLLAR .ESPACIADOR			1	
7	90201-10M63	.WASHER, PLATE .ARANDELA PLANA			1	
8	6E5-61355-00	.BOLT .TORNILLO			1	
9	6E5-43145-01	.CAP, CLAMP BRACKET .TAPA			1	
10	93210-16275	.O-RING .ANILLO O			1	

6880700-9190

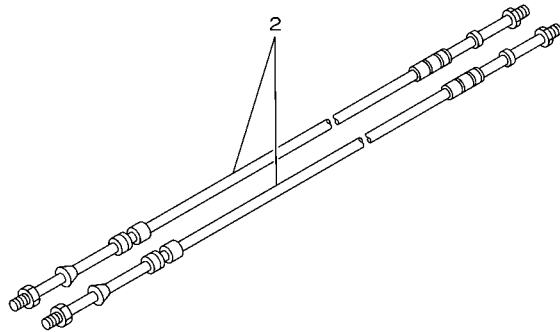
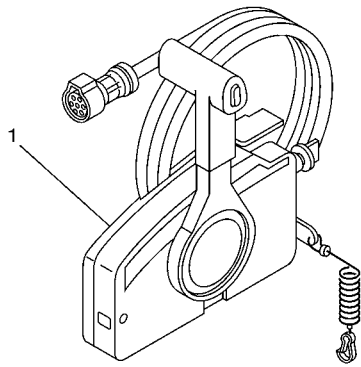

67M0100-8280

FIG. 28 REMOTE CONTROL BOX

CONTROL REMOTO COMPLETO

REF. NO.	PART NO. CODIGO Nº	DESCRIPTION DESCRIPCION	MHD	WHD	WD	REMARKS OBSERVACIONES
1	703-48230-15	REMOTE CONTROL ASSY (7P) CONTROL REMOTO COMPL. (7P)			1	AP WITHOUT PT/T SW. AP WITHOUT PT/T SW.
2	701-48320-20	CABLE, REMOTE CONTROL L=13F CABLE CONTROL REMOTO L=13F			2	UR UR
	701-48320-50	CABLE, REMOTE CONTROL L=15F CABLE CONTROL REMOTO L=15F			2	UR UR

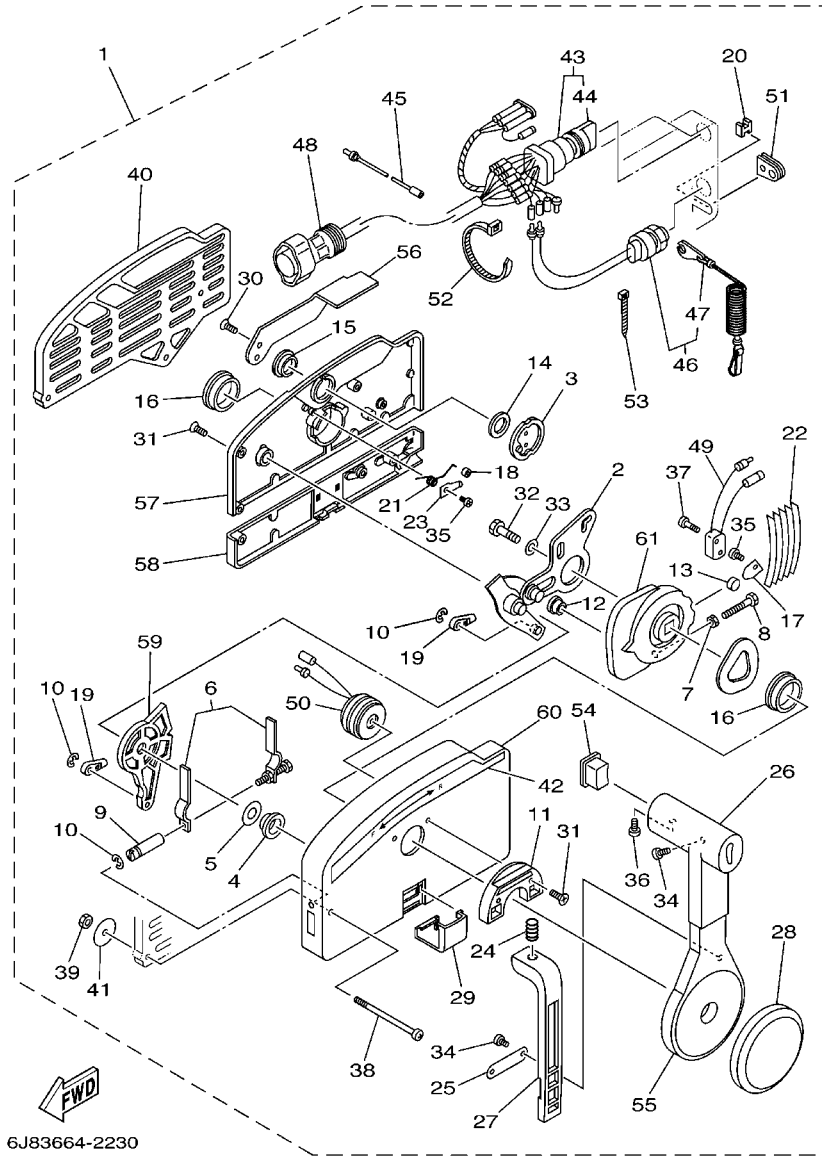
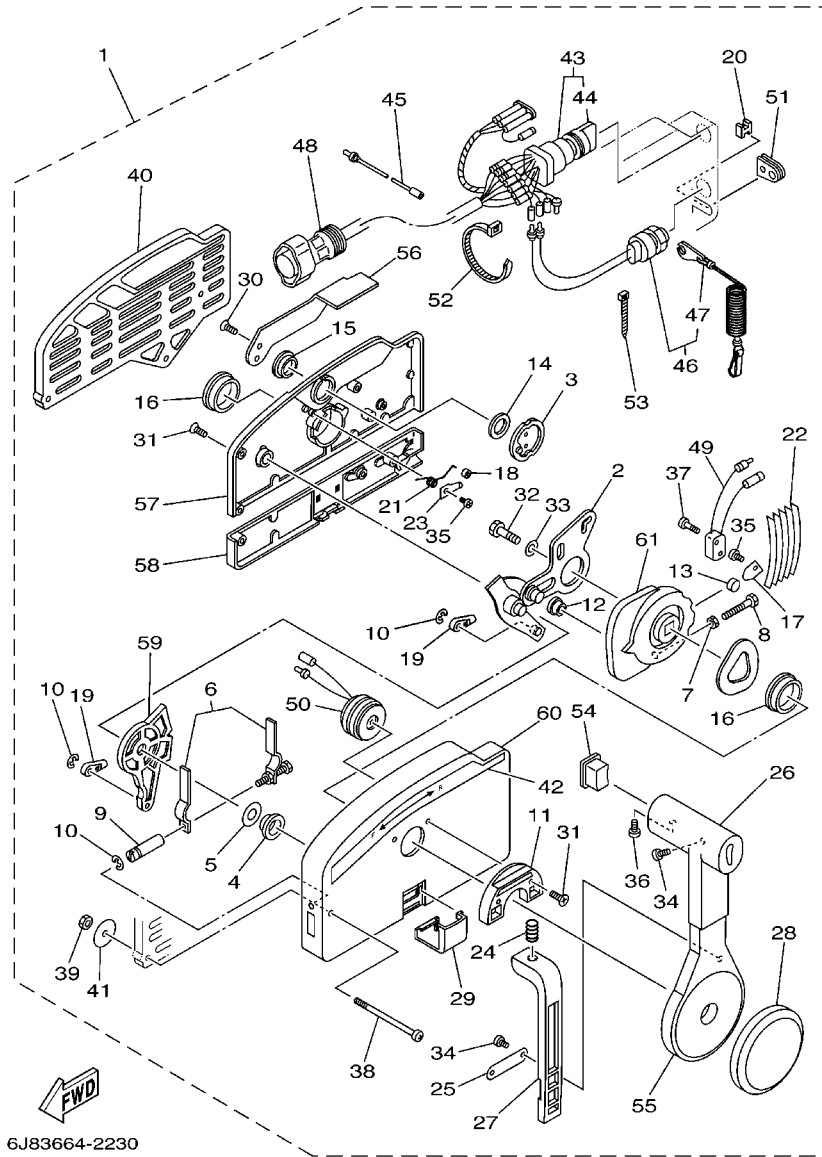

FIG. 29 REMOTE CONTROL ASSY CONTROL REMOTO COMPL

REF. NO.	PART NO. CODIGO Nº	DESCRIPTION DESCRIPCION	MHD	WHD	WD	REMARKS OBSERVACIONES
1	703-48230-15	REMOTE CONTROL ASSY (7P) CONTROL REMOTO COMPL. (7P)			1	AP WITHOUT PT/T SW. AP WITHOUT PT/T SW.
2	703-48261-11	.ARM, THROTTLE .BRAZO ACELERADOR			1	
3	703-48153-00	.SHAFT, FREE ACCEL. .EJE			1	
4	703-48235-00	.BUSHING .BUJE			1	
5	703-48268-00	.SPACER .ESPACIADOR 3			1	
6	703-48264-00	.FRICTION, THROTTLE .FRICCION DE ACELERADOR			1	
7	95380-05600	.NUT .TUERCA			1	
8	97380-05025	.BOLT .TORNILLO HEXAGONAL			1	
9	703-48265-00	.SHAFT, FRICTION .EJE FRICCION			1	
10	93430-06024	.CIRCLIP .SEGURO			3	
11	703-48245-00	.PLATE, LOCK .PLACA CERRADURA			1	
12	703-48252-00	.ROLLER, CAM .RODILLO LEVA			1	
13	701-48248-00	.ROLLER, FREE ACCEL. .RODILLO ACELERADOR LIBRE			1	
14	703-48198-00	.WASHER, WAVE .RONDANA ONDULADA 3			1	
15	703-48243-00	.BUSHING .BUJE 3			1	
16	703-48236-00	.BUSHING 1 .BUJE			2	
17	703-48189-00	.RETAINER .RETENEDOR			1	
18	703-48234-00	.ROLLER, DETENT .RODILLO			1	
19	703-48345-01	.CABLE END, REMOTE CONTROL 2 .TERMINAL CABLE DE CONTROL REM			2	
20	703-48358-00	.ANCHOR, CABLE .ABRAZADERA CABLE			1	
21	703-48244-00	.SPRING, FREE ACCEL. .RESORTE ACELERADOR LIBRE			1	
22	703-48238-00	.SPRING, DETENT .RESORTE			5	
23	703-48246-00	.SPACER .ESPACIADOR			1	
24	703-48227-00	.SPRING, NEUTRAL LOCK .RESORTE DE SEGURO			1	
25	703-48226-00	.PLATE, STOPPER .PLACA RETEN			1	
26	703-48222-00	.GRIP, CONTROL LEVER .MANGO DE PALANCA CONTROL			1	SINGLE SINGLE
27	703-48223-00	.LOCK, NEUTRAL .CERRADURA NEUTRO			1	



6J83664-2230

FIG. 29 REMOTE CONTROL ASSY

CONTROL REMOTO COMPL

REF. NO.	PART NO. CODIGO Nº	DESCRIPTION DESCRIPCION	MHD	WHD	WD	REMARKS OBSERVACIONES
28	703-48225-00	.COVER .CUBIERTA			1	
29	703-48219-00	.COVER, LEAD .CUBIERTA			1	
30	703-48281-00	.SCREW .TORNILLO 1			2	
31	703-48282-00	.SCREW .TORNILLO 2			7	
32	97380-08030	.BOLT .TORNILLO HEXAGONAL			1	
33	92990-08600	.WASHER, PLATE .ARANDELA PLANA			1	
34	98580-04010	.SCREW, PAN HEAD .TORNILLO DE CABEZA CRUZADA			3	
35	98580-04006	.SCREW, PAN HEAD .TORNILLO DE CABEZA CRUZADA			2	
36	98580-05010	.SCREW, PAN HEAD .TORNILLO DE CABEZA CRUZADA			1	
37	98580-03015	.SCREW, PAN HEAD .TORNILLO DE CABEZA CRUZADA			2	
38	703-48291-10	.SCREW (M6) .TORNILLO (M6)			3	
39	95380-06600	.NUT, HEXAGON .TUERCA			3	
40	703-48293-10	.SPACER, REMOTE CONTROL .ESPACIADOR			1	SINGLE SINGLE
41	701-48287-00	.WASHER .ARANDELA			3	
42	703-48215-00	.GRAPHIC .CALCOMANIA 1			1	
43	703-82510-33	.MAIN SWITCH ASSY .CONJUNTO DE LLAVE IGNICION			1	
44	703-82577-00	..CAP, KEY ..TAPA			1	
45	703-82531-00	.WIRE, LEAD .CABLE CONDUCTOR			1	
46	688-82575-01	.ENGINE STOP SWITCH ASSY .INTERRUPTOR DE PARADA COMPL			1	
47	682-82556-00	..LANYARD, STOP SWITCH ..RETENER			1	
48	688-82586-21	.EXTENSION, WIRE HARNESS .EXTENSION, CONJ. DE CABLES			1	L:5M (7P) L:5M (7P)
49	703-82540-00	.NEUTRAL SWITCH ASSY .INTERRUPTOR NEUTRAL COMPL			1	
50	703-83383-02	.BUZZER .ZUMBADOR			1	
51	703-48284-00	.GROMMET .TAPON 1			1	
52	703-82591-00	.BAND .BANDA			1	
53	703-82592-00	.BAND .BANDA			1	
54	703-48224-00	.COVER, CONTROL LEVER .CUBIERTA DE PALANCA CONTROL			1	WITHOUT PT/T SW. WITHOUT PT/T SW.

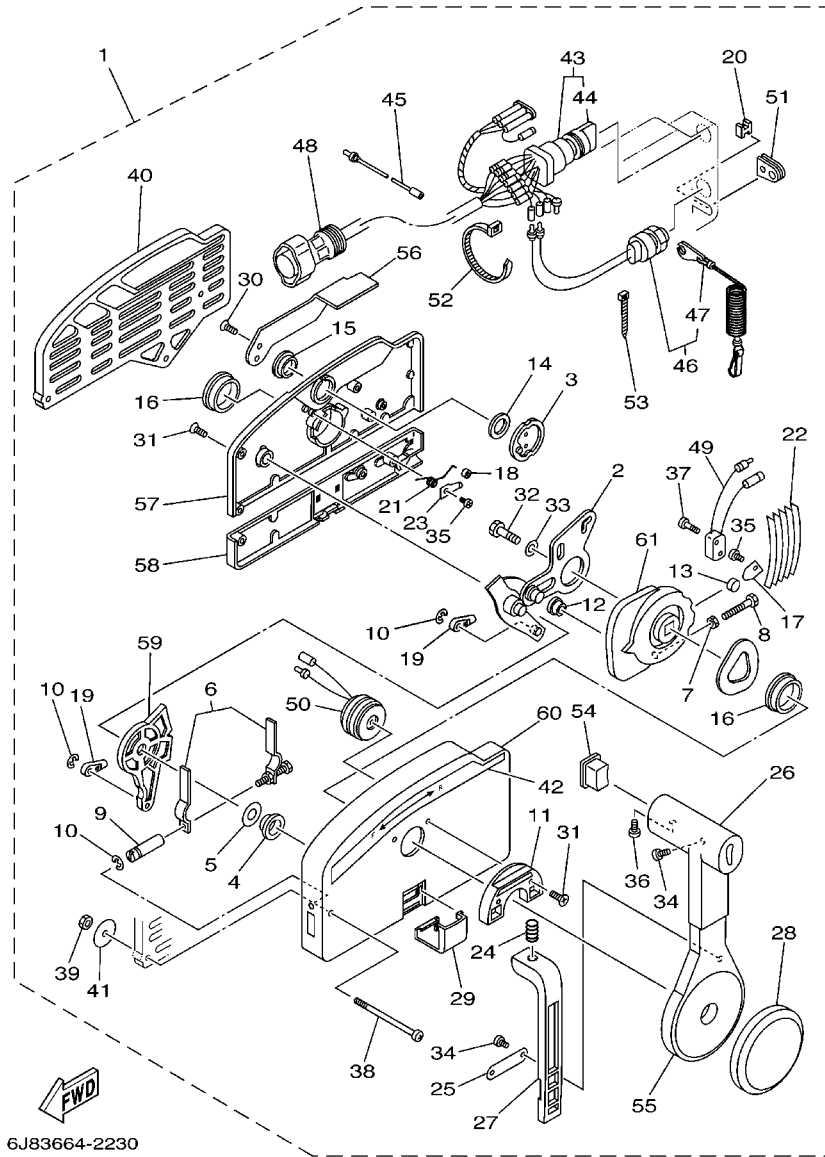

6J83664-2230

FIG. 29 REMOTE CONTROL ASSY

CONTROL REMOTO COMPL

REF. NO.	PART NO. CODIGO Nº	DESCRIPTION DESCRIPCION	MHD	WHD	WD	REMARKS OBSERVACIONES
55	703-48221-00	.LEVER, CONTROL .PALANCA CONTROL			1	
56	703-48152-00	.KNOB, FREE ACCEL. .PERILLA			1	
57	703-48212-00	.BACK PLATE 1 .PLACA TRASERA 1			1	
58	703-48213-00	.BACK PLATE 2 .PLACA TRASERA 2			1	
59	703-48271-00	.ARM, SHIFT .BRAZO CAMBIADOR			1	
60	703-48211-01	.HOUSING,1 .CAJA			1	
61	703-48232-00	.GEAR .ENGRANAJE 1			1	

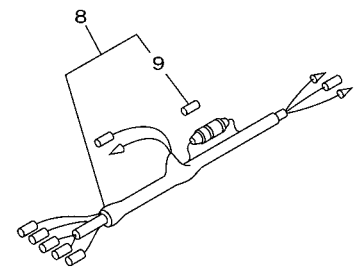
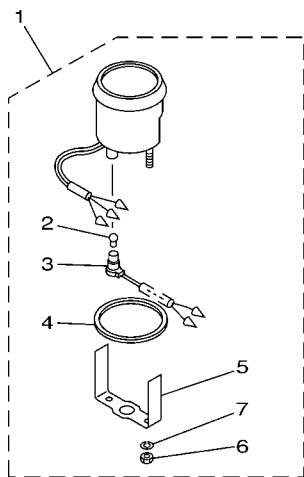

6964200-D310

FIG. 30 METER

MEDIDOR

REF. NO.	PART NO. CODIGO Nº	DESCRIPTION DESCRIPCION	MHD	WHD	WD	REMARKS OBSERVACIONES
1	6Y7-83540-20	TACHOMETER ASSY TACOMETRO COMPLETO			1	AP FOR CHN AP FOR CHN
2	6Y5-83517-00	.BULB (12V-1.7W, T10) .BOMBILLA (12V-1.7W, T10)			1	
3	6Y5-83536-40	.SOCKET, METER .ENCASTRE DE MEDIDOR			1	
4	6Y5-83523-00	.DAMPER .AMORTIGUADOR			1	
5	6Y5-83514-00	.PLATE, FITTING .PLACA ACCESORIA			1	
6	95380-05600	.NUT .TUERCA			2	
7	92990-05100	.WASHER, SPRING .ARANDELA PLANA			2	
8	6Y5-83553-00	WIRE, LEAD (L=2.5M) CABLE CONDUCTOR (L=2.5M)			1	AP FOR CHN AP FOR CHN
9	1E6-82151-00	.FUSE (10A) .FUSIBLE (10A)			1	

FIG. 31 REPAIR KIT 1

ESTUCHE REPARATION 1

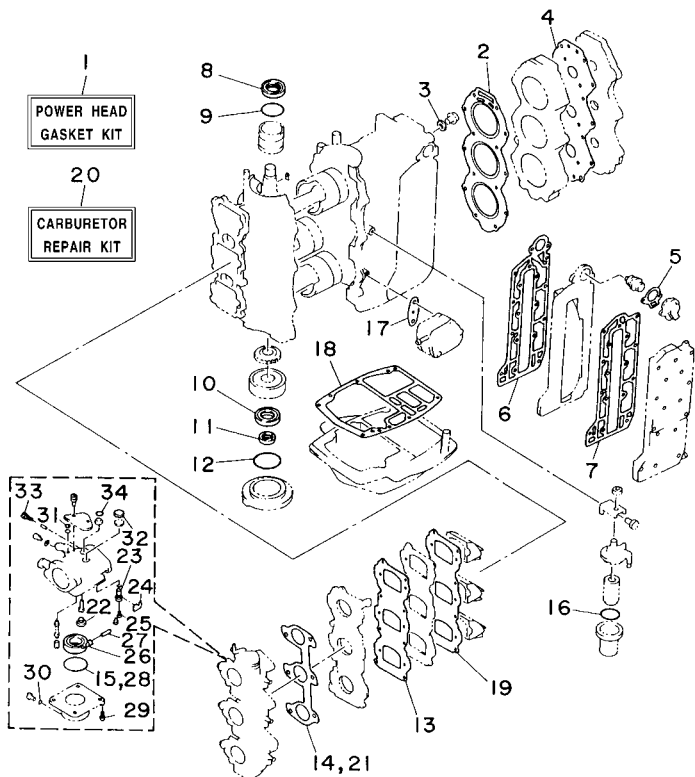

REF. NO.	PART NO. CODIGO Nº	DESCRIPTION DESCRIPCION	MHD	WHD	WD	REMARKS OBSERVACIONES
1	69D-W0001-00	POWER HEAD GASKET KIT JUEGO DE EMPAQUE DE MOTOR	1	1	1	
2	6H3-11181-A1	.GASKET, CYLINDER HEAD 1 .JUNTA, DE CULATA 1	1	1	1	
3	90430-14115	.GASKET .JUNTA	1	1	1	
4	6H3-11193-A1	.GASKET, HEAD COVER 1 .EMPAQUE	1	1	1	
5	6H3-12414-A1	.GASKET, COVER .EMPAQUE	1	1	1	
6	6H3-41112-A0	.GASKET, EXHAUST INNER COVER .EMPAQUE	1	1	1	
7	6H3-41114-A0	.GASKET, EXHAUST OUTER COVER .EMPAQUE	1	1	1	
8	93102-36M24	.OIL SEAL .SELLO ACEITE	1	1	1	
9	93210-46M16	.O-RING .ANILLO O	1	1	1	
10	93102-30009	.OIL SEAL .SELLO ACEITE	1	1	1	
11	93106-18001	.OIL SEAL .SELLO ACEITE	1	1	1	
12	93210-65M50	.O-RING .ANILLO O	1	1	1	
13	6H3-13621-A1	.GASKET, VALVE SEAT .JUNTA, DE VALV.DE EMPAQUE	1	1	1	
14	6H3-14198-A1	.GASKET .EMPAQUE	1	1	1	
15	6G1-14984-00	.O-RING .EMPAQUE CAMARA DE BOIA	3	3	3	
16	61A-24564-00	.O-RING .ANILLO O	1	1	1	
17	650-24431-A0	.GASKET, FUEL PUMP 1 .EMPAQUE BOMBA COMBUST 1	1	1	1	
18	6H3-45113-A0	.GASKET, UPPER CASING .EMPAQUE	1	1	1	
19	6H3-13622-A1	.GASKET, VALVE SEAT .EMPAQUE DE ASIENTO VALVULA	1	1	1	
20	6H3-W0093-02	CARBURETOR REPAIR KIT KIT REPARACION CARBURADOR	1	1	1	
21	6H3-14198-A1	.GASKET .EMPAQUE	1	1	1	
22	676-14966-00	.CAP .TAPA	3	3	3	
23	6H3-14590-01	.NEEDLE VALVE ASSY .VALVULA DE AGUJA COMPLETA	3	3	3	
24	663-14159-00	.CLIP .PRESILLA	3	3	3	
25	676-14186-00	.PIN, FLOAT .PASADOR DE LA BOYA	3	3	3	
26	6G1-14985-00	.FLOAT .BOIA	3	3	3	
27	688-14548-00	.PIN, FLOAT ARM .PASADOR DE BRAZO DE BOIA	3	3	3	



6H20010-4180

FIG. 31 REPAIR KIT 1

ESTUCHE REPARATION 1

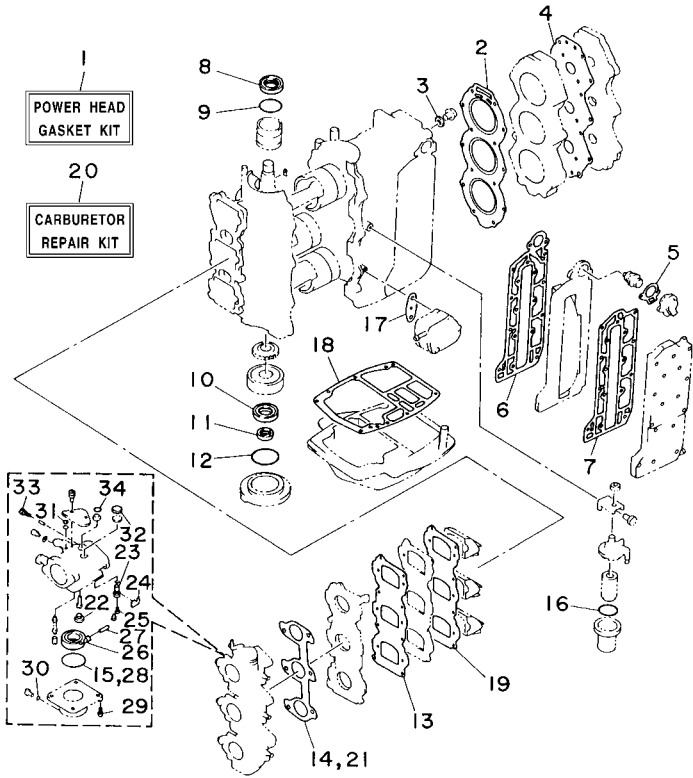

REF. NO.	PART NO. CODIGO Nº	DESCRIPTION DESCRIPCION	MHD	WHD	WD	REMARKS OBSERVACIONES
28	6G1-14984-00	.O-RING .EMPAQUE CAMARA DE BOIA	3	3	3	
29	97980-04114	.SCREW, WITH WASHER .TORNILLO, CON ARANDELA	3	3	3	
30	93210-04230	.O-RING .ANILLO O	3	3	3	
31	663-14126-00	.GASKET .EMPAQUE	3	3	3	
32	688-14126-00	.GASKET .EMPAQUE	3	3	3	
33	692-14923-00	.SCREW, PILOT .TORNILLO DE AJUSTE	3	3	3	
34	93210-15M52	.O-RING .ANILLO O	3	3	3	

FIG. 32 REPAIR KIT 2

ESTUCHE REPARATION 2

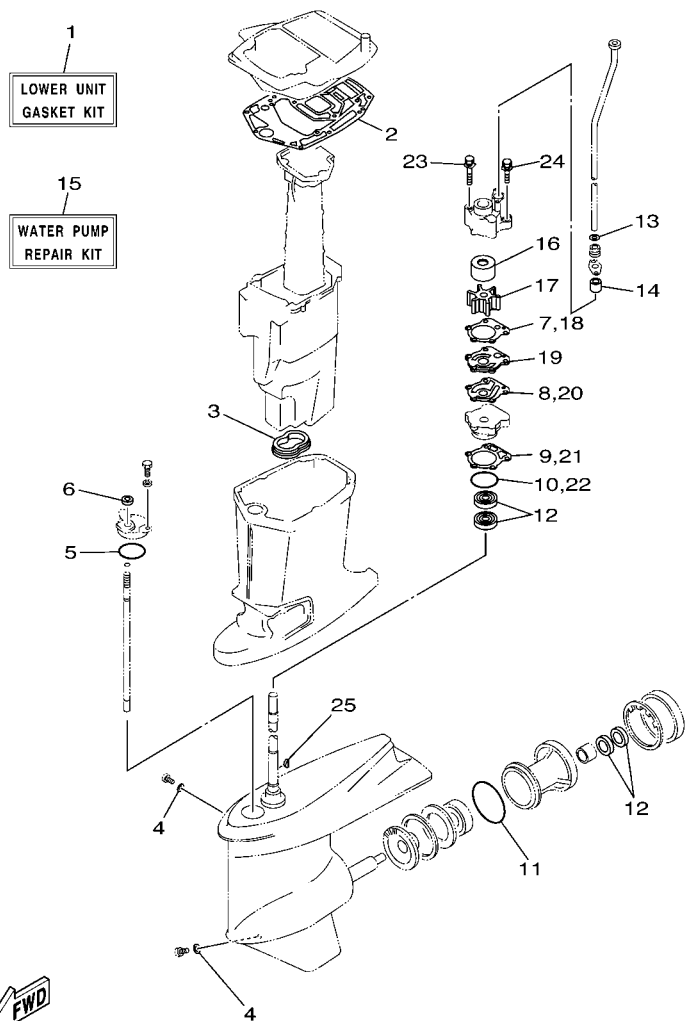

69D0100-1230



REF. NO.	PART NO. CODIGO Nº	DESCRIPTION DESCRIPCION	MHD	WHD	WD	REMARKS OBSERVACIONES
1	69D-W0001-20	LOWER UNIT GASKET KIT JUEGO DE EMPAQUE UNIDAD INFER.	1	1	1	
2	6H3-45114-A1	.GASKET, UPPER CASING .EMPAQUE	1	1	1	
3	6H3-45123-00	.GASKET, MUFFLER .EMPAQUE SILENCIADOR	1	1	1	
4	90430-08020	.GASKET .JUNTA	2	2	2	
5	93210-49046	.O-RING .ANILLO O	1	1	1	
6	93106-09014	.OIL SEAL .SELLO ACEITE	1	1	1	
7	688-44315-A0	.GASKET, WATER PUMP .EMPAQUE	1	1	1	
8	688-44324-A0	.GASKET, CARTRIDGE .EMPAQUE	1	1	1	
9	688-44316-A0	.GASKET, WATER PUMP .EMPAQUE	1	1	1	
10	93210-46044	.O-RING .ANILLO O	1	1	1	
11	93210-85M97	.O-RING .ANILLO O	1	1	1	
12	93101-25M03	.OIL SEAL .SELLO ACEITE	4	4	4	
13	90430-12072	.GASKET .JUNTA	1	1	1	
14	663-44366-00	.DAMPER, WATER SEAL .GOMA DEL SELLO DE AGUA	1	1	1	
15	69D-W0078-00	WATER PUMP REPAIR KIT ESTUCHE REPARACION BOMBA AGUA	1	1	1	
16	69D-44322-00	.INSERT, CARTRIDGE .CARTUCHO	1	1	1	
17	688-44352-03	.IMPELLER .IMPULSOR	1	1	1	
18	688-44315-A0	.GASKET, WATER PUMP .EMPAQUE	1	1	1	
19	688-44323-40	.OUTER PLATE, CARTRIDGE .PLACA EXTERIOR DEL CARTUCHO	1	1	1	
20	688-44324-A0	.GASKET, CARTRIDGE .EMPAQUE	1	1	1	
21	688-44316-A0	.GASKET, WATER PUMP .EMPAQUE	1	1	1	
22	93210-46044	.O-RING .ANILLO O	1	1	1	
23	90119-08M16	.BOLT, WITH WASHER .TORNILLO CON ARANDELA	2	2	2	
24	90119-08M13	.BOLT, WITH WASHER .TORNILLO CON ARANDELA	2	2	2	
25	90280-04M04	.KEY, WOODRUFF .CUNA WOODRUFF	1	1	1	

NUMERICAL INDEX
INDICE NUMERICO

PART NO. CODIGO N°	REF. NO.	PART NO. CODIGO N°	REF. NO.	PART NO. CODIGO N°	REF. NO.	PART NO. CODIGO N°	REF. NO.	PART NO. CODIGO N°	REF. NO.	PART NO. CODIGO N°	REF. NO.
6H3-11111-01-1S	2 - 24	663-14159-00	31 - 24	692-15711-00	7 - 2	650-24351-01	26 - 12	6H3-41612-10	8 - 16	6H4-42726-00	15 - 24
6K5-11119-01	2 - 20	676-14186-00	5 - 10	663-15713-00	7 - 5	61J-24360-00	26 - 10	6K5-41618-00	8 - 17	6H3-42727-00	15 - 19
6H3-11181-A1	2 - 25		31 - 25	663-15714-01	7 - 6	688-24378-00	6 - 43	6H3-41631-00	17 - 2	6H3-42738-01-5B	15 - 16
	31 - 2	6H3-14198-A1	4 - 11	663-15715-00	7 - 12	692-24410-00	6 - 26	6H3-41632-00	17 - 8	6H3-42741-01-4D	15 - 28
6H3-11191-00-1S	2 - 26		31 - 14	663-15716-01	7 - 13	663-24411-00	6 - 31	6H3-41633-00	17 - 11	69M-42758-00	13 - 5
6H3-11193-A1	2 - 27	6K5-14301-03	5 - 1	663-15719-00	7 - 15	692-24411-00	6 - 28	679-41636-00	17 - 15	6H3-42768-00	15 - 23
	31 - 4	6K5-14302-03	5 - 2	6K5-15723-00	7 - 46	6A0-24412-02	6 - 37	663-42111-02-4D	16 - 1	6H3-42771-01-4D	15 - 29
6H3-11325-01	2 - 16	6K5-14303-03	5 - 3	663-15726-01	7 - 10	6A0-24413-00	6 - 27	692-42111-21-4D	16 - 1	6G5-42791-00	15 - 35
6H3-11327-00-1S	2 - 17	6A0-14325-00	6 - 36	663-15734-01	7 - 14	6A0-24421-01	6 - 35	663-42115-00	16 - 10	6G5-42791-10	15 - 35
6H3-11328-00	2 - 18	6H3-14413-10	4 - 18	663-15735-01	7 - 50	650-24431-A0	6 - 38	692-42115-00	16 - 10	6H3-42813-00	15 - 7
650-11370-01	2 - 4	6H3-14440-02	4 - 19	663-15736-00	7 - 55		31 - 17	664-42119-00	16 - 2	6H3-42815-01-4D	15 - 3
688-11370-01	2 - 3	6H3-14457-01	4 - 20	663-15739-00	7 - 4	648-24434-01	6 - 29	692-42121-02-4D	16 - 20	6H3-42816-00	15 - 9
6K5-11401-00	3 - 8	624-14485-00	2 - 5	663-15741-02	7 - 8	648-24435-02	6 - 32	663-42126-01	16 - 56	6H3-42817-01-4D	15 - 4
6K5-11402-00	3 - 15	6K5-14488-00	4 - 24	663-15744-00	7 - 11	61A-24469-00	6 - 13	663-42133-01	16 - 14	6H3-42818-00	15 - 10
6K5-11403-00	3 - 22	63V-14523-00	5 - 29	663-15752-00	7 - 18	61A-24521-00	6 - 8	663-42134-03-94	16 - 15	63D-43111-01-4D	20 - 1
6K5-11412-00	3 - 9	663-14527-00	5 - 20	663-15753-00	7 - 19	65L-24531-01	6 - 9	663-42135-01	16 - 13	697-43111-05-4D	18 - 1
6K5-11422-00	3 - 10	688-14527-00	5 - 22	663-15754-00	7 - 9	60H-24558-00	6 - 14	6K5-42137-00	16 - 4	688-43111-13-4D	18 - 1
6H3-11432-00	3 - 17	6H2-14527-01	5 - 23	689-15755-01	7 - 23	61A-24560-04	6 - 7	663-42138-00	16 - 11	63D-43112-01-4D	20 - 8
6K5-11442-00	3 - 24	688-14548-00	5 - 13	6K5-15758-01-94	7 - 40	61A-24563-00	6 - 12	6F6-42177-A0	16 - 3	697-43112-03-4D	18 - 9
6H3-11515-00	3 - 34		31 - 27	6K5-15761-00	1 - 14	61A-24564-00	6 - 10	6H3-42191-01	16 - 41	688-43112-12-4D	18 - 9
6K5-11601-02	3 - 38	679-14555-00	5 - 26	6K5-15762-00	7 - 44		31 - 16	6H3-42192-00	16 - 43	648-43114-01	18 - 12
6K5-11601-12	3 - 38	6H2-14578-00	5 - 31	663-15764-00	7 - 7	69D-24566-01	6 - 18	6H3-42510-03-4D	21 - 1		20 - 11
6K5-11601-22	3 - 38	6H3-14578-00	5 - 32	6K5-15770-01	7 - 47	61A-24577-01	6 - 11	69D-42510-11-4D	21 - 1	663-43116-01	18 - 13
6K5-11631-03-95	3 - 37	6H3-14590-01	5 - 8	6K5-15771-00-94	7 - 33	6YJ-24610-01	26 - 2	69D-42515-00	16 - 51		20 - 12
6H3-11633-00	3 - 39		31 - 23	6K5-15772-00-94	7 - 36	692-26301-03	16 - 19	663-42518-00	16 - 47	663-43118-01-4D	18 - 15
688-11634-10	3 - 40	6K5-14592-00	5 - 27	648-15773-00	7 - 3	6A1-28176-00	15 - 36	67G-42528-00	16 - 48		20 - 14
6K5-11635-03	3 - 37	6H3-14711-01-5B	22 - 14	6K5-15773-01	7 - 39	61H-2819R-31	6 - 48	69D-42610-00-4D	1 - 1	688-43124-02	19 - 5
6K5-11636-03	3 - 37	69D-14711-10-5B	22 - 14	6K5-15774-00	7 - 59	6H3-41111-01-1S	2 - 36	69D-42610-H0-4D	1 - 1	69D-43126-00	20 - 40
6K5-11651-00	3 - 11	6H3-14711-11-5B	22 - 14	6F5-15779-02	7 - 25	6H3-41112-A0	2 - 37	6H3-42613-01-4D	1 - 10	6E5-43126-02	18 - 38
6K5-11681-00	3 - 12	6H3-14737-00	22 - 20	697-15789-00	7 - 45		31 - 6	6H3-42615-00	1 - 13	63D-43128-01-4D	20 - 15
6H3-12411-11	2 - 31	6H3-14737-10	22 - 20	663-15791-00	7 - 20	6H3-41113-02-1S	2 - 38	69D-42616-00	1 - 19	688-43128-01-4D	19 - 1
688-12412-00	2 - 32	692-14923-00	5 - 25	663-15794-00	7 - 52	6H3-41114-A0	2 - 39	69D-42620-00-4D	1 - 10	697-43128-01-4D	19 - 1
6H3-12413-00-1S	2 - 33		31 - 33	6YJ-24167-00	26 - 7		31 - 7	6H3-42647-00-94	1 - 2	63D-43131-01	20 - 19
6H3-12414-A1	2 - 34	676-14943-34	5 - 5	6YJ-24201-00	26 - 1	69D-41131-00-5B	22 - 11	6H3-42649-00-94	1 - 3	688-43131-03	18 - 21
	31 - 5	6K5-14945-36	5 - 35	6YJ-24201-10	26 - 1	6H2-41131-00-5B	22 - 11	6H3-42652-00	1 - 5	6G5-43144-00	18 - 43
677-13437-0B	1 - 17	6H2-14947-02	5 - 4	6YJ-24260-00	26 - 3	6H3-41137-01-94	22 - 5	663-42662-00	1 - 4		20 - 50
6H2-13610-00	4 - 1	6H4-14948-15	5 - 6	6Y1-24260-12	26 - 3	6H3-41213-01	17 - 22	69D-42677-H0	1 - 18	6E5-43145-01	27 - 9
6H3-13621-A1	4 - 6	6K5-14950-21	5 - 36	6Y1-24268-00	26 - 6	6H3-41217-00	4 - 12	6K5-42678-H0	1 - 16	6G5-43145-01	18 - 25
	31 - 13	676-14966-00	5 - 7	6G1-24304-02	6 - 1	662-41237-01	17 - 14	6H3-42711-06-4D	15 - 1		20 - 23
6H3-13622-A1	4 - 8		31 - 22	6G1-24305-05	26 - 13	682-41237-50	17 - 19	6H3-42711-15-4D	15 - 1	6G5-43148-00	18 - 29
	31 - 19	6H2-14980-00	5 - 15	6Y1-24305-06	26 - 15	6H3-41238-00	17 - 1	648-42715-00	17 - 27		20 - 28
6H3-13624-00-94	4 - 7	6G1-14984-00	5 - 14	61J-24306-04	26 - 8	6H3-41257-00	4 - 13	6H3-42716-02	15 - 12	697-43160-00	18 - 34
6H3-13641-03-94	4 - 5		31 - 15	69D-24311-00	6 - 4	6J8-41262-00	19 - 12	6K5-42717-00	15 - 13	688-43160-01	18 - 34
663-14126-00	5 - 19	6G1-14985-00	5 - 12	69D-24312-00	6 - 23	661-41262-02	4 - 14	6H3-42718-00	15 - 34		20 - 31
	31 - 31		31 - 26	663-24312-01	2 - 41	6H3-41271-00	4 - 15	6E5-42724-00	15 - 14	688-43165-00	18 - 35
688-14126-00	5 - 21	6H3-14992-00	5 - 17	6H3-24313-00	6 - 44	689-41273-00	4 - 16	6H3-42725-00	15 - 15		20 - 32
	31 - 32	69D-15100-00-1S	2 - 2	6H3-24314-00	6 - 46	6H4-41611-00	8 - 12	6K5-42725-00	15 - 15	697-43170-03-4D	19 - 2
663-14159-00	5 - 9	6H3-15359-00-94	3 - 1	6Y1-24329-00	26 - 5	6H3-41612-00	8 - 13	6H3-42725-20	15 - 15	688-43170-04-4D	19 - 2

NUMERICAL INDEX
INDICE NUMERICO

PART NO. CODIGO N°	REF. NO.	PART NO. CODIGO N°	REF. NO.	PART NO. CODIGO N°	REF. NO.	PART NO. CODIGO N°	REF. NO.	PART NO. CODIGO N°	REF. NO.	PART NO. CODIGO N°	REF. NO.
69D-43170-10-4D	20 - 35	688-44323-40	23 - 31	69D-45300-00-4D	23 - 1	688-45577-01	23 - 62	6E5-45954-00-EL	25 - 18	703-48293-10	29 - 40
6H5-43181-03	20 - 24		24 - 30	69D-45300-10-4D	23 - 1		24 - 53	6E5-45956-00-EL	25 - 18	701-48320-20	28 - 2
688-43181-04	18 - 26		32 - 19	69D-45300-20-4D	23 - 1	688-45577-10	23 - 62	688-45970-03-98	25 - 18	701-48320-50	28 - 2
688-43181-10	18 - 26	688-44324-A0	23 - 32	69D-45300-40-4D	24 - 1		24 - 53	688-45972-02-98	25 - 18	700-48339-00	16 - 44
6H5-43185-03	20 - 25		24 - 31	6H1-45301-03-4D	23 - 2	688-45577-20	23 - 62	688-45974-02-98	25 - 18	663-48344-00	17 - 17
688-43185-04	18 - 27		32 - 8	688-45311-06-4D	24 - 2		24 - 53	688-45976-01-98	25 - 18	703-48345-01	29 - 19
688-43185-10	18 - 27	688-44341-01-94	23 - 27	688-45321-00	23 - 16	688-45577-30	23 - 62	688-45978-60-98	25 - 18	703-48358-00	29 - 20
688-43186-00	19 - 10		24 - 26		24 - 16		24 - 53	688-45987-01	25 - 13	6H3-48511-51-4D	21 - 24
6H1-43311-02-4D	18 - 18	688-44352-03	23 - 25	688-45331-00-94	23 - 60	688-45577-40	23 - 62	67F-45997-00	25 - 14	6H3-48538-00	17 - 41
697-43311-03-4D	18 - 18		24 - 24		24 - 51		24 - 53	703-48152-00	29 - 56	688-61350-10	27 - 1
69D-43311-11-4D	20 - 16		32 - 17	688-45341-10	23 - 10	688-45577-50	23 - 62	703-48153-00	29 - 3	688-61351-10	27 - 2
663-43318-00	18 - 33	69D-44361-00	25 - 2		24 - 10		24 - 53	703-48189-00	29 - 17	6E5-61355-00	27 - 8
682-43318-01	19 - 9	69D-44361-10	25 - 2	688-45371-02	25 - 8	688-45577-60	23 - 62	703-48198-00	29 - 14	6K5-81332-00	8 - 18
		69D-44361-20	25 - 2	688-45375-00	25 - 7		24 - 53	703-48211-01	29 - 60	6K5-81332-60	8 - 18
688-43616-00	19 - 13	663-44366-00	25 - 10	663-45376-00-94	25 - 6	688-45587-01	23 - 5	703-48212-00	29 - 57	6H3-81800-11	14 - 1
688-43631-00	19 - 3		32 - 14	6J8-45378-00	23 - 21		24 - 5	703-48213-00	29 - 58	6H3-81807-10	14 - 3
69D-43631-00	20 - 36	663-44367-00	25 - 1	688-45383-02	23 - 68	688-45587-10	23 - 5	703-48215-00	29 - 42	689-81809-11	14 - 7
688-43631-10	19 - 3	69D-44391-00	15 - 2		24 - 59		24 - 5	703-48219-00	29 - 29	6H3-81810-10	14 - 9
688-43651-00	19 - 15	688-44511-00-94	21 - 33	688-45384-00	23 - 69	688-45587-20	23 - 5	703-48221-00	29 - 55	689-81811-11	14 - 12
63D-43691-00	18 - 20	688-44514-00-94	21 - 26		24 - 60		24 - 5	703-48222-00	29 - 26	689-81812-11	14 - 11
		6H1-44526-00	18 - 3	69D-45501-00	23 - 36	688-45587-30	23 - 5	703-48223-00	29 - 27	689-81813-10	14 - 13
		6H3-44551-01-4D	21 - 7	69D-45501-10	23 - 36		24 - 5	703-48224-00	29 - 54	6H3-81820-11	14 - 14
697-44113-00	16 - 28	69D-44551-10-4D	21 - 7		24 - 35	688-45587-40	23 - 5	703-48225-00	29 - 28	689-81826-10	14 - 15
6H3-44117-00-94	17 - 30	6H3-44552-03-94	21 - 16	69D-45501-20	23 - 36		24 - 5	703-48226-00	29 - 25	6H3-81830-10	14 - 4
6J2-44117-01-94	17 - 30	6H3-44553-01-4D	21 - 21	688-45536-01	23 - 4	688-45587-50	23 - 5	703-48227-00	29 - 24	689-81831-00	14 - 5
6K5-44120-01	17 - 26	687-44555-00-94	21 - 9		24 - 4		24 - 5	703-48230-15	28 - 1	689-81840-11	14 - 10
6K5-44120-11	17 - 26	688-44555-00-94	21 - 9	6K5-45551-00	23 - 37	688-45587-60	23 - 5		29 - 1	689-81847-11	14 - 6
69D-44120-20	17 - 26	663-44575-00	21 - 14		24 - 36		24 - 5	703-48232-00	29 - 61	689-81850-12	14 - 8
6H3-44121-01	17 - 36	6H3-45111-01-4D	22 - 1	6K5-45560-00	23 - 39	688-45611-00	24 - 39	703-48234-00	29 - 18	689-81857-11	14 - 2
688-44122-00	17 - 39	6H3-45111-12-4D	22 - 1		24 - 38	6H1-45611-01	23 - 40	703-48235-00	29 - 4	6H3-81916-00	9 - 22
6H1-44144-00	23 - 55	6H3-45113-A0	22 - 7	688-45567-01	23 - 7	688-45631-01	24 - 40	703-48236-00	29 - 16	6H3-81922-00	9 - 10
6K5-44144-00	24 - 47		31 - 18		24 - 7	6H1-45631-01	23 - 41	703-48238-00	29 - 22	688-81950-10	10 - 6
663-44151-00	24 - 46	6H3-45114-A1	22 - 17	688-45567-10	23 - 7	688-45633-00	23 - 52	703-48243-00	29 - 15		11 - 5
6H1-44151-00	23 - 54		32 - 2		24 - 7		24 - 45	703-48244-00	29 - 21	6G1-81970-61	10 - 1
692-44159-01	16 - 32		32 - 2	688-45567-20	23 - 7	688-45634-00	24 - 41	703-48245-00	29 - 11		11 - 1
663-44173-00	16 - 33	6H3-45123-00	22 - 16		24 - 7	6H1-45634-02	23 - 43	703-48246-00	29 - 23	6H3-82105-01	10 - 11
6K5-44191-00	16 - 29		32 - 3	688-45567-30	23 - 7	688-45635-00	24 - 43	701-48248-00	29 - 13		11 - 10
688-44194-00	17 - 5	6H3-45127-00	22 - 15		24 - 7	6H1-45635-00	23 - 47	703-48252-00	29 - 12	6H3-82117-00	10 - 12
688-44311-01	23 - 22	6H3-45155-00	22 - 3	688-45567-40	23 - 7	6H1-45641-01	23 - 53	703-48261-11	29 - 2		11 - 11
		688-45211-01-4D	22 - 21		24 - 7	6H1-45668-00	23 - 46	703-48264-00	29 - 6	703-82119-00	15 - 25
688-44315-A0	23 - 24	696-45211-01-4D	22 - 21	688-45567-50	23 - 7	688-45930-02-98	25 - 18	703-48265-00	29 - 9	697-82127-01	21 - 23
		6H1-45214-00	23 - 12		24 - 7	688-45932-60-98	25 - 18	703-48268-00	29 - 5	688-82127-02	21 - 23
			24 - 12	688-45567-60	23 - 7	6E5-45941-00-EL	25 - 18	703-48271-00	29 - 59	63D-82148-00	20 - 9
688-44316-A0	23 - 30	6H1-45215-00	23 - 13		24 - 7	6E5-45943-00-EL	25 - 18	703-48281-00	29 - 30	6E5-82148-00	18 - 10
			24 - 13		24 - 7	6E5-45945-01-EL	25 - 18	703-48282-00	29 - 31	6H1-82148-00	20 - 5
		63D-45251-00	20 - 2	6H3-45571-00	23 - 59	6E5-45947-00-EL	25 - 18	703-48284-00	29 - 51	1E6-82151-00	30 - 9
		663-45251-00	18 - 2	6K5-45571-00	24 - 50	6E5-45949-00-EL	25 - 18	701-48287-00	29 - 41	6G1-82151-00	10 - 2
69D-44322-00	23 - 23		20 - 38	688-45576-00	23 - 63	6E5-45952-00-EL	25 - 18	703-48291-10	29 - 38		11 - 2
		6H1-45251-03	18 - 2		24 - 54						

NUMERICAL INDEX
INDICE NUMERICO

PART NO. CODIGO N°	REF. NO.	PART NO. CODIGO N°	REF. NO.	PART NO. CODIGO N°	REF. NO.	PART NO. CODIGO N°	REF. NO.	PART NO. CODIGO N°	REF. NO.	PART NO. CODIGO N°	REF. NO.
6H3-82164-00	10 - 9	6H3-85510-A1	8 - 2	90119-08M13	23 - 35	90201-10M63	27 - 7	90386-07M58	17 - 33	90464-04M12	9 - 15
	11 - 8	64J-85516-00	13 - 4		24 - 34	90201-11M22	21 - 30	90386-08032	16 - 9	90464-07M05	2 - 15
6A0-82317-00	7 - 41	663-85518-00	8 - 4		32 - 24	90201-12426	18 - 47	90386-10009	16 - 36	90464-07M10	9 - 21
63M-82370-01	9 - 28	6H3-85520-00	8 - 3	90119-08M16	23 - 34		20 - 54	90386-10025	20 - 27	90464-08M07	9 - 19
663-82370-01	9 - 28	6H3-85533-A0	8 - 6		24 - 33	90201-12537	16 - 25	90386-10M16	18 - 28		16 - 63
6G1-82370-21	9 - 28	6H3-85540-11	9 - 16		32 - 23	90201-12M16	21 - 10		20 - 26	90464-10M59	6 - 6
6H3-82510-20	12 - 1	6H3-85542-00-94	9 - 6	90119-08M32	7 - 30	90201-12M34	16 - 40	90386-12089	16 - 23	90464-12M17	9 - 20
703-82510-33	29 - 43	6K5-85550-10	8 - 1	90119-08M64	2 - 8	90201-13M19	21 - 12	90386-13M38	15 - 5	90464-15M11	10 - 10
697-8252E-02-4D	12 - 10	6K5-85550-A0	8 - 1	90119-08M79	22 - 8	90201-20417	3 - 42	90386-18M21	18 - 39		11 - 9
697-8252F-02-4D	12 - 11	6H3-85570-10	9 - 25	90119-08M81	22 - 4	90201-20M21	21 - 28		19 - 6		13 - 7
6K5-82531-00	9 - 3	6H3-86110-02	11 - 16	90119-08M85	22 - 24	90201-21M18	8 - 11	90386-18M35	18 - 40	90465-06M90	7 - 61
703-82531-00	29 - 45	6H3-86116-00	11 - 17	90119-08M86	22 - 24	90201-22M03	20 - 21		19 - 8		9 - 29
6H3-82540-00	12 - 5	69D-W0001-00	31 - 1	90119-08MA5	2 - 28	90201-22M67	18 - 23	90386-18M44	20 - 45	90465-08M83	6 - 25
703-82540-00	29 - 49	69D-W0001-20	32 - 1	90119-10005	2 - 7	90201-30M00	21 - 2	90386-18M63	19 - 7	90465-11M10	6 - 5
6H3-82554-00	12 - 6	688-W0004-00	4 - 2	90149-05095	7 - 54	90202-03M51	19 - 14	90386-22M15	18 - 22	90465-18147	11 - 22
663-82555-01	12 - 7	6K5-W0070-H0	1 - 15	90149-05M13	16 - 6	90202-07M07	17 - 38		20 - 20	90467-06016	2 - 10
682-82556-00	12 - 4	69D-W0078-00	32 - 15	90151-05M00	23 - 14	90202-12060	25 - 3	90386-30M60	21 - 6	90467-08004	2 - 42
	16 - 61	69D-W0090-01-1S	2 - 1		24 - 14	90202-12092	16 - 24	90386-30M77	21 - 4		6 - 42
	29 - 47	6H3-W0093-02	31 - 20	90152-06M01	18 - 5	90202-20M06	21 - 29	90386-30M78	21 - 3	90468-18008	7 - 56
688-82560-10	9 - 32	69D-W1140-01	3 - 7	90157-06M13	17 - 3	90202-25M04	21 - 11	90387-06M19	7 - 42		17 - 18
688-82575-01	29 - 46	692-W1571-02	7 - 1	90159-05M13	13 - 3	90206-10M04	17 - 23	90387-06M43	9 - 8	90480-09M12	15 - 20
6K5-82575-03	16 - 60	656-W2810-02	6 - 49	90170-09M03	27 - 5	90206-12054	16 - 26	90387-06M59	17 - 12	90480-13M24	9 - 9
688-82575-10	12 - 3	90101-06M27	16 - 57	90170-16M01	23 - 38	90206-13M10	15 - 6	90387-06M60	17 - 6	90480-19M06	25 - 11
676-82577-00	12 - 2	90101-08002	2 - 21		24 - 37	90209-06M05	4 - 22	90387-06M69	15 - 21	90501-10326	5 - 30
703-82577-00	29 - 44	90101-10M49	21 - 27	90170-18M10	20 - 47	90209-27011	3 - 13	90387-08M05	7 - 32	90501-10M21	18 - 30
6E3-8257H-00	15 - 37	90101-12M06	16 - 21	90170-20137	8 - 10	90243-04007	18 - 14	90387-10M02	18 - 32	90501-12082	17 - 29
689-8257Y-00	16 - 62	90101-12M65	18 - 45	90171-16011	25 - 16		20 - 13	90387-10M38	18 - 31	90501-12M48	23 - 48
688-82586-21	29 - 48		20 - 52	90175-06003	16 - 50	90249-06M19	18 - 31	90387-10M42	27 - 6	90501-14M08	21 - 19
69D-82590-00	10 - 5	90105-06M14	9 - 7	90179-06066	21 - 20		20 - 30	90387-12M30	16 - 39	90501-16233	24 - 42
6H3-82590-01	11 - 12	90105-10M67	25 - 9	90179-08M34	2 - 30	90250-07M02	23 - 51	90387-16003	20 - 41	90501-16M17	16 - 34
6K5-82590-10	10 - 5	90109-12M21	21 - 13	90183-02M03	23 - 50		24 - 44	90387-16004	20 - 42	90501-16M65	23 - 44
703-82591-00	29 - 52	90116-06M07	9 - 11	90185-05002	23 - 15	90254-03002	3 - 35	90389-25M00	25 - 15	90501-23215	16 - 8
703-82592-00	29 - 53	90116-08M69	2 - 29		24 - 15	90254-03003	16 - 12	90430-08020	23 - 11	90502-16M02	18 - 37
688-82594-00	10 - 13	90116-10M05	22 - 23	90185-08057	16 - 53	90266-06009	1 - 9		24 - 11		20 - 34
	11 - 15	90116-10M28	21 - 36	90185-09M01	27 - 4	90269-02M09	16 - 5		32 - 4	90502-20M03	18 - 37
703-83383-02	29 - 50	90116-10M31	22 - 23	90185-10051	16 - 38	90269-04M03	15 - 8	90430-12072	25 - 4	90506-08M23	7 - 51
6Y5-83504-20	13 - 1	90116-18M52	20 - 44		21 - 31	90280-04M04	23 - 26		32 - 13	90506-14M24	18 - 42
6Y5-83514-00	30 - 5	90119-06023	2 - 19	90185-12058	16 - 27		24 - 25	90430-14115	2 - 23		20 - 49
6Y5-83517-00	30 - 2	90119-06027	13 - 8	90185-22043	18 - 24		32 - 25		31 - 3	90508-12015	7 - 53
69D-83519-00	13 - 2	90119-06M09	15 - 11	90185-22M11	20 - 22	90280-05015	8 - 9	90445-07M02	2 - 11	90508-29M19	17 - 10
6Y5-83523-00	30 - 4	90119-06M29	18 - 4	90201-03313	23 - 49	90282-04010	23 - 67	90445-07M44	2 - 9	91490-16012	7 - 58
6Y5-83536-40	30 - 3	90119-06M61	15 - 22	90201-05652	5 - 28		24 - 58	90445-07M45	2 - 12	91490-20012	17 - 35
6Y7-83540-20	30 - 1	90119-06M65	7 - 43	90201-06068	6 - 17	90338-05M03	15 - 26	90445-07M82	2 - 13	91490-25012	16 - 46
6Y5-83553-00	30 - 8	90119-06M91	17 - 13	90201-06M05	13 - 6	90340-08002	23 - 9	90445-09072	6 - 41	91490-30025	18 - 32
6A1-83625-41	4 - 23	90119-06MA3	2 - 35	90201-06M31	17 - 9		24 - 9	90445-09220	6 - 45	91490-40025	25 - 17
6E0-83627-41	16 - 64		4 - 9	90201-10120	16 - 37	90340-14M00	2 - 22	90445-11M05	26 - 11	91690-30010	11 - 18
6H4-85411-00	9 - 4	90119-06MA5	2 - 40		21 - 25	90385-12M04	7 - 31	90445-11M06	26 - 9	91690-30012	18 - 36
6H4-85415-00	9 - 5	90119-08087	7 - 29	90201-10M20	27 - 3	90386-06088	16 - 42	90446-10M02	9 - 33		20 - 33

NUMERICAL INDEX
INDICE NUMERICO

PART NO. CODIGO N°	REF. NO.	PART NO. CODIGO N°	REF. NO.	PART NO. CODIGO N°	REF. NO.	PART NO. CODIGO N°	REF. NO.	PART NO. CODIGO N°	REF. NO.	PART NO. CODIGO N°	REF. NO.
91690-30020	18 - 30	92995-06600	18 - 8	93306-207U0	24 - 52	97013-06016	10 - 7	97880-06012	18 - 11		
	19 - 11		20 - 7	93306-306V1	3 - 33		11 - 6	97880-06025	9 - 17		
	20 - 29		23 - 20	93310-527W1	3 - 14		16 - 30		12 - 12		
92903-06100	7 - 16		24 - 20	93311-636U6	3 - 29	97013-06020	12 - 16	97885-05012	16 - 18		
	9 - 31	92995-08100	21 - 18	93315-325V1	23 - 3		17 - 31	97885-06008	16 - 17		
	12 - 15		22 - 10		24 - 3	97013-06025	7 - 34		20 - 10		
	16 - 31	92995-08600	16 - 55	93317-325U0	23 - 65		9 - 26	97885-06010	8 - 19		
92903-06200	9 - 57	92995-10100	18 - 17		24 - 56		14 - 18	97885-06012	8 - 14		
92903-06600	7 - 35	92995-12200	18 - 46	93332-000U3	23 - 6	97013-06030	8 - 7		9 - 23		
	8 - 8		20 - 53		24 - 6		12 - 14		12 - 8		
	9 - 2	92995-18600	20 - 46	93332-000UE	3 - 32	97013-06055	7 - 37	97885-06016	21 - 22		
	10 - 8	93101-25M03	23 - 28	93332-000W7	23 - 8	97013-08012	7 - 26	97885-06045	4 - 21		
	11 - 7		24 - 27		24 - 8	97013-08016	14 - 20	97902-05125	8 - 5		
	14 - 19		32 - 12	93410-16006	20 - 43	97013-08035	14 - 16	97980-04114	5 - 16		
	17 - 32	93102-30009	3 - 2	93410-18M02	18 - 41	97075-08025	21 - 17		31 - 29		
92903-08100	7 - 27		31 - 10	93410-28M06	21 - 8	97075-08030	22 - 12	97980-05310	5 - 24		
92903-08600	7 - 28	93102-36M24	3 - 30	93430-06024	29 - 10	97075-08035	21 - 34	98503-05028	6 - 33		
	14 - 17		31 - 8	93440-49M04	3 - 31		22 - 9	98580-03015	29 - 37		
92903-10600	16 - 7	93106-09014	23 - 18	93450-07M00	23 - 58	97080-06010	19 - 4	98580-04006	29 - 35		
92990-05100	6 - 34		24 - 18	93501-04M02	17 - 28	97080-06035	16 - 49	98580-04008	5 - 11		
	30 - 7		32 - 6	93503-16003	23 - 45	97095-06010	18 - 44	98580-04010	29 - 34		
92990-05600	4 - 4	93106-18001	3 - 3	93515-32M01	16 - 35		20 - 6	98580-05010	29 - 36		
	10 - 4		31 - 11	93603-12M11	23 - 42	97095-06012	7 - 48	98586-05016	26 - 4		
	11 - 4	93210-03261	11 - 21	93603-18M09	3 - 41	97095-06014	6 - 19	98680-06525	20 - 39		
92990-06100	9 - 14	93210-04228	5 - 34	93604-10M03	23 - 33	97095-06016	1 - 6	99001-08600	23 - 57		
	12 - 13	93210-04230	5 - 18		24 - 32		6 - 15		24 - 49		
92990-06200	9 - 13		31 - 30	93606-12019	22 - 2		15 - 17				
92990-06600	9 - 18	93210-07003	23 - 56		25 - 5		18 - 6				
	16 - 45		24 - 48	93608-12063	2 - 6		23 - 19				
92990-08200	17 - 34	93210-08287	26 - 14	93700-06M03	16 - 16		24 - 19				
92990-08600	16 - 52	93210-15M52	5 - 33		18 - 19	97095-06020	3 - 5				
	29 - 33		31 - 34		20 - 17		15 - 32				
92990-10100	22 - 26	93210-16275	27 - 10	94702-00160	2 - 43	97095-06025	6 - 2				
92990-10600	18 - 29	93210-29M94	21 - 5	94702-00247	2 - 43		15 - 30				
	22 - 27	93210-46044	23 - 29	95380-03600	6 - 30		17 - 7				
92990-12200	16 - 22		24 - 28	95380-05600	17 - 16		20 - 3				
92995-06100	1 - 7		32 - 10		29 - 7	97095-06040	6 - 39				
	6 - 16	93210-46M16	3 - 36		30 - 6	97095-06095	4 - 10				
	12 - 9		31 - 9	95380-06600	17 - 4	97095-08030	16 - 54				
	18 - 7	93210-49046	23 - 17		29 - 39	97095-10045	18 - 16				
	20 - 4		24 - 17	95380-06700	9 - 12	97303-06016	7 - 17				
92995-06600	1 - 8		32 - 5	95380-10600	22 - 25	97303-06025	7 - 22				
	3 - 6	93210-65M50	3 - 4	95380-12600	18 - 48	97380-05025	29 - 8				
	6 - 3		31 - 12		20 - 55	97380-08030	29 - 32				
	7 - 49	93210-85M97	23 - 64	95380-12800	21 - 15	97780-40512	25 - 12				
	8 - 15		24 - 55	97013-06012	7 - 60	97880-05016	4 - 3				
	9 - 24		32 - 11		9 - 1	97880-05025	10 - 3				
	15 - 18	93306-207U0	23 - 61		11 - 13		11 - 3				