



**PARTS
CATALOGUE
CATALOGO
DE REPUESTOS**

E25B'06 (69P6)

E30H'06 (60B6)

25B'06 (69R6)

30H'06 (69S6)

E25B/E30H
25B/30H
PARTS CATALOGUE
©2005 by Yamaha Motor Co., Ltd.
1st edition, September 2005
All rights reserved.
Any reprinting or unauthorized use
without the written permission of
Yamaha Motor Co., Ltd.
is expressly prohibited.
Printed in Japan.

E25B/E30H
25B/30H
CATALOGO DE REPUESTOS
©2005 por Yamaha Motor Co., Ltd.
1ª edición, septiembre 2005
Todos los derechos reservados.
Toda reproducción o uso no autorizado
sin el consentimiento escrito de
Yamaha Motor Co., Ltd.
quedan expresamente prohibidos
Impreso en Japón.

FOREWORD

This Parts Catalogue is related to the parts for the model(s) on the cover page. When you are ordering replacement parts, please refer to this Parts Catalogue and quote both part numbers and part names correctly.

1. Modifications or additions which have been made after the issue of the Parts Catalogue will be announced in the Parts News.
It is advisable that you make the necessary corrections to the Parts Catalogue according to the Parts News.

2. Abbreviations

The following abbreviations are used in this Parts Catalogue.

“UR” Use specified parts number.

“UN” Use as many as needed.

“AP” Alternate Parts

“LM” Locally Made (Parts need to be ordered locally)

“F#” Frame No. (Applicable machine No.)

“O/S” Over Size

3. The number of components for assembly

- Parts, which are to be supplied in an assembly, are listed with a dot (.) in front of the part name as shown below.
- The numeral appearing to the right of each component part indicates the quantity of parts for each assembly unit.

PART NO.	DESCRIPTION	Q'TY	REMARKS
2F5-83310-60	FRONT FLASHER LIGHT ASSY	2	
115-83311-60	.BULB (6V-18W)	1	

4. Applicable colours of graphics are represented in the “REMARKS” as shown below.

PART NO.	DESCRIPTION	Q'TY	REMARKS
2N4-24110-00-X5	FUEL TANK COMP.	2	MXR
3J1-24240-10	.GRAPHIC, FUEL TANK	1	FOR MXR

5. Note that the illustrations for reference in finding parts numbers are not to be used for assembling. When assembling, please use the applicable service manual.

6. The asterisk (*) before a reference number indicates modified items after the first edition.

7. Applicable Serial No.

Engine Serial No.

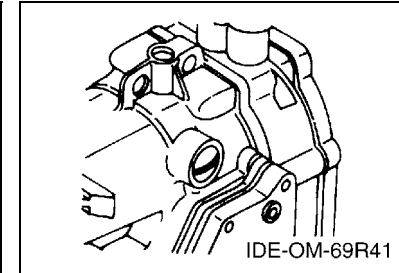
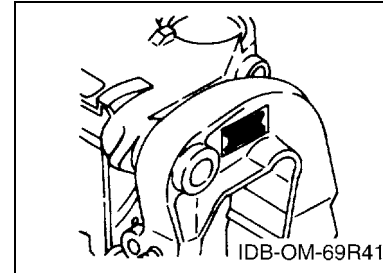

8. Applicable Engine Starting Serial No.

Model	Serial No.	Model	Serial No.
E25B	61RK-1014836	25B	61RK-1014836
E30H	61TK-1016671	30H	61TK-1016671

9. Applicable Colour Code

Abbreviation	Colour Name	Colour Code
DBNM2	DARK BLUIISH GRAY METALLIC 2	004D

10. Quantity Column Information

Column No.	Name Of Q'ty Column	Applicable Model
1	MH	E25BMH,E30HMH,25BMH,30HMH
2	WH	30HWH
3	W	25BW,30HW
4	WC	25BWC,30HWC

PROLOGO

Este catálogo de repuestos corresponde a las piezas para el o los modelos que figuran en la página de portada. Al formular el pedido de repuestos, se ruega citar este catálogo y especificar correctamente el número y el nombre de las piezas.

- Las modificaciones y agregados que se hayan realizado después de la edición de este Catálogo de Repuestos, serán anunciados en las Informaciones de Recambios. Es recomendable que se hagan las correcciones necesarias en el Catálogo de Repuestos de acuerdo con las Informaciones de Recambios.

2. Abreviaciones

En este. Catálogo de Repuestos se emplean las siguientes abreviaciones.

“UR” Usar el número de partes especificado

“UN” Usar la cantidad necesaria

“AP” Piezas sustitutivas

“LM” Fabricación local (Hay que pedir los repuestos en las cercanías)

“F#” N° de bastidor (N° aplicable a la máquina)

“O/S” Sobredimensionado

3. La cantidad de componentes para el montaje

- Los componentes, suministrados como conjunto, se describen con un punto (.) que precede al nombre del parte como se indica a continuación.
- La numeración que aparece a la derecha de cada descripción indica la cantidad de partes por cada unidad de conjunto.

CODIGO N°	DESCRIPCION	CANT.	OBSERVACIONES
2F5-83310-60	ENSAMBLAJE DE LA LUZ	2	
115-83311-60	.BOMBILLA (6V-18W)	1	

4. Los colores de los componentes se indican como sigue en la columna de “OBSERVACIONES”.

CODIGO N°	DESCRIPCION	CANT.	OBSERVACIONES
2N4-24110-00-X5	COMP. DEL TANQUE	2	MXR
3J1-24240-10	.GRAFICO, DEL TANQUE	1	PARA MXR

- Debe tenerse en cuenta que las ilustraciones sirven como guía para la búsqueda de los números de partes y no deben usarse para el montaje. Durante el montaje, se recomienda usar el manual de taller correspondiente.

- EL asterisco (*) antes del número de referencia indica los elementos modificados después de la primera edición.

7. Números de serie

N° de Serie del motor

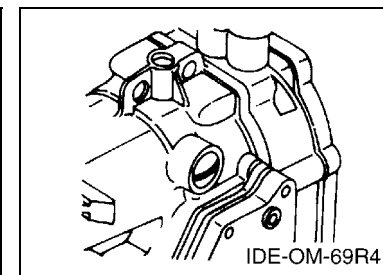
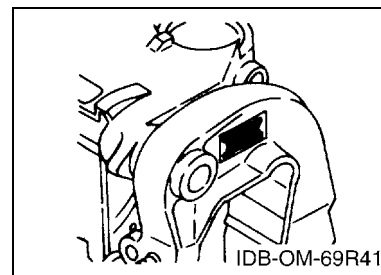

8. Números de serie del motor

Modelo	N° de serie	Modelo	N° de serie
E25B	61RK-1014836	25B	61RK-1014836
E30H	61TK-1016671	30H	61TK-1016671

9. Códigos de color aplicables

Abreviatura	Nombre de color	Código de color
DBNM2	DARK BLUISH GRAY METALLIC 2	004D

10. Informacion para la columna de cantidades

Columna N°	Nombre de la columna de cantidades	Modelo aplicable
1	MH	E25BMH, E30HMH, 25BMH, 30HMH
2	WH	30HWH
3	W	25BW, 30HW
4	WC	25BWC, 30HWC

CONTENTS

SHEET1/2

TOP COWLING	A4
CYLINDER & CRANKCASE	A5
CRANKSHAFT & PISTON	A7
INTAKE	B1
CARBURETOR	B3
FUEL	B4
STARTER	B6
GENERATOR	C1
ELECTRICAL 1	C2
ELECTRICAL 2	C4
ELECTRICAL 3	C5
ELECTRICAL 4	C7
STARTING MOTOR	D2
BOTTOM COWLING	D3
STEERING	D5
CONTROL 1	D6
CONTROL 2	E1
REMO CON ATTACHMENT	E2
BRACKET 1	E3
BRACKET 2	E5
UPPER CASING	F1
LOWER CASING & DRIVE 1	F3
LOWER CASING & DRIVE 2	F7

INDEX

NUMERICAL INDEX	G1
-----------------------	----

SHEET2/2

FUEL TANK	A4*
STEERING GUIDE	A5*
REMOTE CONTROL BOX	A6*
REMOTE CONTROL ASSY 1	A7*
REMOTE CONTROL ASSY 2	B3*
SWITCH & PANEL	B5*
OPTIONAL PARTS	B6*
REPAIR KIT 1	C1*
REPAIR KIT 2	C2*

INDEX

NUMERICAL INDEX	G1*
-----------------------	-----

CONTENIDO

PAGINA1/2

SOPORTE SUPERIOR	A4
CYLINDRO & CARTER	A5
CIGUENAL & PISTON	A7
ADMISION	B1
CARBURADOR	B3
COMBUSTIBLE	B4
ARRANQUE	B6
GENERADOR	C1
EQUIPO ELECTRICO 1	C2
EQUIPO ELECTRICO 2	C4
EQUIPO ELECTRICO 3	C5
EQUIPO ELECTRICO 4	C7
MOTOR DE ARRANQUE	D2
CUBIERTA INFERIOR	D3
DIRECCION	D5
CONTROL 1	D6
CONTROL 2	E1
CONJUNTO ADITAMENTO	E2
SOPORTE 1	E3
SOPORTE 2	E5
FUNDA SUPERIOR	F1
IMPULSOR E INFERIOR 1	F3
IMPULSOR E INFERIOR 2	F7

INDICE

INDICE NUMERICO	G1
-----------------------	----

PAGINA2/2

DEPOSITO DE COMBUSTIBLE	A4*
DIRECCIONGUIAR	A5*
CONTROL REMOTO COMPLETO	A6*
CONTROL REMOTO COMPL 1	A7*
CONTROL REMOTO COMPL 2	B3*
PANEL DE INTERRUPTOR	B5*
PARTES OPCIONALES	B6*
ESTUCHE REPARATION 1	C1*
ESTUCHE REPARATION 2	C2*

INDICE

INDICE NUMERICO	G1*
-----------------------	-----

FIG. 1 TOP COWLING

SOPORTE SUPERIOR

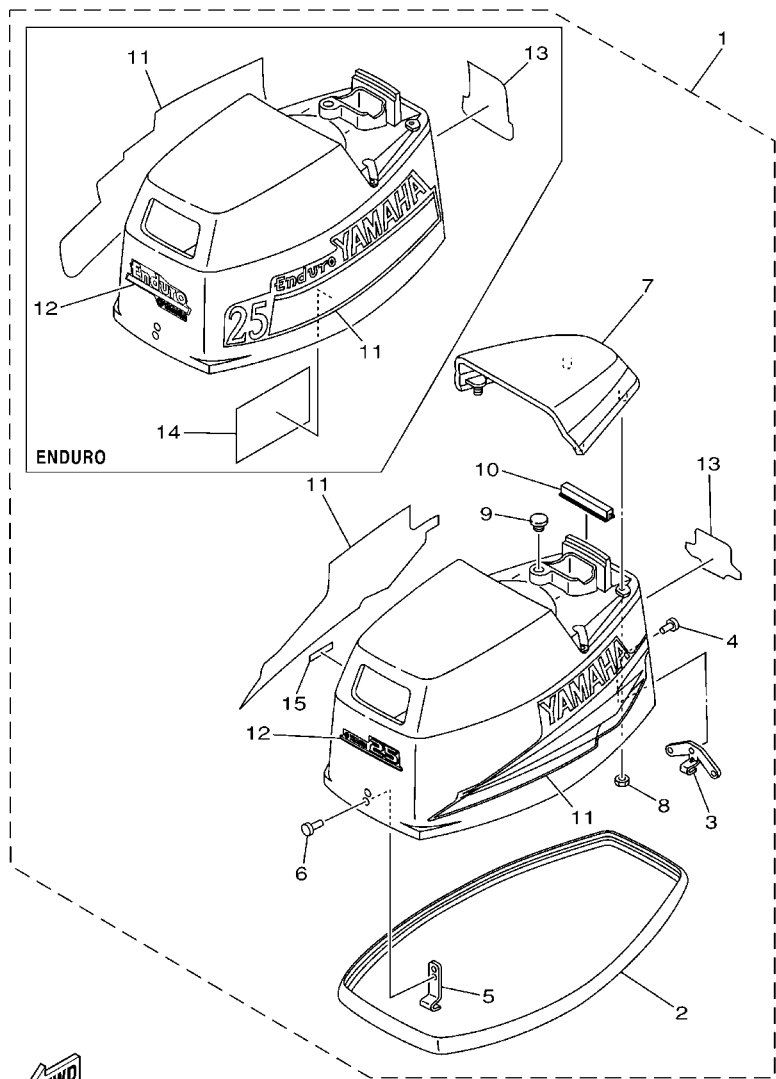

69R2200-2010

REF. NO.	PART NO. CODIGO Nº	DESCRIPTION DESCRIPCION	MH	WH	W	WC	REMARKS OBSERVACIONES
1	69R-42610-20-4D	TOP COWLING ASSY SOPORTE SUPERIOR COMPL.	1		1	1	25B 25B
	69S-42610-20-4D	TOP COWLING ASSY SOPORTE SUPERIOR COMPL.	1	1	1	1	30H 30H
	69P-42610-H0-4D	TOP COWLING ASSY SOPORTE SUPERIOR COMPL.	1				E25B E25B
	60B-42610-H0-4D	TOP COWLING ASSY SOPORTE SUPERIOR COMPL.	1				E30H E30H
2	6G0-42615-00	.SEAL .SELLO	1	1	1	1	
3	689-42647-00	.HOLDER, CLAMP BAND .MORDAZA DE ABRAZADERA	1	1	1	1	
4	90266-04M01	.RIVET .REMACHE	3	3	3	3	
5	6G0-42651-02	.HOOK .GANCHO	1	1	1	1	
6	90266-04M00	.RIVET .REMACHE	2	2	2	2	
7	69P-42613-00-4D	.MOLDING, AIR DUCT .MOLDURA CONDUCTO AIRE	1	1	1	1	
8	90179-06M24	.NUT .TUERCA	4	4	4	4	
9	90480-14M14	.GROMMET .TAPON	1	1	1	1	
10	61N-42628-00	.SEAL .SELLO DE GOMA	1	1	1	1	
11	61R-W0070-10	.GRAPHIC SET .JUEGO DE EMBLEMA	1	1	1	1	25B,30H 25B,30H
	61N-W0070-H0	.GRAPHIC SET .JUEGO DE EMBLEMA	1				E25B E25B
	60B-W0070-H0	.GRAPHIC SET .JUEGO DE EMBLEMA	1				E30H E30H
12	69R-42677-00	.GRAPHIC, FRONT .CALCAMONIA FRONTAL	1		1	1	25B 25B
	69S-42677-00	.GRAPHIC, FRONT .CALCAMONIA FRONTAL	1	1	1	1	30H 30H
	69P-42677-H0	.GRAPHIC, FRONT .CALCAMONIA FRONTAL	1				E25B,E30H E25B,E30H
13	61R-42678-10	.GRAPHIC, REAR .CALCAMONIA TRASERA	1		1	1	25B 25B
	61T-42678-10	.GRAPHIC, REAR .CALCAMONIA TRASERA	1	1	1	1	30H 30H
	61N-42678-H0	.GRAPHIC, REAR .CALCAMONIA TRASERA	1				E25B E25B
	60B-42678-H0	.GRAPHIC, REAR .CALCAMONIA TRASERA	1				E30H E30H
14	677-13437-0B	.MARK, CAUTION .MARKER	1				E25B,E30H E25B,E30H
15	6E0-44191-11	.INDICATOR, SHIFT .INDICADOR DE CAMBIOS	1	1	1	1	25B,30H 25B,30H

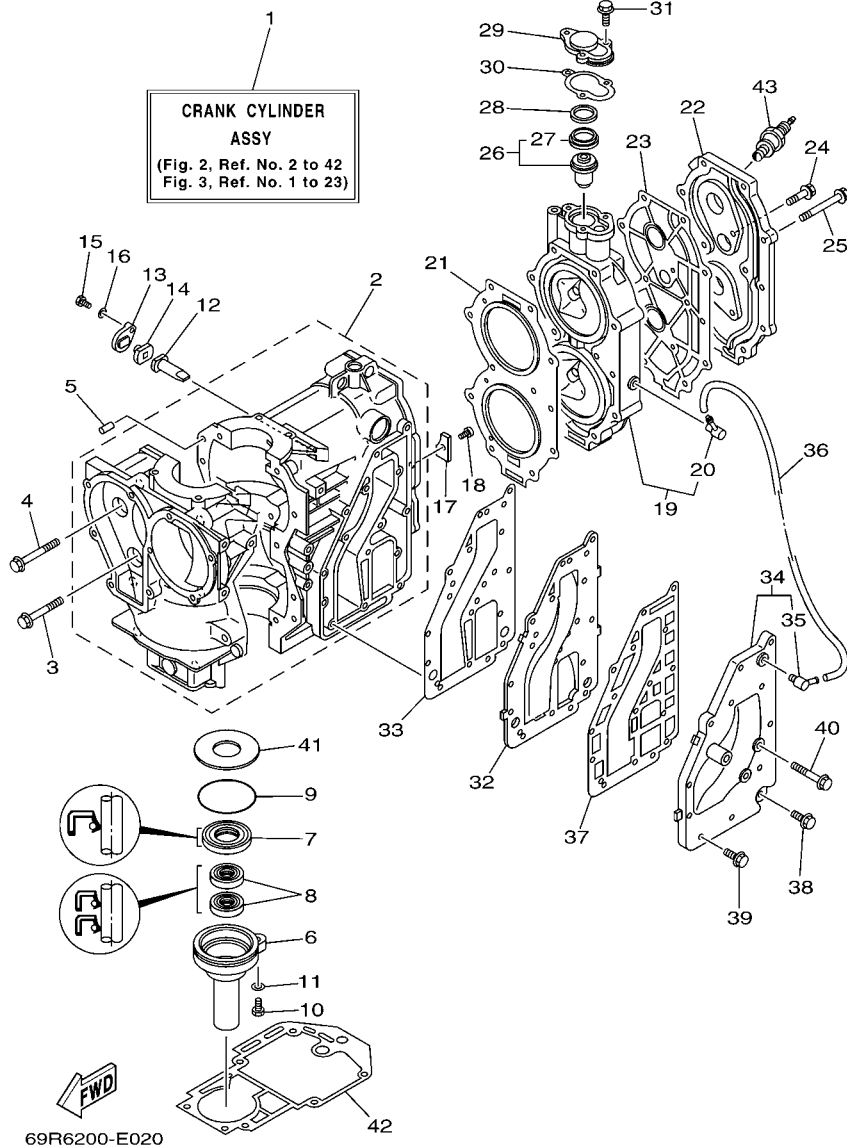

FIG. 2 CYLINDER & CRANKCASE CYLINDRO & CARTER

REF. NO.	PART NO. CODIGO Nº	DESCRIPTION DESCRIPCION	MH	WH	W	WC	REMARKS OBSERVACIONES
1	69P-W0090-00-1S	CRANK CYLINDER ASSY BLOQUE MOTOR COMPLETO	1		1	1	E25B,25B E25B,25B
	69S-W0090-00-1S	CRANK CYLINDER ASSY BLOQUE MOTOR COMPLETO	1	1	1	1	E30H,30H E30H,30H
2	69P-15100-00-1S	CRANKCASE ASSY CARTER COMPLETO	1	1	1	1	
3	90119-08009	BOLT, WITH WASHER TORNILLO CON ARANDELA	2	2	2	2	
4	90119-08M65	BOLT, WITH WASHER TORNILLO CON ARANDELA	8	8	8	8	
5	93606-12019	PIN, DOWEL PASADOR DE CLAVIJA	2	2	2	2	
6	689-15396-01-5B	HOUSING, OIL SEAL CAJA DE SELLO DE ACEITE	1	1	1	1	
7	93102-25008	OIL SEAL SELLO ACEITE	1	1	1	1	
8	93101-16001	OIL SEAL SELLO ACEITE	2	2	2	2	
9	93210-58M21	O-RING ANILLO O	1	1	1	1	
10	97095-06022	BOLT PERNO	1	1	1	1	
11	92995-06600	WASHER ARANDELA	1	1	1	1	
12	6J8-11325-00	ANODE ANODO	1	1	1	1	
13	6H3-11327-00-1S	COVER, ANODE CUBIERTA DE ANODO	1	1	1	1	
14	6H3-11328-00	GROMMET, ANODE TAPON	1	1	1	1	
15	97013-06016	BOLT PERNO	1	1	1	1	
16	92903-06600	WASHER, PLATE RONDANA SENCILLA	1	1	1	1	
17	689-11325-00	ANODE ANODO	1	1	1	1	
18	90151-06M02	SCREW, COUNTERSUNK TORNILLO EMBUTIDO	1	1	1	1	
19	61N-11111-01-1S	HEAD, CYLINDER 1 CULATA CILINDRO 1	1		1	1	E25B,25B E25B,25B
	61T-11111-01-1S	HEAD, CYLINDER 1 CULATA CILINDRO 1	1	1	1	1	E30H,30H E30H,30H
20	676-11372-00	.NIPPLE, HOSE .NIPLE DE MANGUERA	1	1	1	1	
21	61N-11181-A1	GASKET, CYLINDER HEAD 1 JUNTA, DE CULATA 1	1	1	1	1	
22	61N-11191-01-1S	COVER, CYLINDER HEAD 1 TAPA CULATA DE CILINDRO 1	1	1	1	1	
23	61T-11193-A1	GASKET, HEAD COVER 1 EMPAQUE	1	1	1	1	
24	90119-06MA2	BOLT, WITH WASHER TORNILLO CON ARANDELA	2	2	2	2	
25	90119-08015	BOLT, WITH WASHER TORNILLO CON ARANDELA	11	11	11	11	

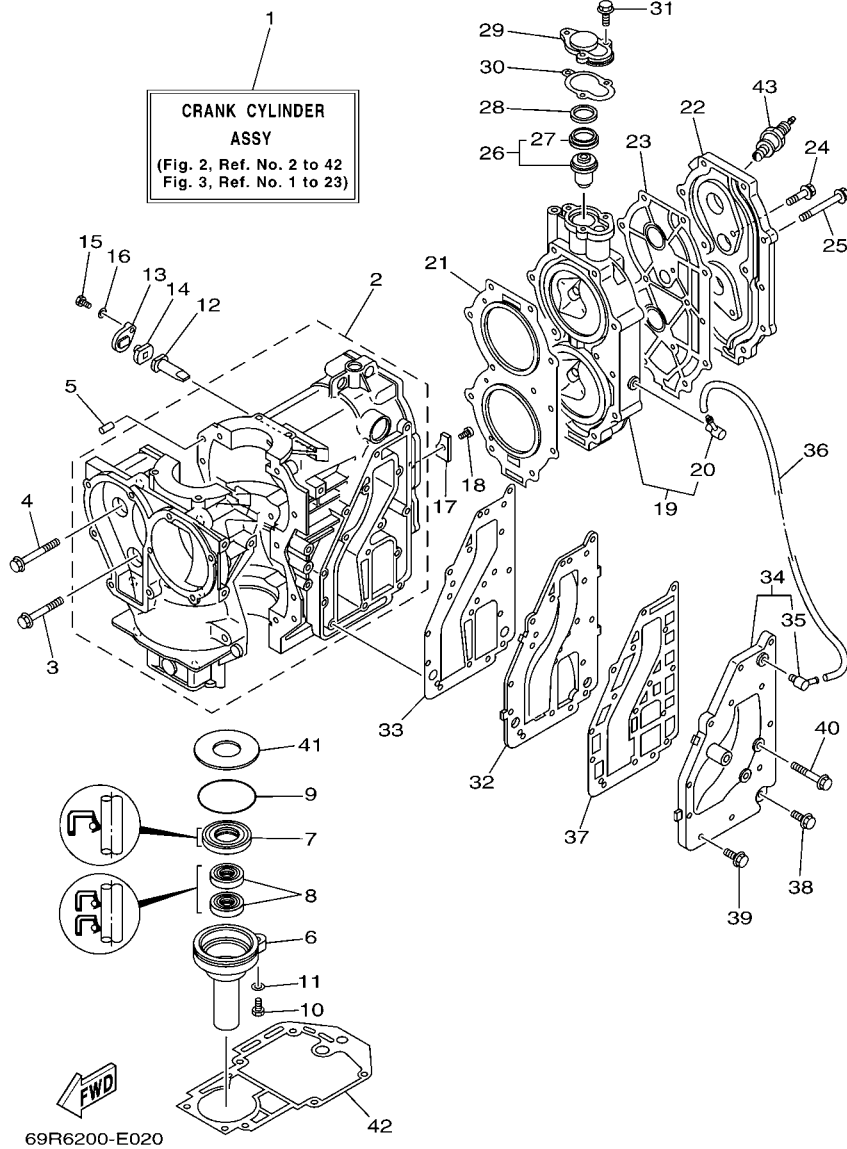
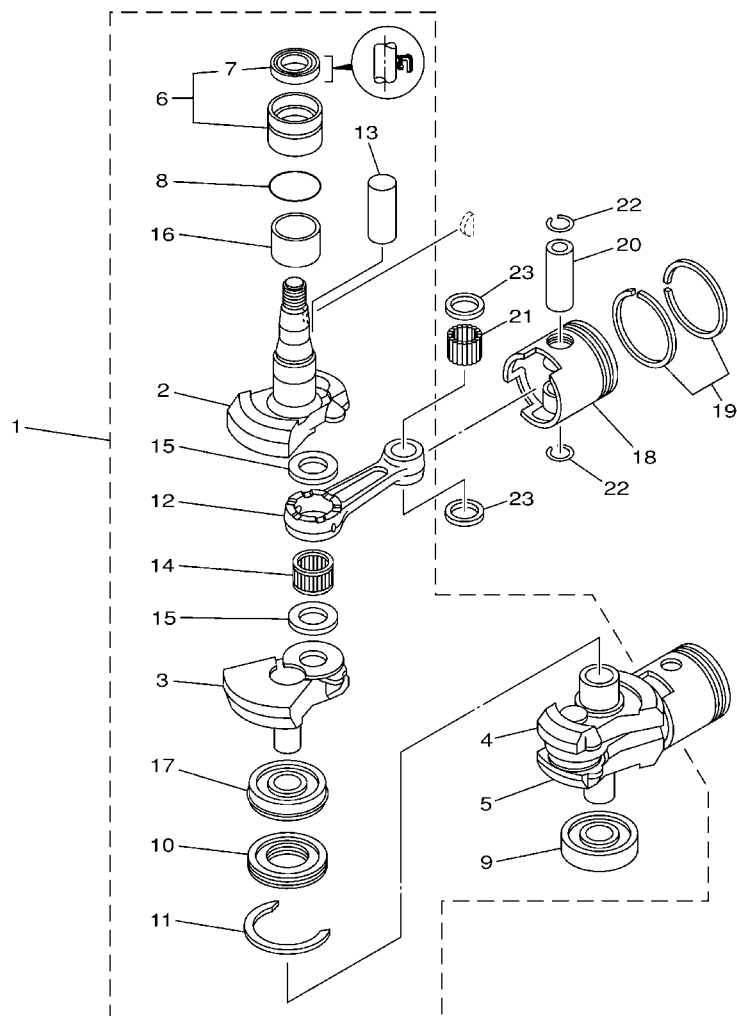

FIG. 2 CYLINDER & CRANKCASE CYLINDRO & CARTER

REF. NO.	PART NO. CODIGO Nº	DESCRIPTION DESCRIPCION	MH	WH	W	WC	REMARKS OBSERVACIONES
26	6E5-12411-02	THERMOSTAT TERMOSTAT	1	1	1	1	
27	6E5-12412-00	.SEAL, THERMOSTAT .SELLO TERMOSTATO	1	1	1	1	
28	90201-21567	WASHER, PLATE ARANDELA PLANA	1	1	1	1	
29	655-12413-01-1S	COVER, THERMOSTAT CUBIERTA TERMOSTATO	1	1	1	1	
30	655-12414-A1	GASKET, COVER EMPAQUE	1	1	1	1	
31	90119-06MA2	BOLT, WITH WASHER TORNILLO CON ARANDELA	3	3	3	3	
32	6K8-41121-00-1S	INNER COVER, EXHAUST CUBIERTA INTERIOR DE ESCAPE	1	1	1	1	
33	6K8-41122-A1	GASKET, EXHAUST INNER COVER EMPAQUE	1	1	1	1	
34	61N-41123-00-1S	OUTER COVER, EXHAUST CUBIERTA EXTERIOR DE ESCAPE	1	1	1	1	
35	676-11372-00	.NIPPLE, HOSE .NIPLE DE MANGUERA	1	1	1	1	
36	90445-10M41	HOSE (L105) TUBO (L105)	1	1	1	1	
37	6K8-41124-A1	GASKET, EXHAUST OUTER COVER EMPAQUE	1	1	1	1	
38	90119-06MA3	BOLT, WITH WASHER TORNILLO CON ARANDELA	1	1	1	1	
39	90119-06MA4	BOLT, WITH WASHER TORNILLO CON ARANDELA	11	11	11	11	
40	90119-06MA0	BOLT, WITH WASHER TORNILLO CON ARANDELA	3	3	3	3	
41	90201-50306	WASHER, PLATE ARANDELA PLANA	1	1	1	1	
42	689-45113-A1	GASKET, UPPER CASING EMPAQUE	1	1	1	1	
43	94702-00217	PLUG, SPARK (NGK B7HS-10) BUJIA (NGK B7HS-10)	2		2	2	E25B,25B E25B,25B
	94702-00160	PLUG, SPARK (NGK B8HS-10) BUJIA (NGK B8HS-10)	2		2	2	E30H,30H E30H,30H
	94702-00271	PLUG, SPARK (NGK BR7HS-10) BUJIA (NGK BR7HS-10)	2				E25B-FOR CAR E25B-FOR CAR
	94702-00247	PLUG, SPARK (NGK BR8HS-10) BUJIA (NGK BR8HS-10)	2		2		30H-FOR CAR,CHN 30H-FOR CAR,CHN

FIG. 3 CRANKSHAFT & PISTON

CIGUENAL & PISTON



FWD
69R0010-1030

REF. NO.	PART NO. CODIGO Nº	DESCRIPTION DESCRIPCION	MH	WH	W	WC	REMARKS OBSERVACIONES
1	69P-11400-00	CRANKSHAFT ASSY CIGUENAL COMPLETO	1	1	1	1	
2	69P-11412-00	.CRANK 1 .MANIVELA 1	1	1	1	1	
3	61N-11422-00	.CRANK 2 .MANIVELA 2	1	1	1	1	
4	61N-11432-00	.CRANK 3 .MANIVELA 3	1	1	1	1	
5	61N-11442-00	.CRANK 4 .MANIVELA 4	1	1	1	1	
6	93399-99951	.BEARING .COJINETE	1	1	1	1	
7	93102-32M07	..OIL SEAL ..SELLO ACEITE	1	1	1	1	
8	93210-46M16	.O-RING .ANILLO O	1	1	1	1	
9	93306-305U3	.BEARING .COJINETE	1	1	1	1	
10	61N-11515-00	.SEAL, LABYRINTH 1 .SELLO LABERINTO 1	1	1	1	1	
11	93440-62057	.CIRCLIP .SEGURO	1	1	1	1	
12	689-11651-00	.ROD, CONNECTING .BIELA	2	2	2	2	
13	689-11681-01	.PIN, CRANK 1 .PASADOR MANIVELA 1	2	2	2	2	
14	93310-62406	.BEARING .COJINETE DE RODILLOS	2	2	2	2	
15	90209-24M03	.WASHER .ARANDELA DE SEPARACION	4	4	4	4	
16	90387-32002	.COLLAR .ESPACIADOR	1	1	1	1	
17	93390-00009	.BEARING .COJINETE DE RODILLOS	1	1	1	1	
18	61N-11631-00-95	PISTON (STD) PISTON (NORMA)	2	2	2	2	
	61N-11635-00	PISTON (0.25MM O/S) PISTON (0.25MM O/S)	2	2	2	2	AP AP
	61N-11636-00	PISTON (0.50MM O/S) PISTON (0.50MM O/S)	2	2	2	2	AP AP
19	61N-11603-00	PISTON RING SET (STD) JUEGO DE ANILLOS (NORMA)	2	2	2	2	
	61N-11604-00	PISTON RING SET (0.25MM O/S) JUEGO DE ANILLOS (0.25MM O/S)	2	2	2	2	AP AP
	61N-11605-00	PISTON RING SET (0.50MM O/S) JUEGO DE ANILLOS (0.50MM O/S)	2	2	2	2	AP AP
20	689-11633-00	PIN, PISTON PASADOR, PISTON	2	2	2	2	
21	93602-20M02	PIN, DOWEL PASADOR DE CLAVIJA	68	68	68	68	
22	688-11634-00	CLIP, PISTON PIN PRESILLA, BULON DE PISTON	4	4	4	4	
23	90201-20M27	WASHER, PLATE ARANDELA PLANA	4	4	4	4	

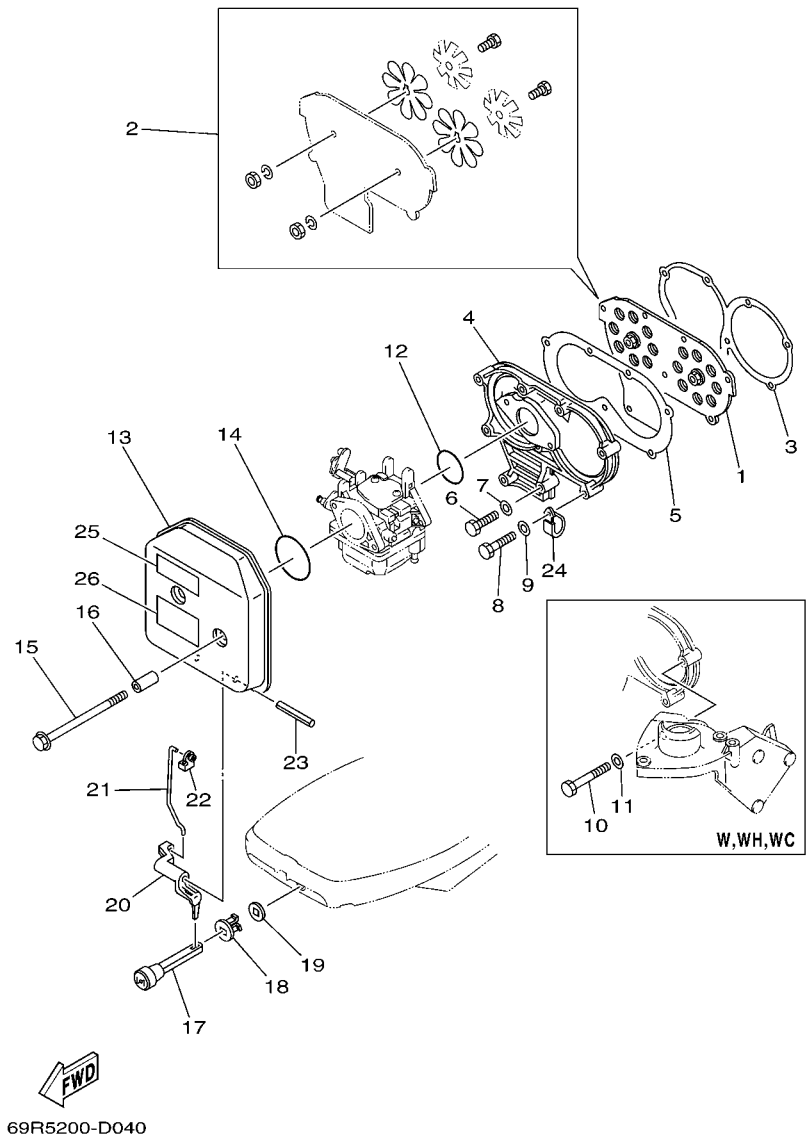

FIG. 4 INTAKE

ADMISION

REF. NO.	PART NO. CODIGO N°	DESCRIPTION DESCRIPCION	MH	WH	W	WC	REMARKS OBSERVACIONES
1	61N-13610-00	REED VALVE ASSY VALVULA DE LAMINAS COMPLETA	1		1	1	E25B,25B E25B,25B
	689-13610-01	REED VALVE ASSY VALVULA DE LAMINAS COMPLETA	1	1	1	1	E30H,30H E30H,30H
2	689-W0004-00	.REED SET .JUEGO DE VALVULAS DE LENGUETA	1	1	1	1	
3	648-13621-A1	GASKET, VALVE SEAT JUNTA, DE VALV.DE EMPAQUE	1	1	1	1	
4	61N-13641-01-1S	MANIFOLD 1 MULTIPLE 1	1	1	1	1	
5	648-13645-A0	GASKET, MANIFOLD 1 EMPAQUE	1	1	1	1	
6	97013-06025	BOLT PERNO	2	2	2	2	
7	92903-06600	WASHER, PLATE RONDANA SENCILLA	2	2	2	2	
8	97013-06035	BOLT PERNO	7				
	97013-06035	BOLT PERNO		6	6	6	
9	92903-06600	WASHER, PLATE RONDANA SENCILLA	7				
	92903-06600	WASHER, PLATE RONDANA SENCILLA		6	6	6	
10	97013-06050	BOLT PERNO		1	1	1	
11	92903-06600	WASHER, PLATE RONDANA SENCILLA		1	1	1	
12	61N-14198-00	GASKET EMPAQUE	1	1	1	1	
13	61N-14440-00	SILENCER ASSY, INTAKE SILENCIADOR COMPL DE ADMISION	1	1	1	1	
14	93210-40659	O-RING ANILLO O	1	1	1	1	
15	90119-06M94	BOLT, WITH WASHER TORNILLO CON ARANDELA	2	2	2	2	
16	90387-06M26	COLLAR ESPACIADOR	2	2	2	2	
17	682-41271-00	KNOB, CHOKE PERILLA AHOGADOR	1	1	1	1	
18	689-41273-00	GROMMET TAPON PROTECTOR	1	1	1	1	
19	6J8-41274-00	GROMMET 2 TAPON 2	1	1	1	1	
20	689-41252-01	LEVER, CHOKE 1 PALANCA AHOGADOR 1	1	1	1	1	
21	61N-41256-00	ROD, CHOKE 1 VARILLA DE AHOGADOR	1	1	1	1	
22	661-41262-02	JOINT, CHOKE LEVER CONECTOR DE AHOGADOR	1	1	1	1	
23	91690-40048	PIN, SPRING PASADOR DE RESORTE	1	1	1	1	
24	90465-06M88	CLAMP BRIDA	1	1	1	1	

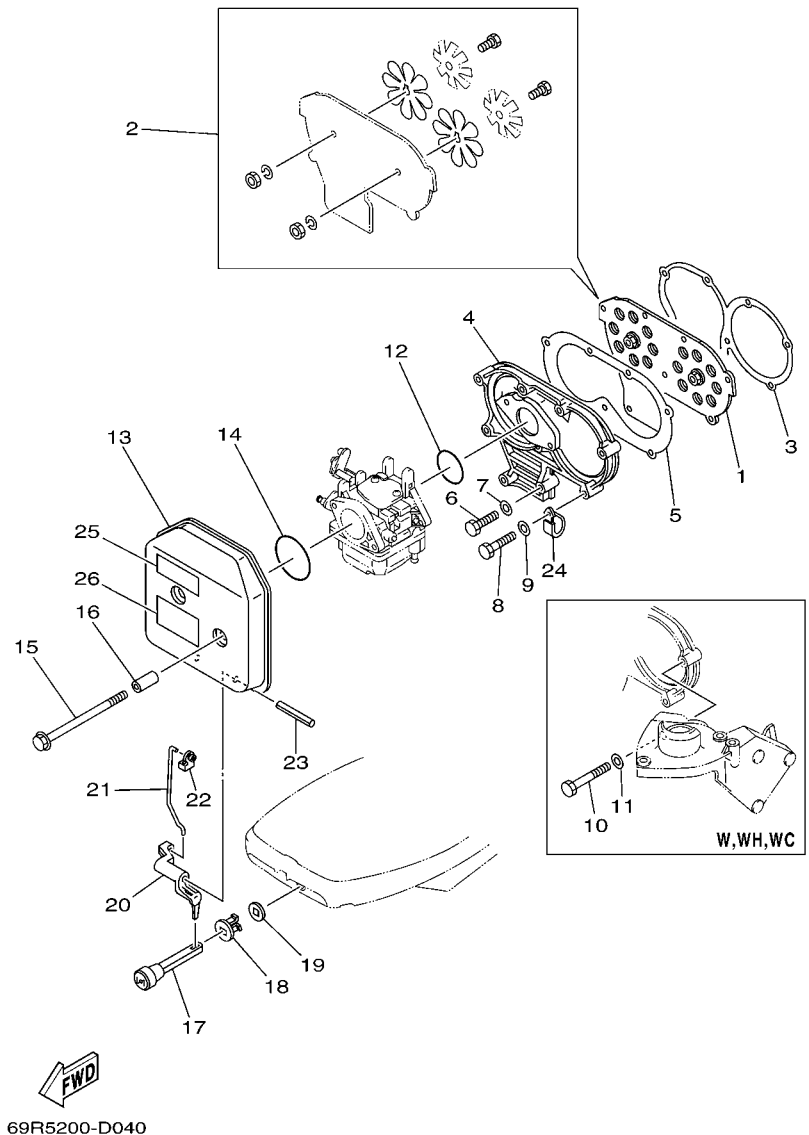

FIG. 4 INTAKE

ADMISION

REF. NO.	PART NO. CODIGO Nº	DESCRIPTION DESCRIPCION	MH	WH	W	WC	REMARKS OBSERVACIONES
25	6A1-83625-41	MARK 5 MARCA 5	1	1	1	1	
26	61T-83625-80	MARK 5 MARCA 5	1	1	1	1	FOR RUS FOR RUS

FIG. 5 CARBURETOR

CARBURADOR

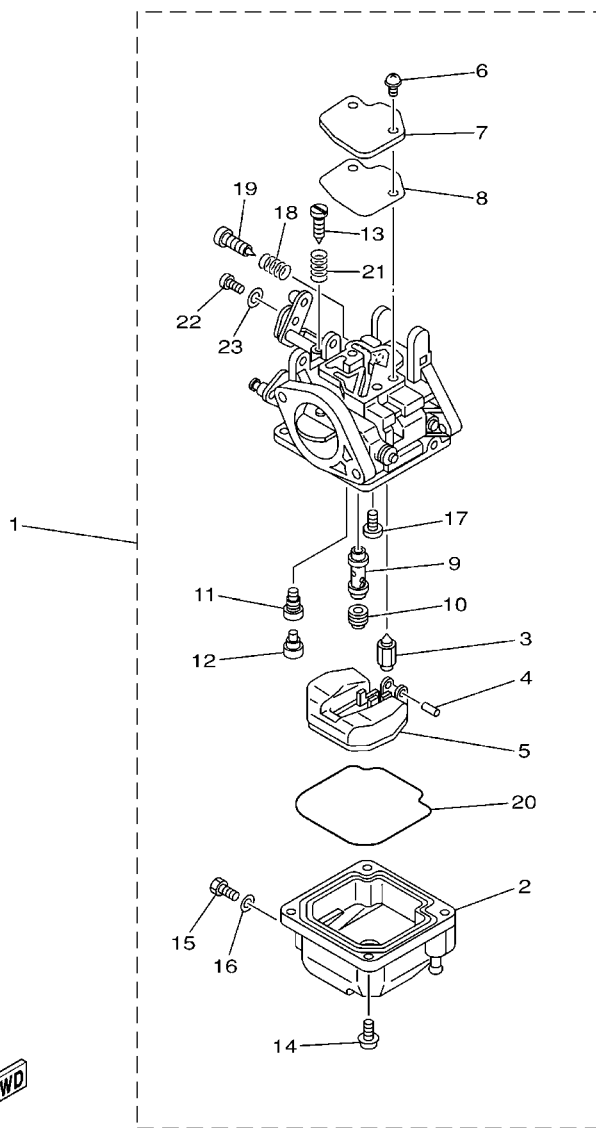

69R0010-1050

REF. NO.	PART NO. CODIGO Nº	DESCRIPTION DESCRIPCION	MH	WH	W	WC	REMARKS OBSERVACIONES
1	69P-14301-00	CARBURETOR ASSY 1 CARBURADOR COMPLETO 1	1		1	1	E25B,25B E25B,25B
	69S-14301-00	CARBURETOR ASSY 1 CARBURADOR COMPLETO 1	1	1	1	1	E30H,30H E30H,30H
2	61N-14381-00	.BODY, FLOAT CHAMBER .CUERPO DE CAMARA DE BOIA	1	1	1	1	
3	61N-14392-00	.VALVE, NEEDLE .VALVULA DE AGUJA	1	1	1	1	
4	6E5-14386-01	.PIN, FLOAT .PASADOR DE BOIA	1	1	1	1	
5	6L2-14385-00	.FLOAT .BOIA	1	1	1	1	
6	97980-04110	.SCREW, WITH WASHER .TORNILLO, CON ARANDELA	2	2	2	2	
7	6L2-14157-00	.COVER, MIXING .CUBIERTA DE MEZCLA	1	1	1	1	
8	6L2-14399-00	.GASKET .EMPAQUE	1	1	1	1	
9	61N-14341-00	.NOZZLE, MAIN .BOQUILLA PRINCIPAL	1		1	1	FOR 69P-14301-00 FOR 69P-14301-00
	61T-14341-00	.NOZZLE, MAIN .BOQUILLA PRINCIPAL	1	1	1	1	FOR 69S-14301-00 FOR 69S-14301-00
10	61N-14343-65	.JET, MAIN (#130) .INYECTOR PRINCIPAL (#130)	1	1	1	1	
11	6L2-14342-34	.JET, PILOT (# 68) .ESPREA DE PILOTO (# 68)	1	1	1	1	
12	50M-14355-00	.PLUG .TAPON	1	1	1	1	
13	664-14321-01	.SCREW, THROTTLE .TORNILLO DE OBTURADOR	1	1	1	1	
14	97980-04112	.SCREW, WITH WASHER .TORNILLO, CON ARANDELA	4	4	4	4	
15	677-14383-01	.SCREW, DRAIN .TORNILLO DE DRENAJE	1	1	1	1	
16	6L2-14398-00	.GASKET .EMPAQUE	1	1	1	1	
17	98980-04006	.SCREW, BIND .TORNILLO DE LIGAR	2	2	2	2	
18	646-14212-01	.SPRING, PILOT ADJUSTING .RESORTE DE AJUSTE DE PILOTO	1	1	1	1	
19	61N-14323-00	.SCREW, AIR ADJUSTING .TORNILLO DE AJUSTE DE AIRE	1	1	1	1	
20	6L2-14384-00	.GASKET, FLOAT CHAMBER .EMPAQUE DE CAMARA DE BOIA	1	1	1	1	
21	61N-14212-00	.SPRING, PILOT ADJUSTING .RESORTE DE AJUSTE DE PILOTO	1	1	1	1	
22	97890-05006	.SCREW, PAN HEAD .TORNILLO	1	1	1	1	
23	62Y-14597-00	.WASHER .ARANDELA	1	1	1	1	

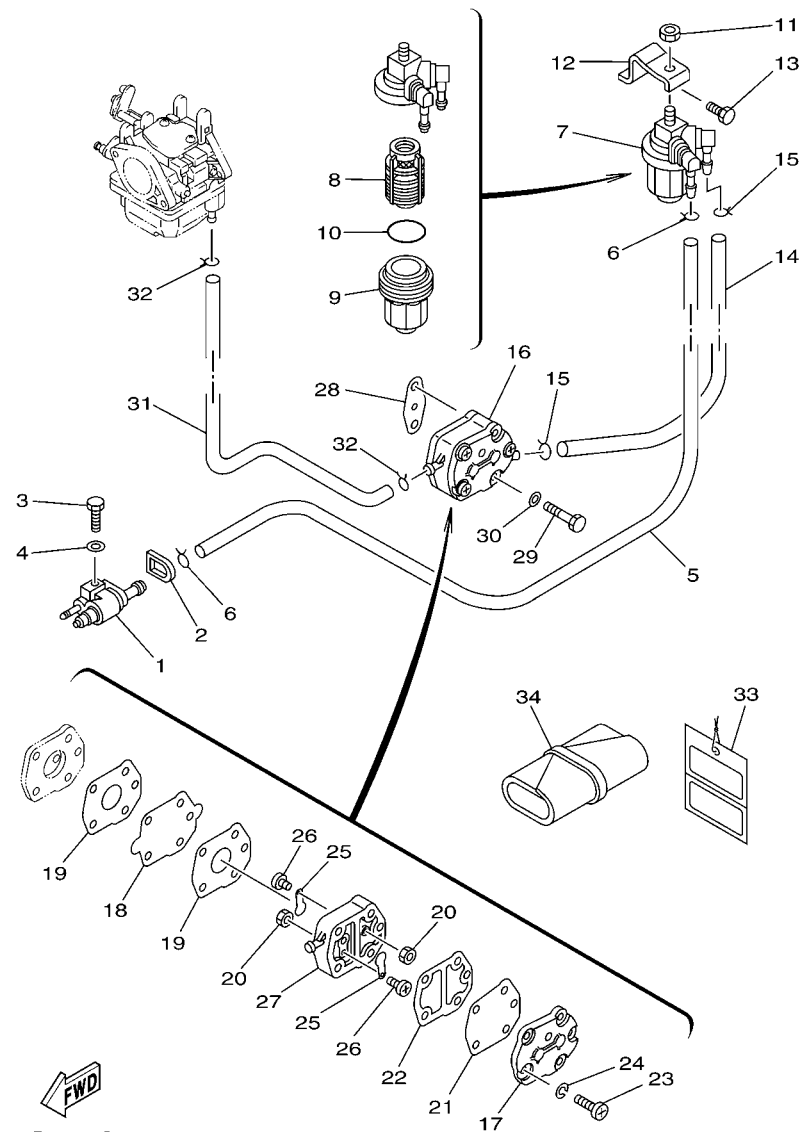

69R4700-C060

FIG. 6 FUEL

COMBUSTIBLE

REF. NO.	PART NO. CODIGO Nº	DESCRIPTION DESCRIPCION	MH	WH	W	WC	REMARKS OBSERVACIONES
1	6G1-24304-02	FUEL PIPE JOINT COMP. 1 CONECTOR MANGUERA COMBUST.1	1	1	1	1	
2	61N-24329-00	SEAL SELLO	1	1	1	1	
3	97095-06020	BOLT PERNO	1	1	1	1	
4	92995-06600	WASHER ARANDELA	1	1	1	1	
5	90445-09M75	HOSE (L370) TUBO (L370)	1	1	1	1	
6	90467-08004	CLIP PRESILLA	2	2	2	2	
7	61N-24560-00	FILTER ASSY FILTRO COMPLETO	1	1	1	1	
8	61N-24563-00	.ELEMENT, FILTER .ELEMENTO DEL FILTRO	1	1	1	1	
9	61N-24521-00	.CUP, FILTER .COPA DE FILTRO	1	1	1	1	
10	93210-32738	.O-RING .ANILLO O	1	1	1	1	
11	95380-08600	NUT TUERCA	1	1	1	1	
12	61N-24566-01	BRACKET, FILTER SOPORTE DEL FILTRO	1	1	1	1	
13	97013-06014	BOLT PERNO	1	1	1	1	
14	689-24311-00	PIPE, FUEL 1 TUBO DE COMBUSTIBLE 1	1	1	1	1	
15	90467-08004	CLIP PRESILLA	2	2	2	2	
16	692-24410-00	FUEL PUMP ASSY BOMBA DE COMBUSTIBLE COMPLETA	1	1	1	1	
17	6A0-24413-00	.BODY 2 .CUERPO 2	1	1	1	1	
18	692-24411-00	.DIAPHRAGM .DIAFRAGMA	1	1	1	1	
19	648-24434-01	.GASKET, BODY .EMPAQUE	2	2	2	2	
20	95380-03600	.NUT .TUERCA	2	2	2	2	
21	663-24411-00	.DIAPHRAGM .DIAFRAGMA	1	1	1	1	
22	648-24435-02	.GASKET, BODY 2 .EMPAQUE	1	1	1	1	
23	98503-05028	.SCREW, PAN HEAD .TORNILLO DE CABEZA DE CONO AC	3	3	3	3	
24	92990-05100	.WASHER, SPRING .ARANDELA PLANA	3	3	3	3	
25	6A0-24421-01	.VALVE, CHECK .VALVULA DE RETENCION	2	2	2	2	
26	6A0-14325-00	.SCREW, PAN HEAD .TORNILLO CABEZA REDONDA	2	2	2	2	
27	6A0-24412-02	.BODY 1 .CUERPO 1	1	1	1	1	

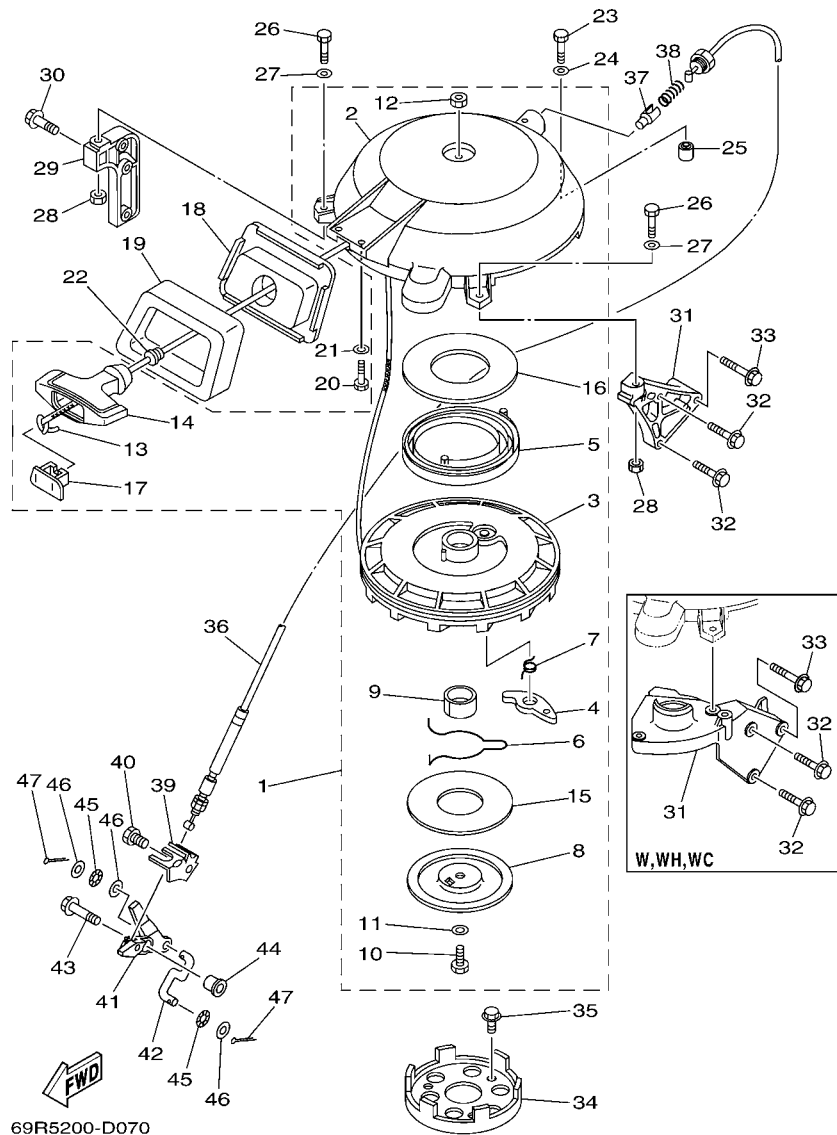

69R5200-D070

*1: CUT FROM 50M ROLLS, PART NO.90890-44373, CUTTING LENGTH 1.9M

*1:CORTE DE UN RODILLO DE 50M , PARTS NUMERO 90890-44373, LARGO DEL CORTE 1.9M

FIG. 7 STARTER

ARRANQUE

REF. NO.	PART NO. CODIGO Nº	DESCRIPTION DESCRIPCION	MH	WH	W	WC	REMARKS OBSERVACIONES
1	61N-W1571-11	STARTER ASSY ARRANQUE COMPLETO	1	1	1	1	
2	61N-15711-10	.CASE, STARTER .CAJA DE ARRANQUE	1	1	1	1	
3	6G0-15714-01	.DRUM, SHEAVE .TAMBOR ROLDANA	1	1	1	1	
4	6F5-15741-01	.PAWL, DRIVE .TRINQUETE DE TRACCION	1	1	1	1	
5	6F5-15713-01	.SPRING, STARTER .RESORTE DE ARRANQUE	1	1	1	1	
6	61N-15715-00	.SPRING, FRICTION .RESORTE PLACA DE TRACCION	1	1	1	1	
7	61N-15734-00	.SPRING, RETURN .RESORTE DE RETORNO	1	1	1	1	
8	6F5-15716-01	.PLATE, DRIVE .PLACA DE TRACCION	1	1	1	1	
9	6G0-15754-00	.BUSH 2 .BUJE 2	1	1	1	1	
10	97013-08030	.BOLT .PERNO	1	1	1	1	
11	6F5-15726-01	.WASHER, FLAT .ARANDELA PLANA	1	1	1	1	
12	95303-08700	.NUT .TUERCA	1	1	1	1	
13	*	.WIRE (L:1900MM) .CABLE (L:1900MM)	1	1	1	1	*1 *1
14	689-15755-01	.HANDLE, STARTER .MANIJA DE ARRANQUE	1	1	1	1	
15	6F5-15764-00	.COLLAR 1 .COLLAR 1	1	1	1	1	
16	6F5-15739-00	.WASHER, THRUST .ARANDELA DE EMPUJE AXIAL	1	1	1	1	
17	6F5-15779-02	.COVER .CUBIERTA	1	1	1	1	
18	61N-15758-01-4D	GUIDE, ROPE GUIA DE CUERDA	1	1	1	1	
19	61N-15762-00	SEAL, RUBBER 2 SELLO DE GOMA 2	1	1	1	1	
20	97095-06016	BOLT PERNO	2	2	2	2	
21	92995-06600	WASHER ARANDELA	2	2	2	2	
22	6A0-15789-00	DAMPER AMORTIGUADOR	1	1	1	1	
23	97095-06035	BOLT PERNO	1	1	1	1	
24	92995-06600	WASHER ARANDELA	1	1	1	1	
25	99530-10014	PIN, DOWEL PASADOR, DE ESPIGA	1	1	1	1	
26	97095-06035	BOLT PERNO	2	2	2	2	
27	92995-06600	WASHER ARANDELA	2	2	2	2	

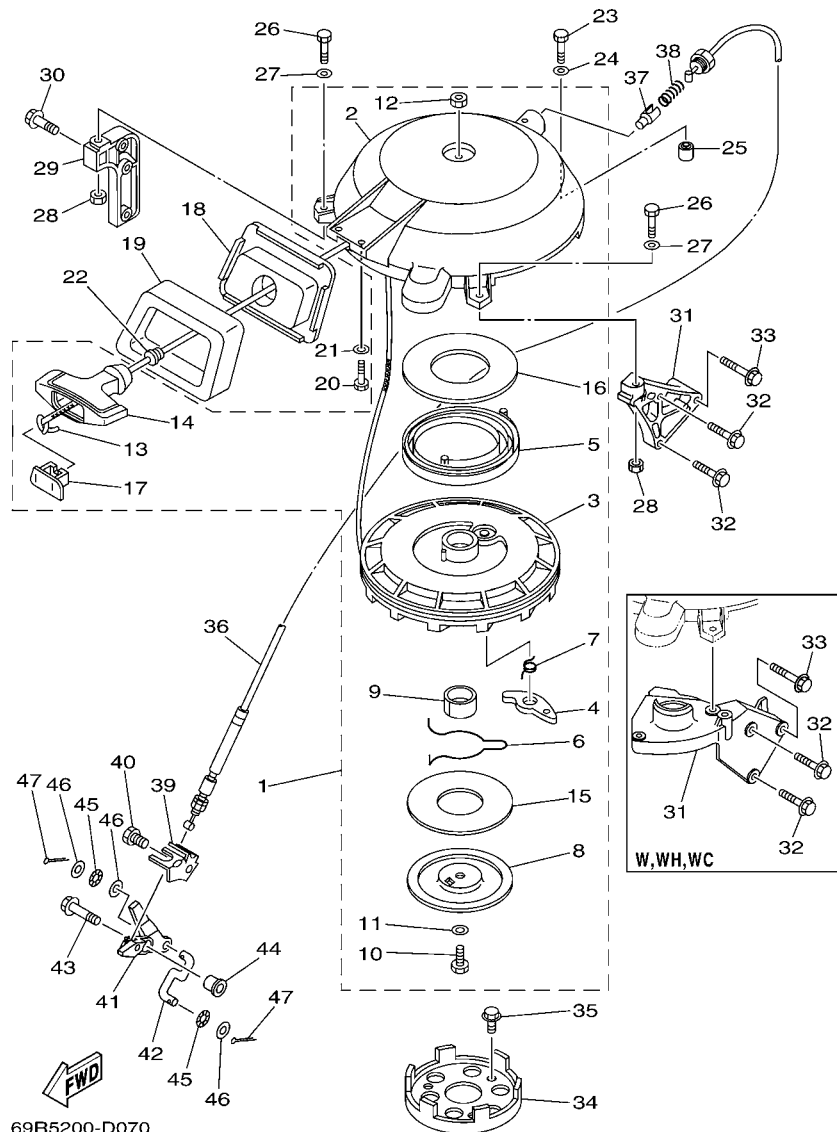

69R5200-D070

*1: CUT FROM 50M ROLLS, PART NO. 90890-44373, CUTTING LENGTH 1.9M

*1: CORTE DE UN RODILLO DE 50M , PARTS NUMERO 90890-44373, LARGO DEL CORTE 1.9M

FIG. 7 STARTER

ARRANQUE

REF. NO.	PART NO. CODIGO Nº	DESCRIPTION DESCRIPCION	MH	WH	W	WC	REMARKS OBSERVACIONES
28	95380-06600	NUT, HEXAGON TUERCA	2				
	95380-06600	NUT, HEXAGON TUERCA		1	1	1	
29	6H7-15771-01-94	STAY 1 SOPORTE 1	1	1	1	1	
30	90119-06MA3	BOLT, WITH WASHER TORNILLO CON ARANDELA	2	2	2	2	
31	656-15772-00-94	STAY 2 SOPORTE 2	1				
	61T-15772-01-94	STAY 2 SOPORTE 2		1	1	1	
32	90119-06MA3	BOLT, WITH WASHER TORNILLO CON ARANDELA	2				
	90119-06MA4	BOLT, WITH WASHER TORNILLO CON ARANDELA		2	2	2	
33	90119-06025	BOLT, WITH WASHER TORNILLO CON ARANDELA	1	1	1	1	
34	6F5-15723-01	PULLEY, STARTER POLEA DE ARRANQUE	1	1	1	1	
35	90105-08M10	BOLT, FLANGE TORNILLO	3	3	3	3	
36	61T-15770-00	CABLE COMP., STARTER STOP CABLECOMPL DE SEGURO ARRANQUE	1	1	1	1	
37	656-15748-00	PLUNGER, STARTER STOP EMBOLO SEGURO DE ARRANQUE	1	1	1	1	
38	90501-10227	SPRING, COMPRESSION RESORTE DE COMPRESION	1	1	1	1	
39	69P-15774-00	STAY 4 SOPORTE 4	1	1	1	1	
40	97095-06010	BOLT PERNO	1	1	1	1	
41	69P-15746-00	ARM BRAZO	1	1	1	1	
42	689-15747-70	LINK ESLABON	1	1	1	1	
43	90119-06M23	BOLT, WITH WASHER TORNILLO CON ARANDELA	1	1	1	1	
44	90387-06013	COLLAR ESPACIADOR	1	1	1	1	
45	90206-05005	WASHER, WAVE ARANDELA ONDULADA	2	2	2	2	
46	92903-05600	WASHER, PLATE RONDANA SENCILLA	3	3	3	3	
47	91490-16010	PIN, COTTER CHAVETA	2	2	2	2	

FIG. 8 GENERATOR

GENERADOR

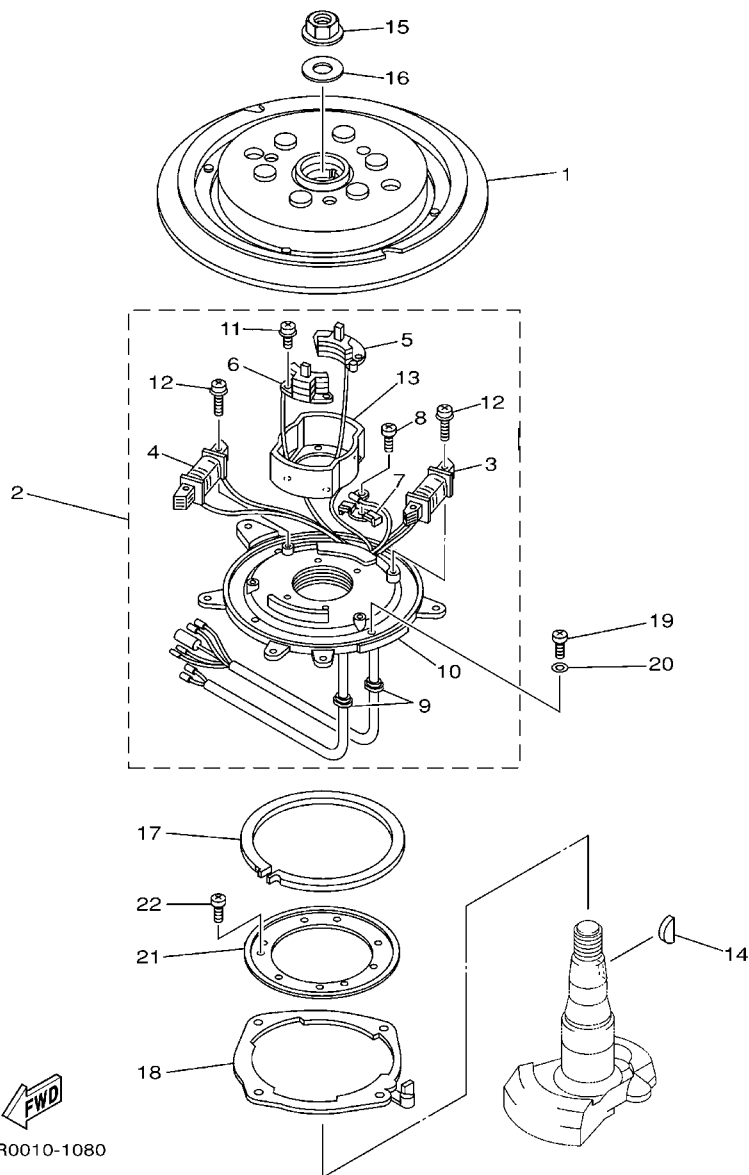

69R0010-1080

REF. NO.	PART NO. CODIGO Nº	DESCRIPTION DESCRIPCION	MH	WH	W	WC	REMARKS OBSERVACIONES
1	61N-85550-10	ROTOR ASSY ROTOR COMPLETO	1				
	61T-85550-10	ROTOR ASSY ROTOR COMPLETO		1	1	1	
2	69P-85560-00	BASE ASSY CONJUNTO BASE	1	1	1	1	
3	69P-85541-09	.COIL, CHARGE .BOBINA DE CARGA	1	1	1	1	
4	61N-81313-09	.COIL, LIGHTING 1 .BOBINA DE ILUMINACION 1	1	1	1	1	
5	61N-85543-09	.COIL, PULSER .BOBINA DE PULSACION	1	1	1	1	
6	61N-85543-19	.COIL, PULSER .BOBINA DE PULSACION	1	1	1	1	
7	6E9-81328-70	.CLAMP .GRAMPA	1	1	1	1	
8	97802-04006	.SCREW, PAN HEAD .TORNILLO	1	1	1	1	
9	6E9-85516-70	.GROMMET .ESPACIADOR	2	2	2	2	
10	69P-85561-00	.BASE, MAGNETO .BASE DE MAGNETO	1	1	1	1	
11	97607-04112	.SCREW, WITH WASHER .TORNILLO CAB CON PLANA C/ARAN	4	4	4	4	
12	97607-06125	.SCREW, WITH WASHER .TORNILLO CAB CON PLANA C/ARAN	4	4	4	4	
13	61N-85537-00	.COVER .CUBIERTA	1	1	1	1	
14	90280-05015	KEY, WOODRUFF CUNA WOODRUFF	1	1	1	1	
15	90179-16M05	NUT TUERCA	1	1	1	1	
16	90201-16M44	WASHER, PLATE ARANDELA PLANA	1	1	1	1	
17	676-41611-00	RETAINER, MAGNETO BASE RETENEDOR BASE MAGNETO	1	1	1	1	
18	676-41613-00	PLATE, BASE FRICTION PLACA DE BASE DE FRICCION	1	1	1	1	
19	97880-05012	SCREW, PAN HEAD TORNILLO DE CABEZA CON PLANA	4	4	4	4	
20	92990-05600	WASHER, PLATE ARANDELA PLANA	4	4	4	4	
21	689-41612-01	RETAINER, MAGNETO BASE RETENEDOR BASE MAGNETO	1	1	1	1	
22	97880-06010	SCREW, PAN HEAD TORNILLO DE CABEZA CON PLANA	4	4	4	4	

FIG. 9 ELECTRICAL 1

EQUIPO ELECTRICO 1

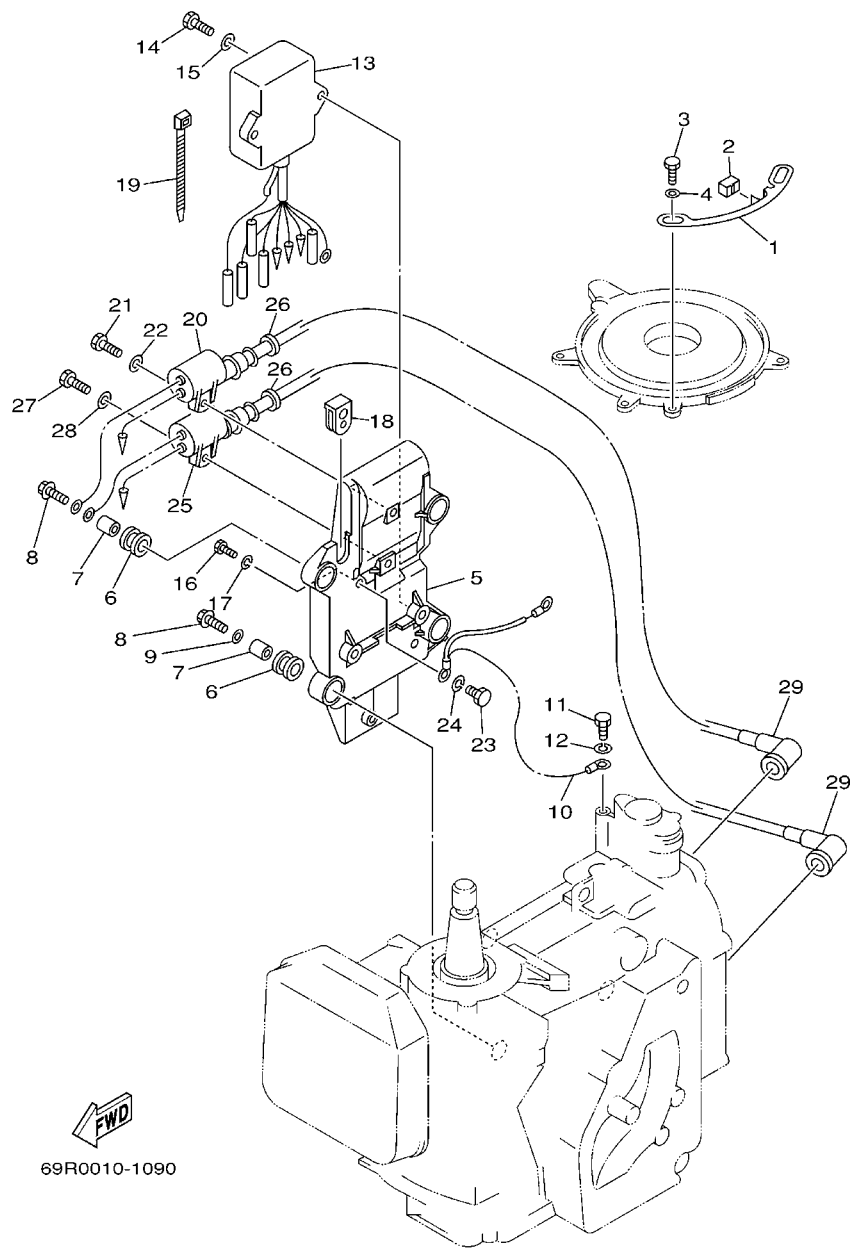

69R0010-1090

REF. NO.	PART NO. CODIGO Nº	DESCRIPTION DESCRIPCION	MH	WH	W	WC	REMARKS OBSERVACIONES
1	61N-41615-00	STOPPER, MAGNETO BASE RETENEDOR, BASE MAGNETO	1	1	1	1	
2	61N-44194-01	CAP TAPA	1	1	1	1	E25B,25B E25B,25B
	61T-44194-01	CAP TAPA	1	1	1	1	E30H,30H E30H,30H
3	97095-06010	BOLT PERNO	2	2	2	2	
4	92995-06600	WASHER ARANDELA	2	2	2	2	
5	61N-85542-00-94	BRACKET SOPORTE	1	1	1	1	
6	61N-82317-00	DAMPER, IGNITION COIL AMORTIGUADOR BOBINA ENCENDIDO	4	4	4	4	
7	90387-06119	COLLAR ESPACIADOR	4	4	4	4	
8	90119-06M95	BOLT, WITH WASHER TORNILLO CON ARANDELA	4	4	4	4	
9	90201-06M30	WASHER, PLATE ARANDELA PLANA	2	2	2	2	
10	61N-82519-01	WIRE, EARTH LEAD CABLE CONDUCTOR A TIERRA	1	1	1	1	
11	97090-06012	BOLT PERNO	1	1	1	1	
12	92990-06100	WASHER, SPRING ARANDELA PLANA	1	1	1	1	
13	61N-85540-13	C.D.I. UNIT ASSY UNIDAD C.D.I. COMPLETA	1	1	1	1	
14	97095-06020	BOLT PERNO	2	2	2	2	
15	92995-06600	WASHER ARANDELA	2	2	2	2	
16	97090-06012	BOLT PERNO	1	1	1	1	
17	92990-06100	WASHER, SPRING ARANDELA PLANA	1	1	1	1	
18	6H3-81922-00	GROMMET TAPON PROTECTOR	1	1	1	1	
19	90465-13M11	CLAMP BRIDA	1	1	1	1	
20	61N-85570-00	IGNITION COIL ASSY BOBINA DE IGNICION COMPLETO	1	1	1	1	
	6H5-85570-00	IGNITION COIL ASSY BOBINA DE IGNICION COMPLETO	1				30H-FOR CAR 30H-FOR CAR
21	97095-06020	BOLT PERNO	1	1	1	1	
22	92995-06600	WASHER ARANDELA	1	1	1	1	
23	97090-06012	BOLT PERNO	1	1	1	1	
24	92990-06100	WASHER, SPRING ARANDELA PLANA	1	1	1	1	
25	61N-85570-10	IGNITION COIL ASSY BOBINA DE IGNICION COMPLETO	1	1	1	1	

FIG. 9 ELECTRICAL 1

EQUIPO ELECTRICO 1

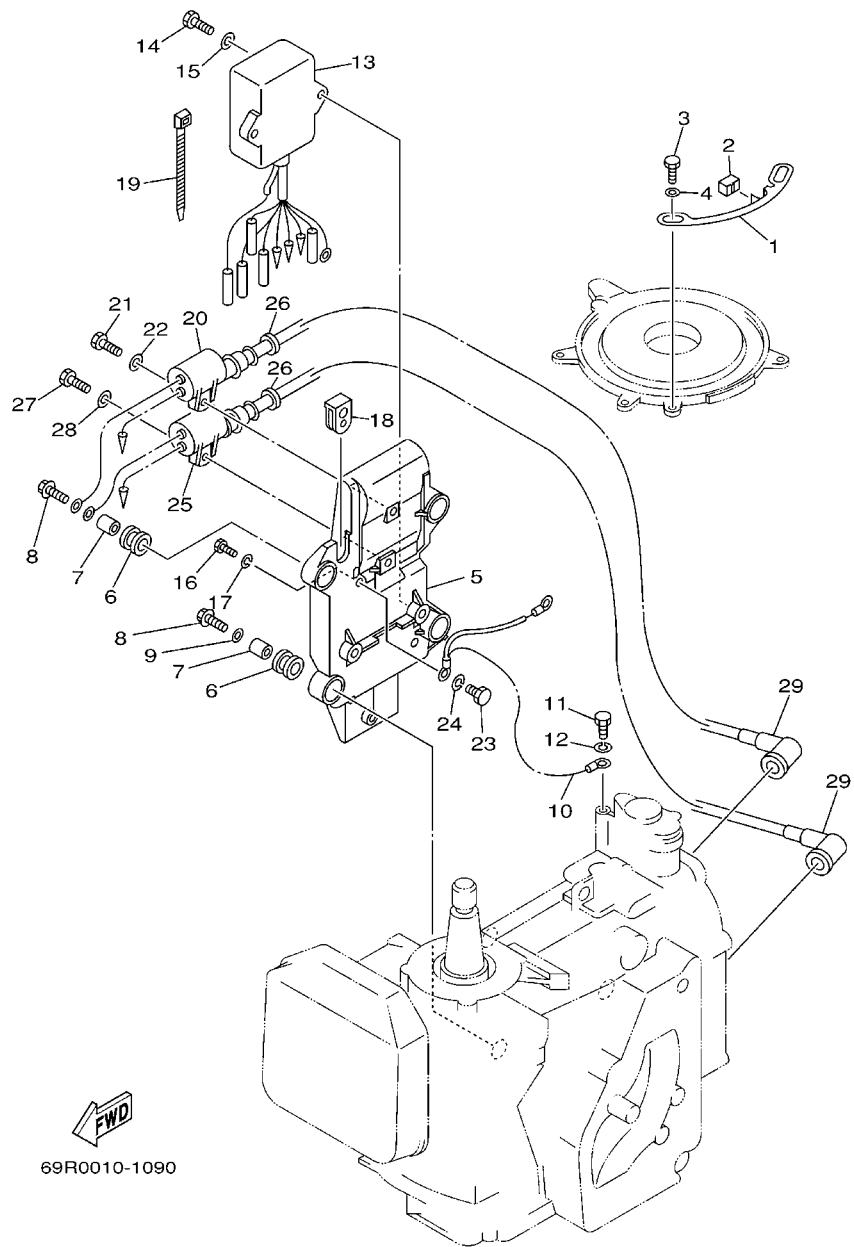

69R0010-1090

REF. NO.	PART NO. CODIGO Nº	DESCRIPTION DESCRIPCION	MH	WH	W	WC	REMARKS OBSERVACIONES
25	61N-85570-00	IGNITION COIL ASSY BOBINA DE IGNICION COMPLETO	1				30H-FOR CAR 30H-FOR CAR
26	90480-25161	GROMMET TAPON	2	2	2	2	
27	97095-06020	BOLT PERNO	1	1	1	1	
28	92995-06600	WASHER ARANDELA	1	1	1	1	
29	663-82370-01	PLUG CAP ASSY TAPON DE BUJIA COMPLT	2	2	2	2	25B,30H 25B,30H
	66T-82370-00	PLUG CAP ASSY TAPON DE BUJIA COMPLT	2				E25B,E30H E25B,E30H
	6G1-82370-21	PLUG CAP ASSY TAPON DE BUJIA COMPLT	2				E25B,30H-FOR CAR E25B,30H-FOR CAR

FIG. 10 ELECTRICAL 2

EQUIPO ELECTRICO 2

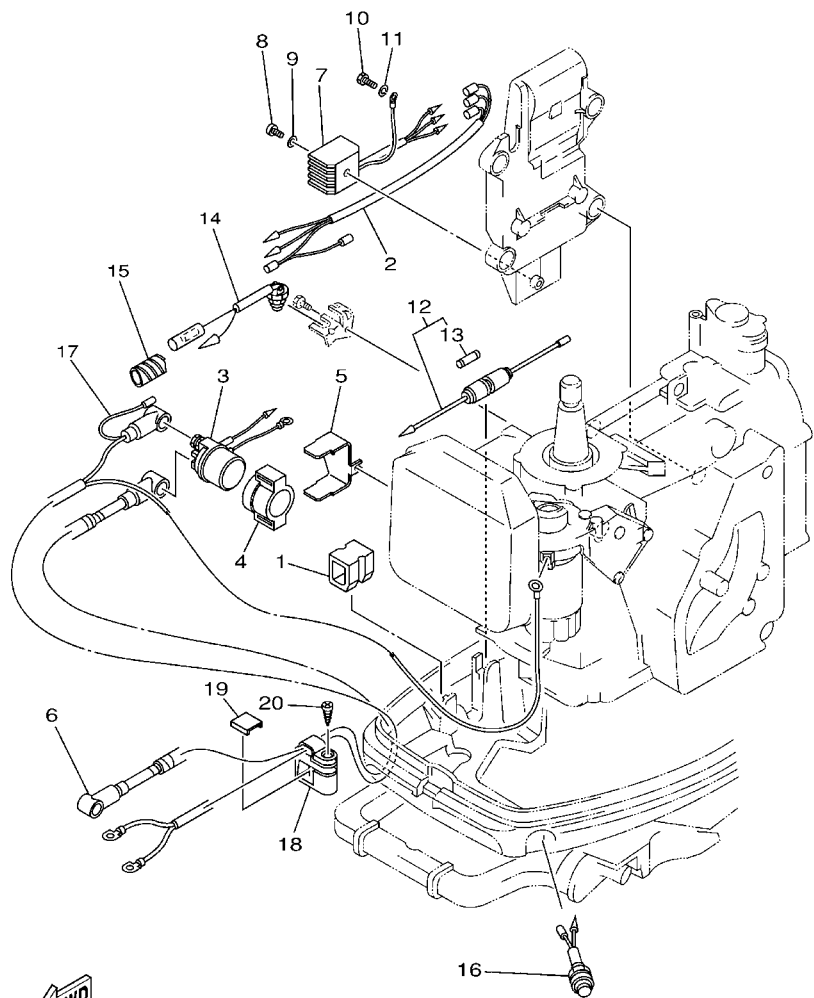

69R0010-1100

REF. NO.	PART NO. CODIGO Nº	DESCRIPTION DESCRIPCION	MH	WH	W	WC	REMARKS OBSERVACIONES
1	90480-17M08	GROMMET TAPON		3			
2	689-81971-00	WIRE, LEAD CABLE CONDUCTOR		1			
3	6G1-81941-10	STARTER RELAY ASSY RELE DE ARRANQUE		1			
4	6G1-81952-00	HOLDER, RELAY SOSTEN DE RELE		1			
5	61T-81945-01	PLATE, SWITCH FITTING PLACA ACCESORIA DE INTERRUPTOR		1			
6	689-82531-02	WIRE, LEAD CABLE CONDUCTOR		1			
7	664-81970-61	RECTIFIER ASSY RECTIFICADOR COMPLETO		1			
8	97880-05025	SCREW, PAN HEAD TORNILLO DE CABEZA CON PLANA		1			
9	92990-05600	WASHER, PLATE ARANDELA PLANA		1			
10	97090-06012	BOLT PERNO		1			
11	92990-06100	WASHER, SPRING ARANDELA PLANA		1			
12	682-82150-10	FUSE HOLDER ASSY PORTA-FUSIBLES COMPLETO		1			
13	663-82151-00	.FUSE (12V-20A) .FUSIBLE (12V-20A)		1			
14	689-82540-01	NEUTRAL SWITCH ASSY INTERRUPTOR NEUTRAL COMPL		1			
15	90446-10M02	HOSE TUBO RESEIRADERO		1			
16	689-81870-00	STARTING SWITCH ASSY INTERRUPTOR DE ARRANQUE COMPL.		1			
17	689-82105-13	WIRE HARNESS ARNES DE CABLES		1			
18	689-82594-00	CLAMP GRAMPA		1			
19	682-42525-00	PLATE, FRICTION PLACA DE FRICCION		1			
20	90161-06M00	SCREW, TAPPING TORNILLO DE CABEZA PLANA		1			

FIG. 11 ELECTRICAL 3

EQUIPO ELECTRICO 3

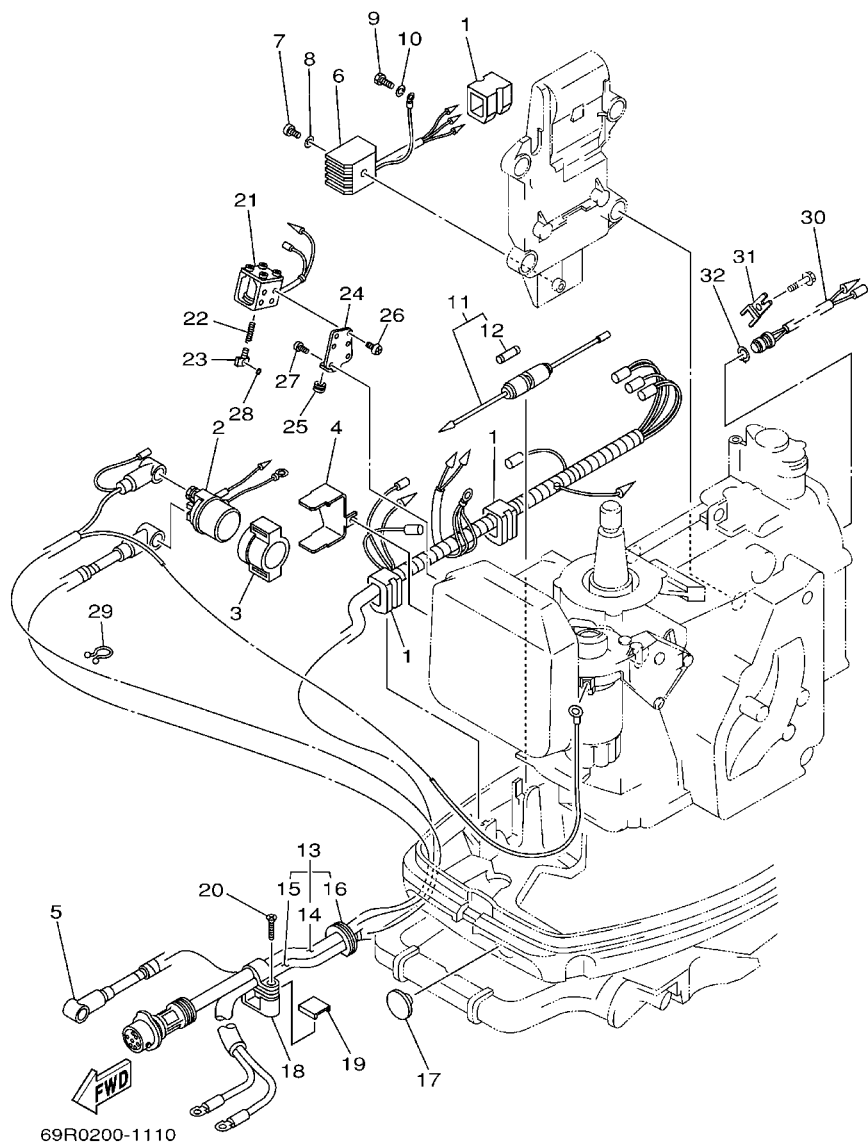

REF. NO.	PART NO. CODIGO Nº	DESCRIPTION DESCRIPCION	MH	WH	W	WC	REMARKS OBSERVACIONES
1	90480-17M08	GROMMET TAPON				3	
2	6G1-81941-10	STARTER RELAY ASSY RELE DE ARRANQUE			1		
3	6G1-81952-00	HOLDER, RELAY SOSTEN DE RELE			1		
4	61T-81945-01	PLATE, SWITCH FITTING PLACA ACCESORIA DE INTERRUPT.			1		
5	689-82531-02	WIRE, LEAD CABLE CONDUCTOR			1		
6	664-81970-61	RECTIFIER ASSY RECTIFICADOR COMPLETO			1		
7	97880-05025	SCREW, PAN HEAD TORNILLO DE CABEZA CON PLANA			1		
8	92990-05600	WASHER, PLATE ARANDELA PLANA			1		
9	97090-06012	BOLT PERNO			1		
10	92990-06100	WASHER, SPRING ARANDELA PLANA			1		
11	682-82150-10	FUSE HOLDER ASSY PORTA-FUSIBLES COMPLETO			1		
12	663-82151-00	.FUSE (12V-20A) .FUSIBLE (12V-20A)			1		
13	61T-82580-00	WIRE HARNESS ASSY 2 CONJUNTO DE CABLES 2			1		
14	61T-82590-00	.WIRE HARNESS ASSY .CONJUNTO DE CABLES			1		
15	689-82105-13	.WIRE HARNESS .ARNES DE CABLES			1		
16	689-42724-50	.GROMMET .TAPON			1		
17	90480-17165	GROMMET TAPON			1		
18	689-82594-10	CLAMP GRAMPA			1		
19	682-42525-00	PLATE, FRICTION PLACA DE FRICCION			1		
20	90161-06M00	SCREW, TAPPING TORNILLO DE CABEZA PLANA			1		
21	61T-86111-00	COIL, SOLENOID CONJUNTO BOBINA SOLENOIDE			1		
22	682-86116-00	WIRE, PULL ALAMBRE-JALADOR			1		
23	682-86117-00	HOOK, WIRE PULL GANCHO JALADOR DE ALAMBRE			1		
24	61T-86112-00	STAY, SOLENOID SOPORTE SOLENOIDE			1		
25	90480-10155	GROMMET TAPON			1		
26	98503-04006	SCREW, PAN HEAD TORNILLO DE CABEZA DE CONO ACH			4		
27	97880-05012	SCREW, PAN HEAD TORNILLO DE CABEZA CON PLANA			2		

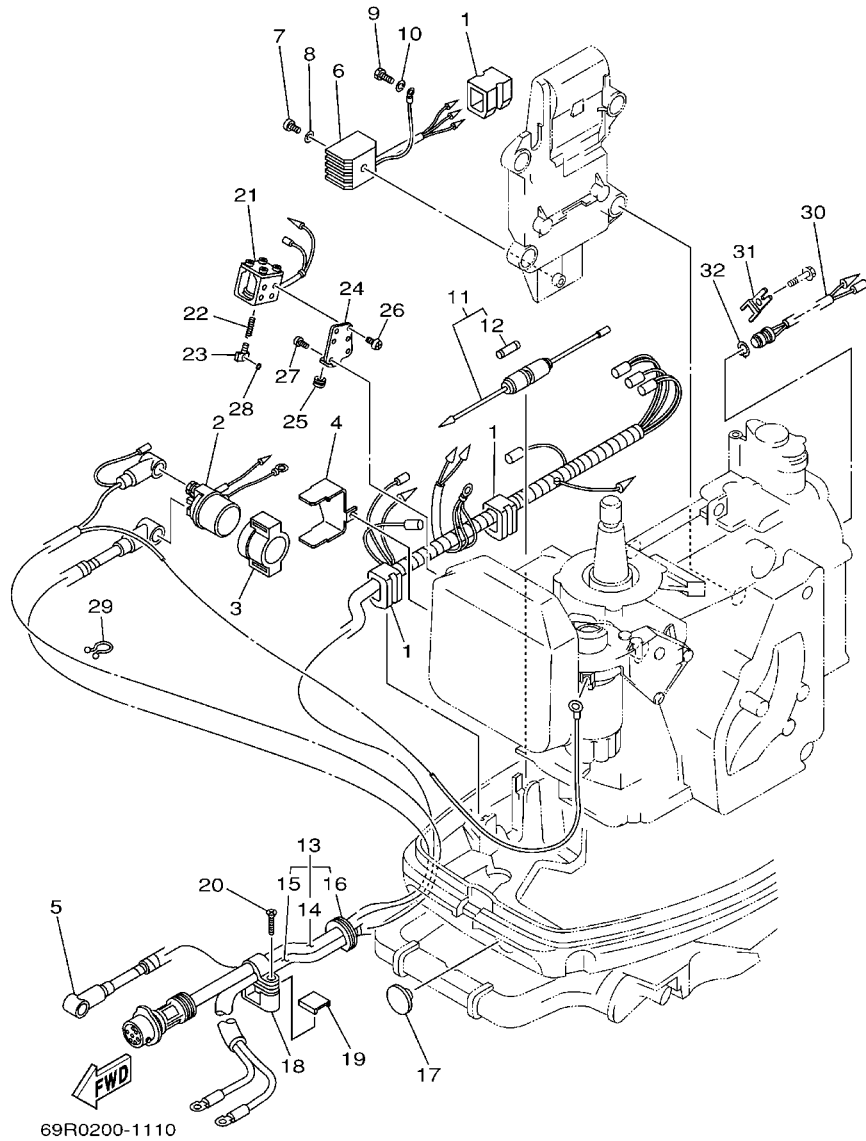

FIG. 11 ELECTRICAL 3

EQUIPO ELECTRICO 3

REF. NO.	PART NO. CODIGO Nº	DESCRIPTION DESCRIPCION	MH	WH	W	WC	REMARKS OBSERVACIONES
28	93210-03261	O-RING ANILLO O				1	
29	90465-18147	CLAMP BRIDA				1	
30	61T-82560-00	THERMO SWITCH ASSY INTER. DE TERMO				1	
31	61T-82588-00	PLATE PLACA				1	
32	99009-17500	CIRCLIP PRESILLA REDONDA				1	

FIG. 12 ELECTRICAL 4

EQUIPO ELECTRICO 4

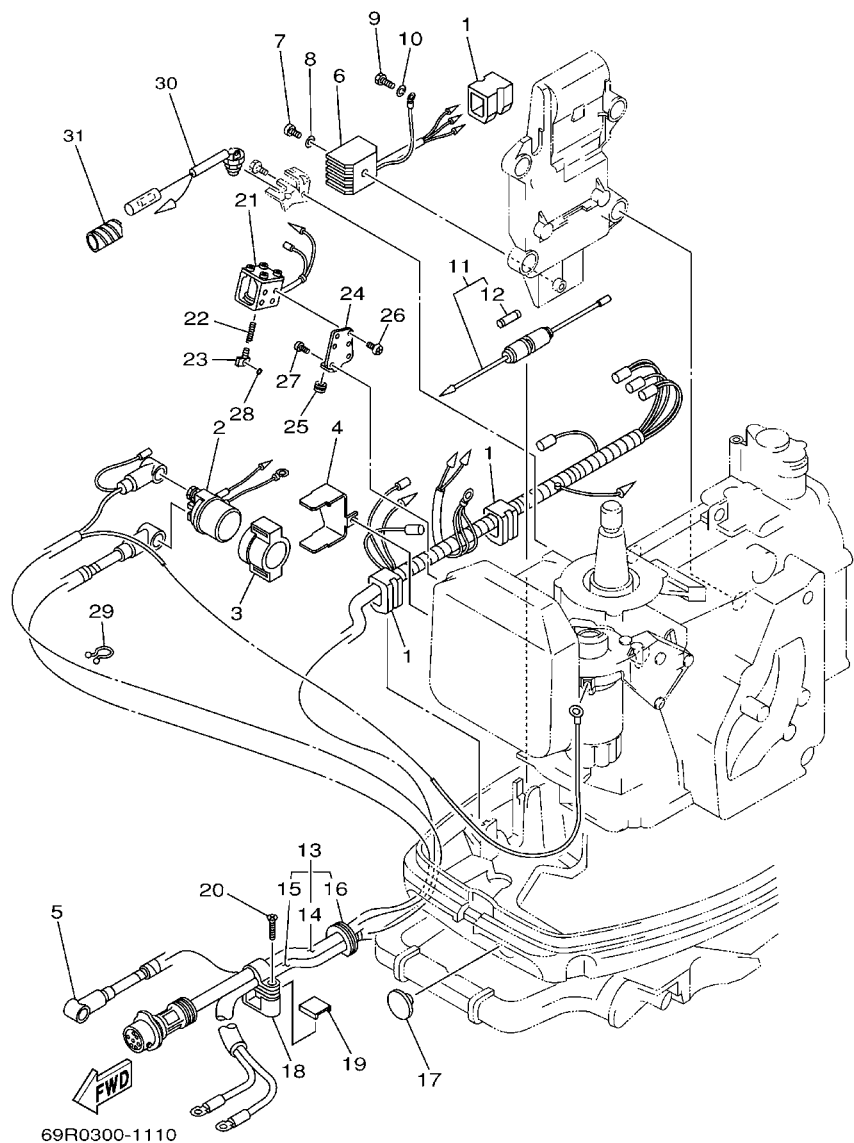

REF. NO.	PART NO. CODIGO Nº	DESCRIPTION DESCRIPCION	MH	WH	W	WC	REMARKS OBSERVACIONES
1	90480-17M08	GROMMET TAPON				3	
2	6G1-81941-10	STARTER RELAY ASSY RELE DE ARRANQUE				1	
3	6G1-81952-00	HOLDER, RELAY SOSTEN DE RELE				1	
4	61T-81945-01	PLATE, SWITCH FITTING PLACA ACCESORIA DE INTERRUPTOR				1	
5	689-82531-02	WIRE, LEAD CABLE CONDUCTOR				1	
6	664-81970-61	RECTIFIER ASSY RECTIFICADOR COMPLETO				1	
7	97880-05025	SCREW, PAN HEAD TORNILLO DE CABEZA CON PLANA				1	
8	92990-05600	WASHER, PLATE ARANDELA PLANA				1	
9	97090-06012	BOLT PERNO				1	
10	92990-06100	WASHER, SPRING ARANDELA PLANA				1	
11	682-82150-10	FUSE HOLDER ASSY PORTA-FUSIBLES COMPLETO				1	
12	663-82151-00	.FUSE (12V-20A) .FUSIBLE (12V-20A)				1	
13	61T-82580-00	WIRE HARNESS ASSY 2 CONJUNTO DE CABLES 2				1	
14	61T-82590-00	.WIRE HARNESS ASSY .CONJUNTO DE CABLES				1	
15	689-82105-13	.WIRE HARNESS .ARNES DE CABLES				1	
16	689-42724-50	.GROMMET .TAPON				1	
17	90480-17165	GROMMET TAPON				1	
18	689-82594-10	CLAMP GRAMPA				1	
19	682-42525-00	PLATE, FRICTION PLACA DE FRICCION				1	
20	90161-06M00	SCREW, TAPPING TORNILLO DE CABEZA PLANA				1	
21	61T-86111-00	COIL, SOLENOID CONJUNTO BOBINA SOLENOIDE				1	
22	682-86116-00	WIRE, PULL ALAMBRE-JALADOR				1	
23	682-86117-00	HOOK, WIRE PULL GANCHO JALADOR DE ALAMBRE				1	
24	61T-86112-00	STAY, SOLENOID SOPORTE SOLENOIDE				1	
25	90480-10155	GROMMET TAPON				1	
26	98503-04006	SCREW, PAN HEAD TORNILLO DE CABEZA DE CONO ACH				4	
27	97880-05012	SCREW, PAN HEAD TORNILLO DE CABEZA CON PLANA				2	

FIG. 12 ELECTRICAL 4

EQUIPO ELECTRICO 4

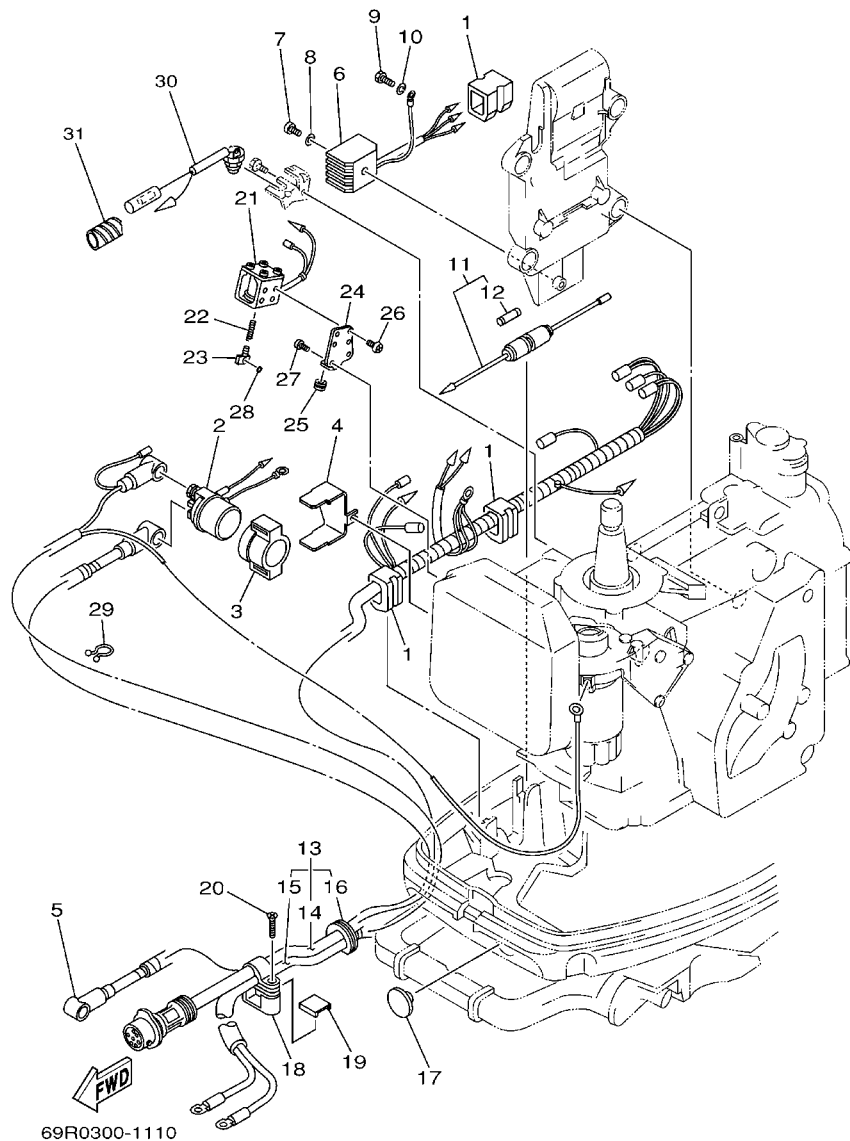

REF. NO.	PART NO. CODIGO Nº	DESCRIPTION DESCRIPCION	MH	WH	W	WC	REMARKS OBSERVACIONES
28	93210-03261	O-RING ANILLO O				1	
29	90465-18147	CLAMP BRIDA				1	
30	689-82540-01	NEUTRAL SWITCH ASSY INTERRUPTOR NEUTRAL COMPL				1	
31	90446-10M02	HOSE TUBO RESEIRADERO				1	

FIG. 13 STARTING MOTOR

MOTOR DE ARRANQUE

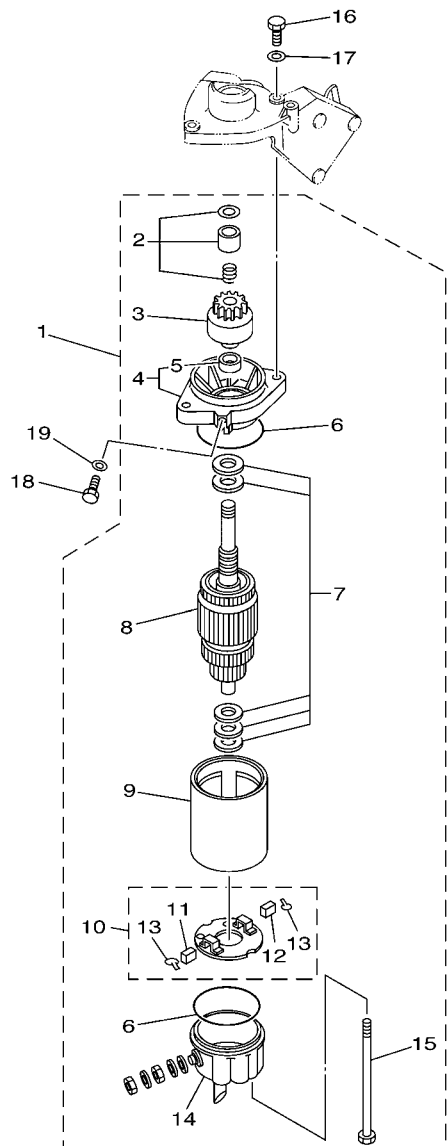

69R3664-3120

REF. NO.	PART NO. CODIGO Nº	DESCRIPTION DESCRIPCION	MH	WH	W	WC	REMARKS OBSERVACIONES
1	689-81800-13	STARTING MOTOR ASSY MOTOR DE ARRANQUE COMPLETO		1	1	1	
2	689-81857-11	.PINION STOPPER SET .JUEGO TAPON PINON		1	1	1	
3	689-81807-12	.GEAR ASSY, STARTING MOTOR .PINON CONJUNTO		1	1	1	
4	689-81830-11	.FRONT BRACKET ASSY .SOPORTE DELANTERO COMPLETO		1	1	1	
5	689-81831-00	..METAL, FRONT ..METAL, DELANTERO		1	1	1	
6	689-81847-11	.O-RING .ANILLO GOMA		2	2	2	
7	689-81809-11	.WASHER KIT .JUEGO DE ARANDELA		1	1	1	
8	689-81850-12	.ARMATURE ASSY .INDUCIDO COMPLETO		1	1	1	
9	689-81810-11	.STATOR ASSY .ESTATOR COMPLETO		1	1	1	
10	689-81840-11	.BRUSH HOLDER ASSY .SOSTEN DE ESCOBILLA COMPLETO		1	1	1	
11	689-81812-11	..BRUSH 2 ..ESCOBILLA 2		1	1	1	
12	689-81811-11	..BRUSH 1 ..ESCOBILLA 1		1	1	1	
13	689-81813-10	..SPRING, BRUSH ..RESORTE DE ESCOBILLA		2	2	2	
14	689-81820-11	.REAR BRACKET ASSY .CUBIERTA TRASERA COMPL		1	1	1	
15	689-81826-10	.BOLT .PERNO		2	2	2	
16	97013-08030	BOLT PERNO		2	2	2	
17	92903-08600	WASHER, PLATE RONDANA SENCILLA		2	2	2	
18	97013-08012	BOLT PERNO		1	1	1	
19	92903-08600	WASHER, PLATE RONDANA SENCILLA		1	1	1	

FIG. 14 BOTTOM COWLING

CUBIERTA INFERIOR

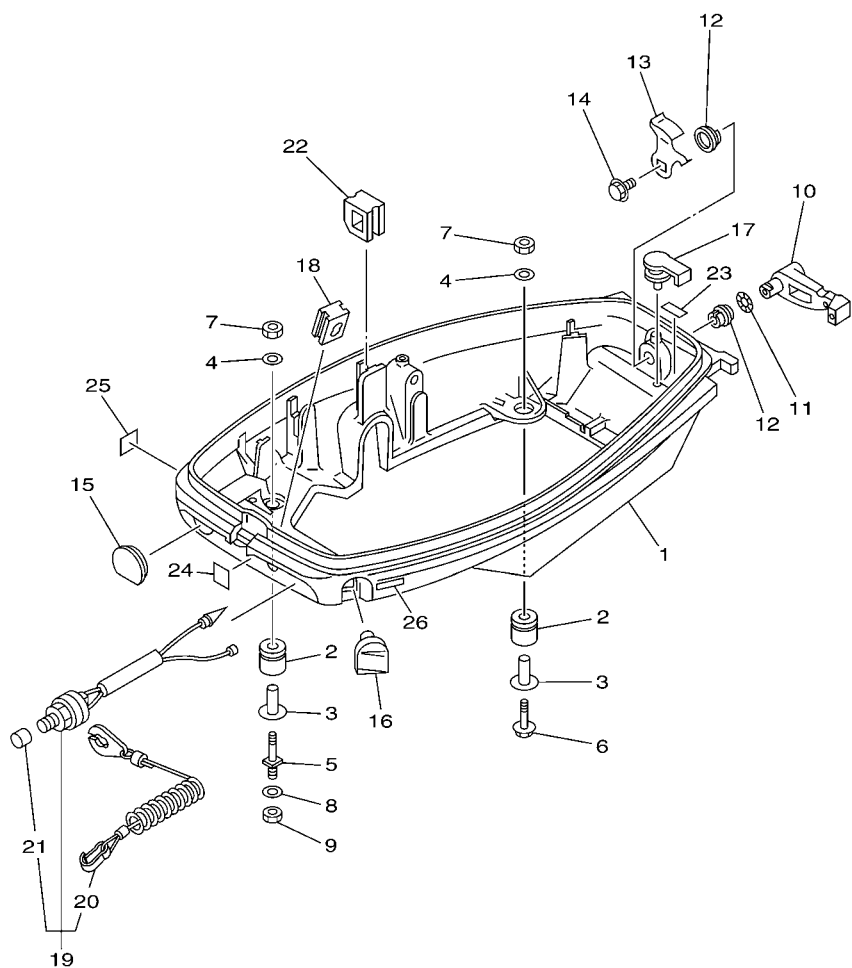

69R6200-E140

REF. NO.	PART NO. CODIGO Nº	DESCRIPTION DESCRIPCION	MH	WH	W	WC	REMARKS OBSERVACIONES
1	689-42711-04-4D	COWLING, BOTTOM 1 CUBIERTA INFERIOR 1	1	1	1	1	
2	90480-15M06	GROMMET TAPON	4	4	4	4	
3	90387-08M25	COLLAR ESPACIADOR	4	4	4	4	
4	90201-08M87	WASHER, PLATE ARANDELA PLANA	4	4	4	4	
5	6G0-42796-00	BOLT 1 TORNILLO	2	2	2	2	
6	97585-08540	BOLT, WITH WASHER PERNO CON ARANDELA	2	2	2	2	
7	95380-08700	NUT TUERCA	4	4	4	4	
8	92990-08600	WASHER, PLATE ARANDELA PLANA	2	2	2	2	
9	95380-08700	NUT TUERCA	2	2	2	2	
10	689-42815-00	LEVER, CLAMP PALANCA ABRAZADERA	1	1	1	1	
11	90206-12052	WASHER, WAVE ARANDELA ONDULADA	1	1	1	1	
12	90386-12069	BUSH BUJE	2	2	2	2	
13	689-42816-00	LEVER, CLAMP PALANCA ABRAZADERA	1	1	1	1	
14	90119-06M73	BOLT, WITH WASHER TORNILLO CON ARANDELA	1	1	1	1	
15	682-42724-00	GROMMET TAPON	1				
	61T-42724-40	GROMMET TAPON		1			
16	689-42725-01	GROMMET TAPON	1		1	1	
17	647-42523-00	SPACER, FRICTION ESPACIADOR DE FRICCION	1	1	1	1	
18	61N-26326-00	GROMMET TAPON PROTECTOR	1	1		1	
	676-42724-40	GROMMET TAPON				1	
19	6E9-82575-02	ENGINE STOP SWITCH ASSY INTERRUPTOR DE PARADA COMPL	1	1			
20	682-82556-00	.LANYARD, STOP SWITCH .RETENER	1	1			
21	689-8257Y-00	.CAP .CASQUILLO	1	1			
22	90480-17M08	GROMMET TAPON	1				
23	6E7-42791-00	MARK 1 MARCA 1	1		1	1	E25B,25B E25B,25B
	6G5-42791-00	MARK 1 MARCA 1	1	1	1	1	E30H,30H E30H,30H
	6E7-42791-10	MARK 1 MARCA 1	1				E25B-FOR CAR E25B-FOR CAR

FIG. 14 BOTTOM COWLING

CUBIERTA INFERIOR

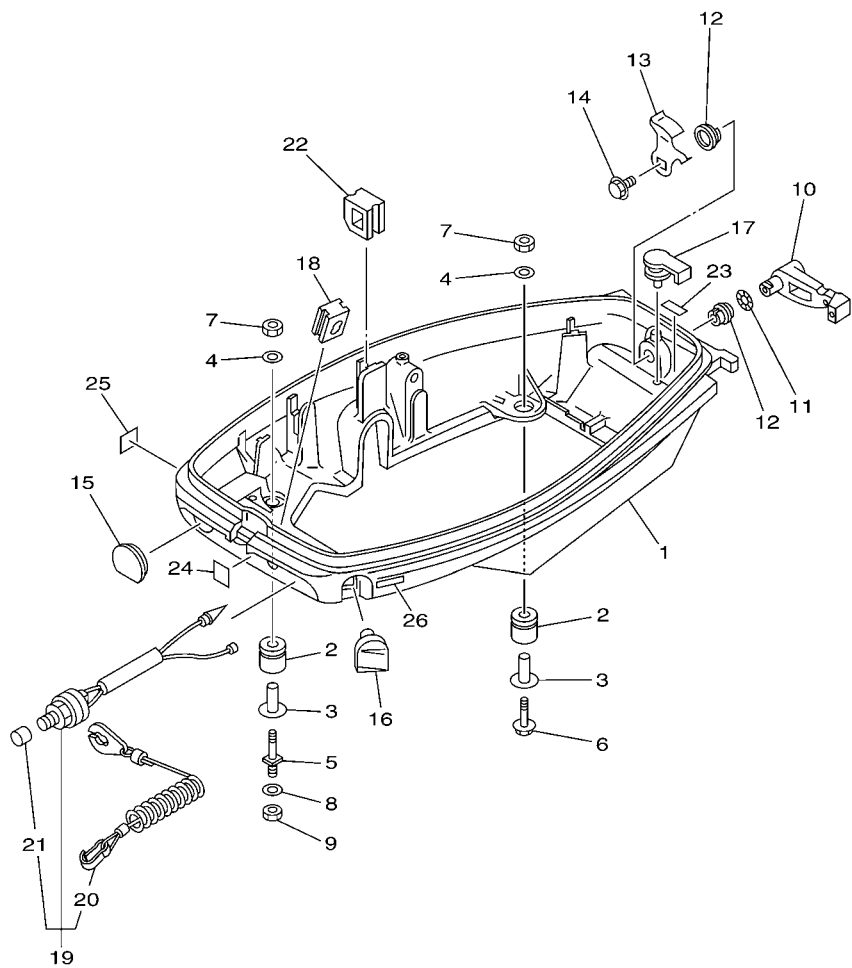

69R6200-E140

REF. NO.	PART NO. CODIGO Nº	DESCRIPTION DESCRIPCION	MH	WH	W	WC	REMARKS OBSERVACIONES
23	6G5-42791-10	MARK 1 MARCA 1	1	1	1		30H-FOR CAR,CHN 30H-FOR CAR,CHN
24	6A1-42792-01	MARK (100:1) MARCA (100:1)	1				30H-FOR CAR 30H-FOR CAR
25	6A1-28176-00	LABEL, CAUTION ETIQUETA DE PRECAUCION	1				E25B,30H-FOR CAR E25B,30H-FOR CAR
26	6E3-8257H-00	PLATE, MARK PLACA DE MARCA	1				E25B,30H-FOR CAR E25B,30H-FOR CAR

FIG. 15 STEERING

DIRECCION

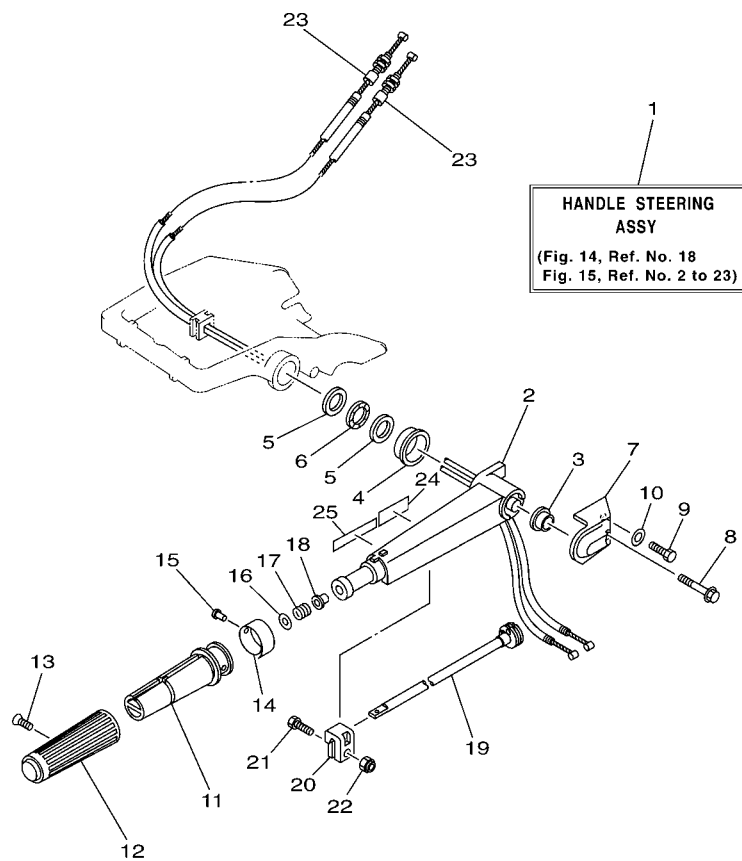

HANDLE STEERING ASSY
(Fig. 14, Ref. No. 18
Fig. 15, Ref. No. 2 to 23)

FWD
69R6200-E150

REF. NO.	PART NO. CODIGO Nº	DESCRIPTION DESCRIPCION	MH	WH	W	WC	REMARKS OBSERVACIONES
1	69P-W0084-00-4D	HANDLE STEERING ASSY CONJUNTO DE MANIJA	1	1		1	
2	689-42111-01-4D	HANDLE, STEERING MANIJA DE DIRECCION	1	1		1	
3	90387-13003	COLLAR ESPACIADOR	1	1		1	
4	90387-33001	COLLAR ESPACIADOR	1	1		1	
5	90201-28013	WASHER, PLATE ARANDELA PLANA	2	2		2	
6	90206-28001	WASHER, WAVE ARANDELA ONDULADA	1	1		1	
7	69P-42112-00-4D	HANDLE, STEERING MANIJA DE DIRRECCION	1	1		1	
8	97595-06550	BOLT, WITH WASHER PERNO CON ARANDELA	1	1		1	
9	97095-06020	BOLT PERNO	1	1		1	
10	92995-06600	WASHER ARANDELA	1	1		1	
11	664-42119-00	GRIP, STEERING HANDLE MANGO, MANIJA DE DIRRECCION	1	1		1	
12	6F6-42177-A0	RUBBER, HANDLE HULE DE MANIJA	1	1		1	
13	90149-05M13	SCREW TORNILLO DE REGLAJE	1	1		1	
14	6G1-42137-10	INDICATOR, THROTTLE INDICADOR ACELERADOR	1	1		1	
15	90269-02M09	RIVET REMACHE	1	1		1	
16	92903-10600	WASHER, PLATE RONDANA SENCILLA	1	1		1	
17	90501-23215	SPRING, COMPRESSION RESORTE DE COMPRESION	1	1		1	
18	90386-08032	BUSH BUJE	1	1		1	
19	689-42138-00	LEVER, THROTTLE PLANCA DE ACELERACION	1	1		1	
20	656-42126-01	FRICTION, STEERING HANDLE GRIP FRICCION DE MANGO DIRECCION	1	1		1	
21	97095-06020	BOLT PERNO	1	1		1	
22	90185-06062	NUT, SELF-LOCKING TUERCA AUTOBLOCANTE	1	1		1	
23	61N-26311-00	CABLE, THROTTLE 1 CABLE DE ACELERADOR 1	2	2		2	
24	61T-83627-80	LABEL, CAUTION 7 ETIQUETA DE PRECAUCION 7	1			1	FOR RUS FOR RUS
25	6E0-83627-41	LABEL, CAUTION 7 ETIQUETA DE PRECAUCION 7	1	1		1	

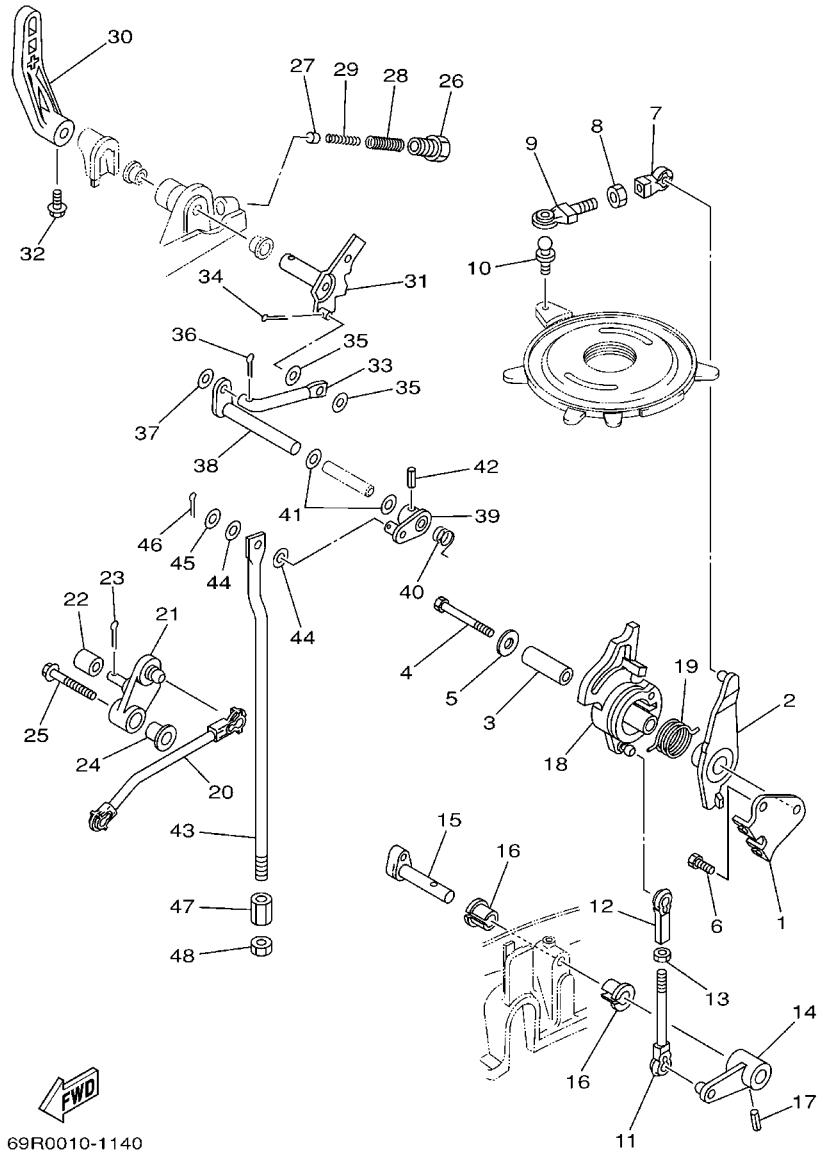

69R0010-1140

FIG. 16 CONTROL 1

CONTROL 1

REF. NO.	PART NO. CODIGO Nº	DESCRIPTION DESCRIPCION	MH	WH	W	WC	REMARKS OBSERVACIONES
1	69P-14497-00	STAY, THROTTLE WIRE SOPORTE VALVULA DE OBTURACION	1	1	1	1	
2	69P-41631-00	LEVER, MAGNETO CONTROL PALANCA DE CONTROL DE MAGNETO	1	1	1	1	
3	90387-06M59	COLLAR ESPACIADOR	1	1	1	1	
4	97095-06045	BOLT PERNO	1	1	1	1	
5	90201-06416	WASHER, PLATE ARANDELA PLANA	1	1	1	1	
6	97095-06012	BOLT PERNO	1	1	1	1	
7	662-41237-01	JOINT, LINK CONECTOR	1	1	1	1	
8	95380-05700	NUT TUERCA	1	1	1	1	
9	679-41241-01	ROD, LINK VARILLA	1	1	1	1	
10	663-85518-00	JOINT, BALL CONECTOR	1	1	1	1	
11	682-41238-01	JOINT, LINK CONECTOR	1	1	1	1	
12	682-41237-00	JOINT, LINK CONECTOR	1	1	1	1	
13	95380-05600	NUT TUERCA	1	1	1	1	
14	69P-42157-00-94	LEVER, THROTTLE PALANCA DE ACELERADOR	1	1	1	1	
15	656-42153-00-94	SHAFT, THROTTLE CONTROL EJE CONTROL DEL ACELERADOR	1	1	1	1	
16	90386-10009	BUSH BUJE	2	2	2	2	
17	91690-40018	PIN, SPRING PASADOR DE RESORTE	1	1	1	1	
18	69P-41213-00	CAM, ACCEL. LEVA ACELERADOR	1	1	1	1	
19	69P-42167-00	SPRING 1 RESORTE 1	1	1	1	1	
20	69P-41241-00	ROD, LINK VARILLA	1	1	1	1	
21	69P-42154-00	LEVER, THROTTLE CONTROL PALANCA CONTROL ACELERADOR	1	1	1	1	
22	62Y-42171-00	BUSHING BUJE	1	1	1	1	
23	91490-16010	PIN, COTTER CHAVETA	1	1	1	1	
24	90387-06M60	COLLAR ESPACIADOR	1	1	1	1	
25	90119-06M17	BOLT, WITH WASHER TORNILLO CON ARANDELA	1	1	1	1	
26	664-42715-00	BUSHING BUJE	1	1	1	1	
27	664-44167-01	PLUNGER, SHIFT CAM EMBOLO DE CAMBIO	1	1	1	1	

D6

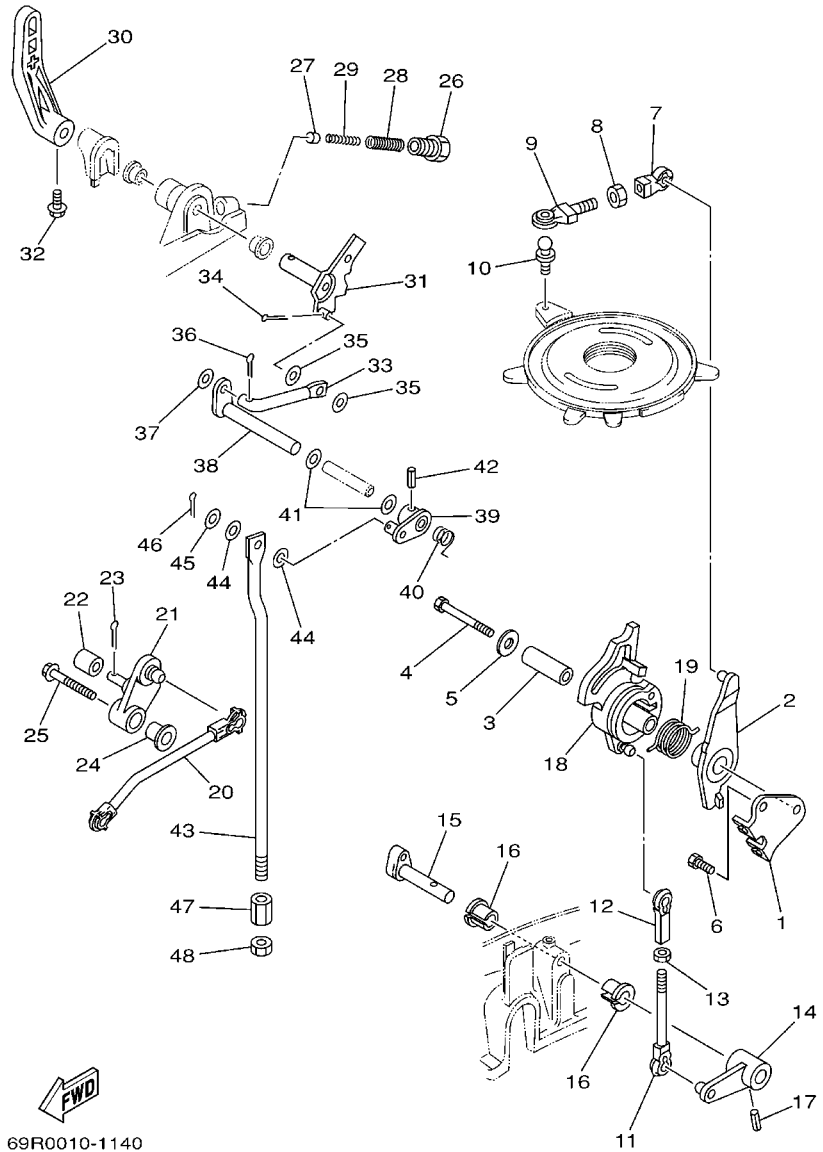

69R0010-1140

FIG. 16 CONTROL 1

CONTROL 1

REF. NO.	PART NO. CODIGO Nº	DESCRIPTION DESCRIPCION	MH	WH	W	WC	REMARKS OBSERVACIONES
28	90501-14M07	SPRING, COMPRESSION RESORTE DE COMPRESION	1	1	1	1	
29	90501-09M08	SPRING, COMPRESSION RESORTE DE COMPRESION	1	1	1	1	
30	689-44111-01-4D	HANDLE, GEAR SHIFT MANIJA DE CAMBIO DE MARCHAS	1	1	1	1	
31	664-44113-01	CAM PLATE, HANDLE PLACA DE LA LEVA DEL MANGO	1	1	1	1	
32	90105-06M07	BOLT, FLANGE TORNILLO	1	1	1	1	
33	664-44142-00	JOINT CONECTOR	1	1	1	1	
34	91490-16010	PIN, COTTER CHAVETA	1	1	1	1	
35	90202-06007	WASHER, PLATE ARANDELA DE PLANA	2	2	2	2	
36	91490-12010	PIN, COTTER CHAVETA	1	1	1	1	
37	92990-05600	WASHER, PLATE ARANDELA PLANA	1	1	1	1	
38	689-44121-01	LEVER, SHIFT ROD PALANCA VARILLA CAMBIOS	1	1	1	1	
39	689-44125-00	LEVER, SHIFT ROD PALANCA VARILLA CAMBIOS	1	1	1	1	
40	90508-14M13	SPRING, TORSION RESORTE DE TORSION	1	1	1	1	
41	90202-10024	WASHER, PLATE ARANDELA DE PLANA	2	2	2	2	
42	91690-40016	PIN, SPRING PASADOR DE RESORTE	1	1	1	1	
43	61N-44143-00	ROD, SHIFT VARILLA DE CAMBIO	1	1	1	1	
44	90202-06007	WASHER, PLATE ARANDELA DE PLANA	2	2	2	2	
45	92990-05600	WASHER, PLATE ARANDELA PLANA	1	1	1	1	
46	91490-20010	PIN, COTTER CHAVETA	1	1	1	1	
47	61N-44146-00	CONNECTOR, SHIFT ROD CONECTOR VARILLA DE CAMBIO	1	1	1	1	
48	95380-06600	NUT, HEXAGON TUERCA	1	1	1	1	

FIG. 17 CONTROL 2

CONTROL 2

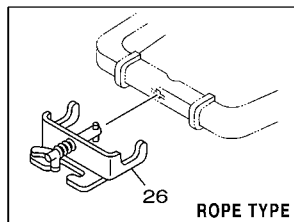
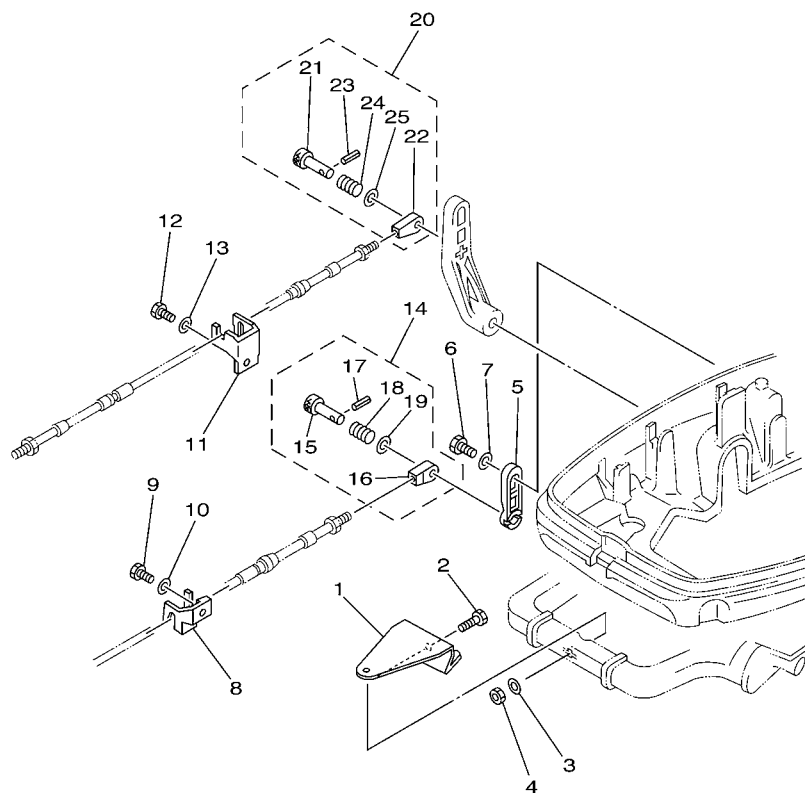

69R3200-3170

REF. NO.	PART NO. CODIGO Nº	DESCRIPTION DESCRIPCION	MH	WH	W	WC	REMARKS OBSERVACIONES
1	689-48511-01	HOOK, STEERING GANCHO DIRECCION				1	
2	97075-10040	BOLT PERNO				1	
3	92990-10600	WASHER, PLATE ARANDELA PLANA				1	
4	90185-10051	NUT, SELF-LOCKING TUERCA AUTOBLOCANTE				1	
5	648-48534-50-4D	THROTTLE LEVER, CONTROL PALANCA DE CONTROL DE ACELERAC				1	1
6	97095-06012	BOLT PERNO				1	1
7	92995-06600	WASHER ARANDELA				1	1
8	689-48532-50	BRACKET, REMOTE CONTROL 2 SOPORTE DE CONTROL REMOTO				1	1
9	97095-06016	BOLT PERNO				1	1
10	92995-06600	WASHER ARANDELA				1	1
11	689-48531-50	BRACKET, REMOTE CONTROL 1 SOPORTE DE CONTROL REMOTO				1	1
12	97095-06016	BOLT PERNO				1	1
13	92995-06600	WASHER ARANDELA				1	1
14	648-48340-50	CABLE END ASSY TERMINAL DE CABLE COMPL.				1	1
15	617-48361-91	.HOOK, CABLE .GANCHO CABLE				1	1
16	617-48346-90	.CABLE END, REMOTE CONTROL .TERMINAL CABLE DE CONTROL REM				1	1
17	91690-30012	.PIN, SPRING .PASADOR DE RESORTE				1	1
18	90501-10264	.SPRING, COMPRESSION .RESORTE DE COMPRESION				1	1
19	92990-08600	.WASHER, PLATE .ARANDELA PLANA				1	1
20	648-48330-50	CABLE END ASSY TERMINAL DE CABLE COMPL.				1	1
21	617-48331-91	.HOOK, CABLE .GANCHO CABLE				1	1
22	648-48346-50	.CABLE END, REMOTE CONTROL .TERMINAL CABLE DE CONTROL REM				1	1
23	91690-30012	.PIN, SPRING .PASADOR DE RESORTE				1	1
24	90501-10071	.SPRING, COMPRESSION .RESORTE DE COMPRESION				1	1
25	92990-08600	.WASHER, PLATE .ARANDELA PLANA				1	1
26	700-48510-12	STEERING HOOK ASSY GANCHO DE DIRECCION COMPL				1	ROPE TYPE ROPE TYPE

FIG. 18 REMO CON ATTACHMENT

CONJUNTO ADITAMENTO

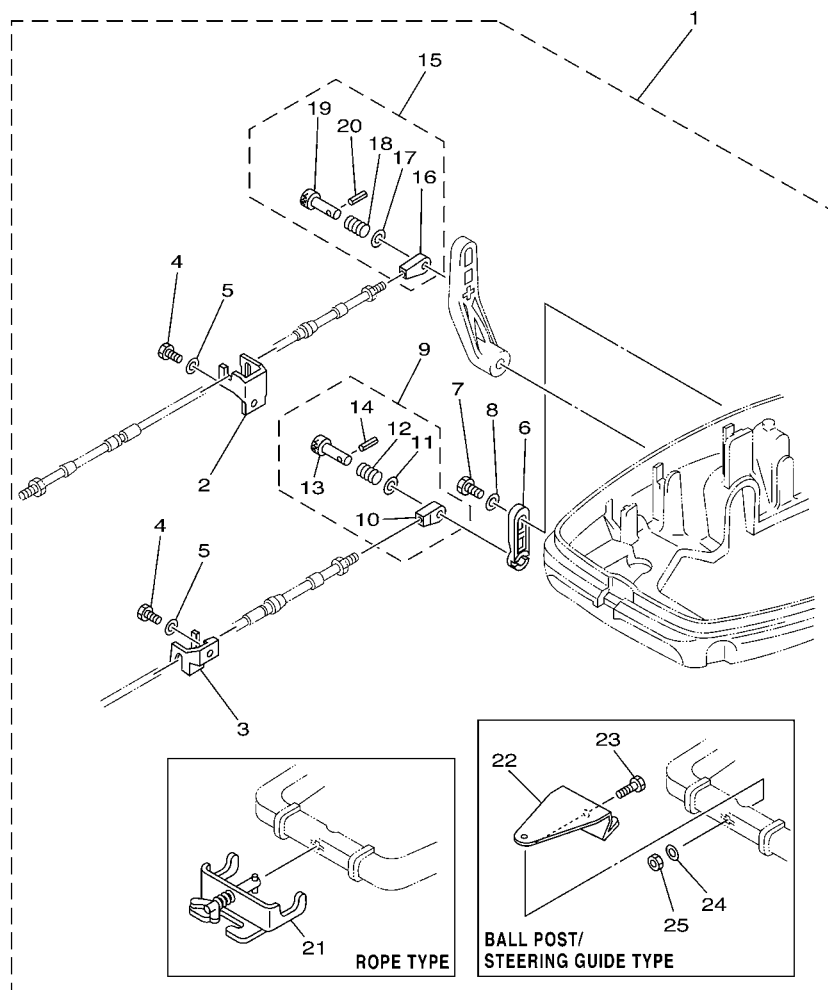

69R3664-3170

REF. NO.	PART NO. CODIGO Nº	DESCRIPTION DESCRIPCION	MH	WH	W	WC	REMARKS OBSERVACIONES
1	689-48501-01-4D	REMOTE CONT. ATTACHMENT ASSY. CONJUNTO ADITAMENTO	1	1	1	1	AP ROPE TYPE
	689-48501-21-4D	REMOTE CONT. ATTACHMENT ASSY. CONJUNTO ADITAMENTO	1	1	1	1	AP ROPE TYPE
2	689-48531-50	.BRACKET, REMOTE CONTROL 1 .SOPORTE DE CONTROL REMOTO	1	1	1	1	AP
3	689-48532-50	.BRACKET, REMOTE CONTROL 2 .SOPORTE DE CONTROL REMOTO	1	1	1	1	AP
4	97095-06016	.BOLT .PERNO	2	2	2	2	
5	92995-06600	.WASHER .ARANDELA	2	2	2	2	
6	648-48534-50-4D	.THROTTLE LEVER, CONTROL .PALANCA DE CONTROL DE ACELERA	1	1	1	1	
7	97095-06012	.BOLT .PERNO	1	1	1	1	
8	92995-06600	.WASHER .ARANDELA	1	1	1	1	
9	648-48340-50	.CABLE END ASSY .TERMINAL DE CABLE COMPL.	1	1	1	1	
10	617-48346-90	..CABLE END, REMOTE CONTROL ..TERMINAL CABLE DE CONTROL RE	1	1	1	1	
11	92990-08600	..WASHER, PLATE ..ARANDELA PLANA	1	1	1	1	
12	90501-10264	..SPRING, COMPRESSION ..RESORTE DE COMPRESION	1	1	1	1	
13	617-48361-91	..HOOK, CABLE ..GANCHO CABLE	1	1	1	1	
14	91690-30012	..PIN, SPRING ..PASADOR DE RESORTE	1	1	1	1	
15	648-48330-50	..CABLE END ASSY .TERMINAL DE CABLE COMPL.	1	1	1	1	
16	648-48346-50	..CABLE END, REMOTE CONTROL ..TERMINAL CABLE DE CONTROL RE	1	1	1	1	
17	92990-08600	..WASHER, PLATE ..ARANDELA PLANA	1	1	1	1	
18	90501-10071	..SPRING, COMPRESSION ..RESORTE DE COMPRESION	1	1	1	1	
19	617-48331-91	..HOOK, CABLE ..GANCHO CABLE	1	1	1	1	
20	91690-30012	..PIN, SPRING ..PASADOR DE RESORTE	1	1	1	1	
21	700-48510-12	.STEERING HOOK ASSY .GANCHO DE DIRECCION COMPL	1	1	1	1	ROPE TYPE
22	689-48511-01	.HOOK, STEERING .GANCHO DIRECCION	1	1	1	1	ROPE TYPE
23	97075-10040	.BOLT .PERNO	1	1	1	1	
24	92990-10600	.WASHER, PLATE ..ARANDELA PLANA	1	1	1	1	
25	90185-10051	.NUT, SELF-LOCKING .TUERCA AUTOBLOCANTE	1	1	1	1	

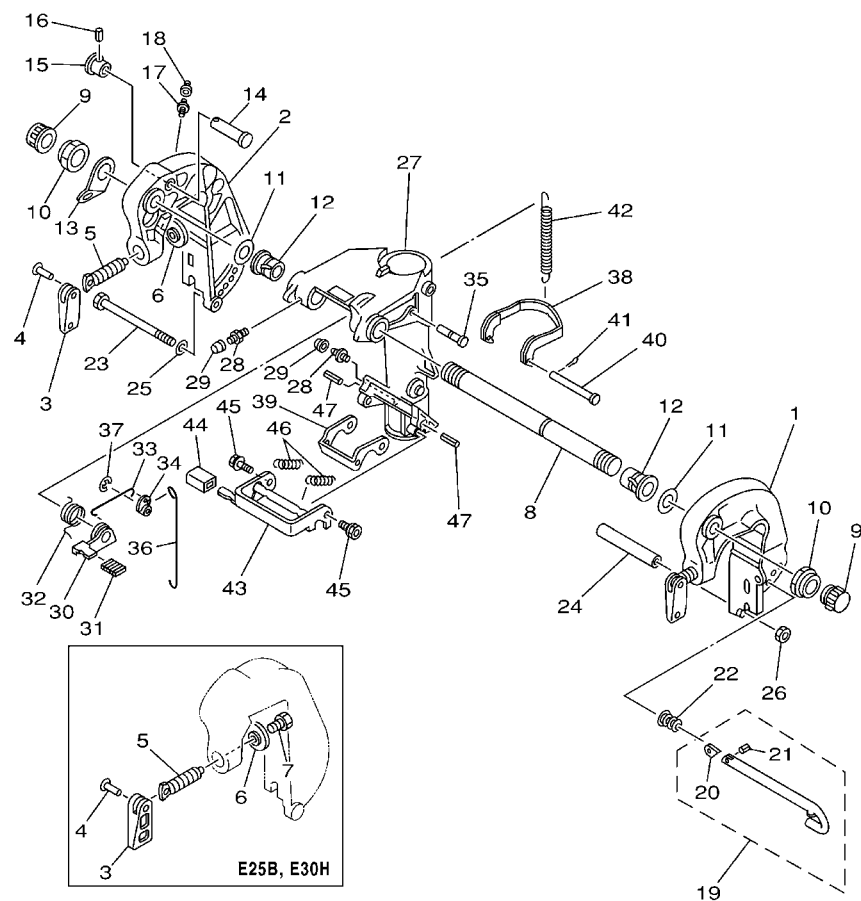

69R2200-2170

FIG. 19 BRACKET 1

SOPORTE 1

REF. NO.	PART NO. CODIGO Nº	DESCRIPTION DESCRIPCION	MH	WH	W	WC	REMARKS OBSERVACIONES
1	689-43111-03-4D	BRACKET, CLAMP 1 SOPORTE DE LA ABRAZADERA 1	1	1	1	1	
2	689-43112-02-4D	BRACKET, CLAMP 2 SOPORTE DE LA ABRAZADERA 2	1	1	1	1	
3	6E0-43118-01	HANDLE, TRANSOM CLAMP MANIJA DE LA ABRAZADERA DEL ES	2	2	2	2	25B,30H 25B,30H
	663-43118-01-4D	HANDLE, TRANSOM CLAMP MANIJA DE LA ABRAZADERA DEL ES	2				E25B,E30H E25B,E30H
4	90243-04M01	PIN PASADOR	2	2	2	2	25B,30H 25B,30H
	90243-04007	PIN PASADOR	2				E25B,E30H E25B,E30H
5	90149-14030	SCREW TORNILLO DE REGLAJE	2	2	2	2	25B,30H 25B,30H
	6G0-43116-00	SCREW, TRANSOM CLAMP TORNILLO DE ABRAZADERA	2				E25B,E30H E25B,E30H
6	648-43114-01	PAD, TRANSOM CLAMP ARANDELA DE ABRAZADERA	2	2	2	2	25B,30H 25B,30H
	6F5-43114-00	PAD, TRANSOM CLAMP ARANDELA DE ABRAZADERA	2				E25B,E30H E25B,E30H
7	90109-06M12	BOLT PERNO	2				E25B,E30H E25B,E30H
8	6J8-43131-01	BOLT, CLAMP BRACKET TORNILLO DE ABRAZADERA DEL SOP	1	1	1	1	
9	6G5-43145-01	CAP, CLAMP BRACKET TAPA	2	2	2	2	
10	90185-22043	NUT, SELF-LOCKING TUERCA AUTOBLOCANTE	2	2	2	2	
11	90201-22M03	WASHER, PLATE ARANDELA PLANA	2	2	2	2	
12	90386-22M67	BUSH BUJE	2	2	2	2	
13	6J8-43113-01	PLATE, CLAMP BRACKET PLACA ABRAZADERA SOPORTE	1	1	1	1	
14	689-43191-00	SHAFT, STOPPER EJE DE TOPE	1	1	1	1	
15	689-43192-01	KNOB, STOPPER PERILLA DE TOPE	1	1	1	1	
16	91690-30016	PIN, SPRING PASADOR DE RESORTE	1	1	1	1	
17	93700-06M03	NIPPLE, GREASE BOQUILLA DE ENGRASAR	1	1	1	1	
18	663-45119-00	CAP, GREASE NIPPLE TAPA DE GRASERA	1	1	1	1	AP AP
19	689-43160-00	TILT ROD ASSY VARILLA DE BASCULACION COMPL.	1	1	1	1	
20	689-43165-00	.PLATE, TILT LOCK .PLACA DE TOPE, VARILLA SEGUR	1	1	1	1	
21	91690-30008	.PIN, SPRING .PASADOR DE RESORTE	1	1	1	1	
22	90502-10M07	SPRING, CONICAL RESORTE CONICO	1	1	1	1	
23	90101-08339	BOLT TORNILLO	1	1	1	1	

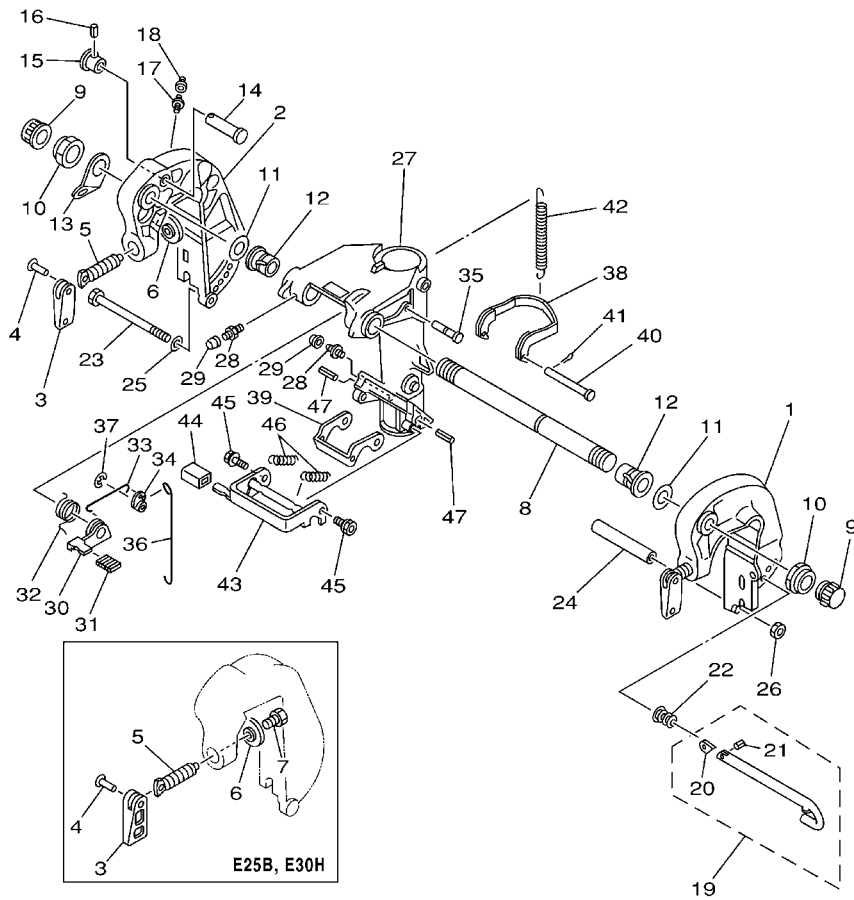

69R2200-2170

FIG. 19 BRACKET 1

SOPORTE 1

REF. NO.	PART NO. CODIGO Nº	DESCRIPTION DESCRIPCION	MH	WH	W	WC	REMARKS OBSERVACIONES
24	90387-08M03	COLLAR ESPACIADOR	1	1	1	1	
25	92990-08600	WASHER, PLATE ARANDELA PLANA	1	1	1	1	
26	95380-08600	NUT TUERCA	1	1	1	1	
27	689-43311-03-4D	BRACKET, SWIVEL 1 SOPORTE GIRATORIO 1	1	1	1	1	
28	93700-06M03	NIPPLE, GREASE BOQUILLA DE ENGRASAR	3	3	3	3	
29	663-45119-00	CAP, GREASE NIPPLE TAPA DE GRASERA	3	3	3	3	AP AP
30	689-43631-00	LEVER, TILT PALANCA DE INCLINACION	1	1	1	1	
31	689-43633-00	COVER, TILT LEVER CUBIERTA PALANCA DE INCLINACION	1	1	1	1	
32	689-43643-00	SPRING RESORTE	1	1	1	1	
33	689-43616-00	ROD, TILT LOCK VARILLA SEGURO DE INCLINACION	1	1	1	1	
34	648-43642-00	LEVER, TILT 1 PALANCA DE INCLINACION 1	1	1	1	1	
35	90249-06M22	PIN PASADOR	1	1	1	1	
36	648-43617-00	ROD, TILT LOCK VARILLA SEGURO DE INCLINACION	1	1	1	1	
37	99080-05600	CIRCLIP PRESILLA REDONDA	1	1	1	1	
38	689-43614-01	PLATE, TILT LOCK PLACA DE SEGURO DE INCLINACION	1	1	1	1	
39	648-43615-00	PLATE, TILT LOCK PLACA DE SEGURO DE INCLINACION	1	1	1	1	
40	90240-05047	PIN, CLEVIS PASADOR CON HOYO	1	1	1	1	
41	91490-16010	PIN, COTTER CHAVETA	1	1	1	1	
42	90506-30M27	SPRING, TENSION RESORTE DE TENSION	1	1	1	1	
43	689-43681-01	LEVER, SHALLOW WATER DRIVE 1 PALANCA 1	1	1	1	1	EXCEPT 30HW-RUS EXCEPT 30HW-RUS
44	682-43318-01	COVER CUBIERTA	1	1	1	1	EXCEPT 30HW-RUS EXCEPT 30HW-RUS
45	90109-06M18	BOLT PERNO	2	2	2	2	EXCEPT 30HW-RUS EXCEPT 30HW-RUS
46	90506-16M17	SPRING, TENSION RESORTE DE TENSION	2	2	2	2	EXCEPT 30HW-RUS EXCEPT 30HW-RUS
47	91690-40035	PIN, SPRING PASADOR DE RESORTE	2	2	2	2	EXCEPT 30HW-RUS EXCEPT 30HW-RUS

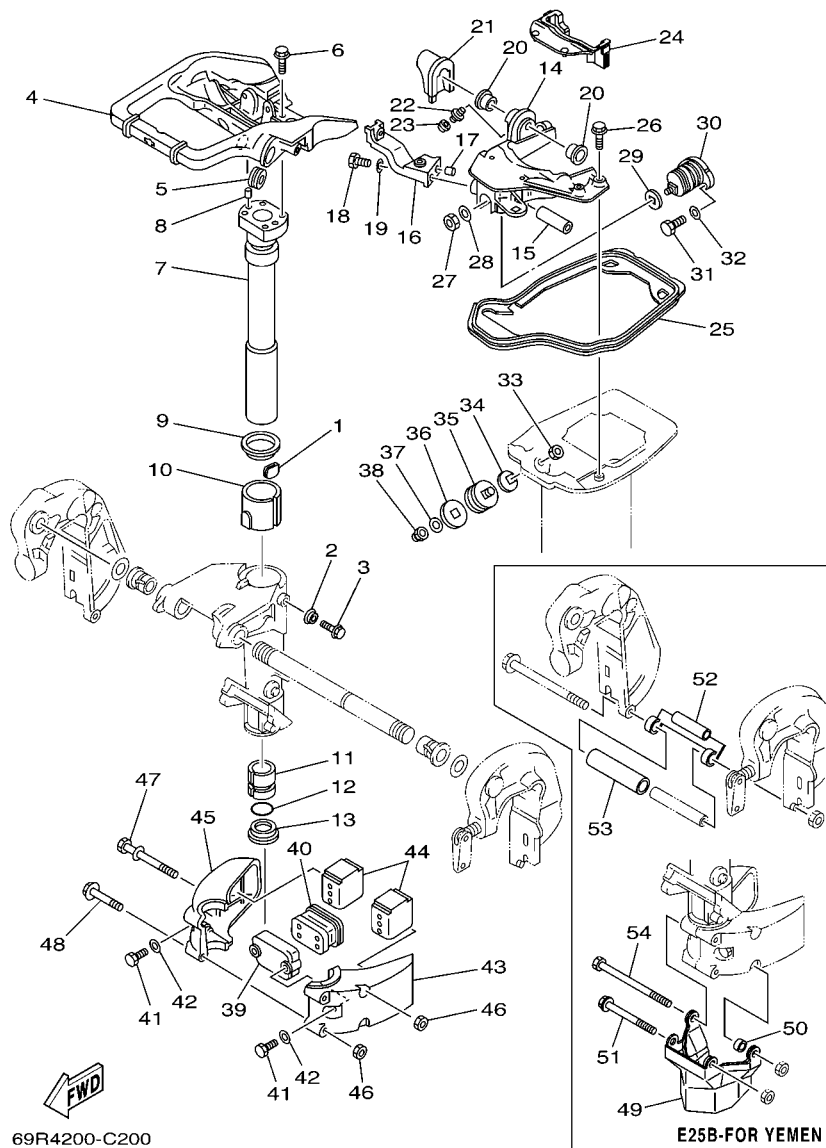

FIG. 20 BRACKET 2

SOPORTE 2

REF. NO.	PART NO. CODIGO Nº	DESCRIPTION DESCRIPCION	MH	WH	W	WC	REMARKS OBSERVACIONES
1	648-42528-00	PLATE, FRICTION PIEZA DE FRICCION	1	1	1	1	
2	689-43373-01	SEAL, DAMPER SELLO DE GOMA	1	1	1	1	
3	90105-06M18	BOLT, FLANGE TORNILLO	1	1	1	1	
4	69P-42511-00-4D	BRACKET, STEERING SOPORTE DE DIRECCION	1	1	1	1	
5	90480-29045	GROMMET TAPON	1	1		1	
6	90105-06M07	BOLT, FLANGE TORNILLO	4	4	4	4	
7	689-42521-00-94	SHAFT, STEERING PIVOT EJE PIVOTE DE DIRECCION	1	1	1	1	
8	93608-12063	PIN, DOWEL PASADOR DE CLAVIJA	2	2	2	2	
9	90209-47016	WASHER ARANDELA DE SEPARACION	1	1	1	1	
10	90386-47M22	BUSH BUJE	1	1	1	1	
11	90386-38090	BUSH BUJE	1	1	1	1	
12	93210-37160	O-RING ANILLO O	1	1	1	1	
13	90386-38022	BUSH BUJE	1	1	1	1	
14	69P-44518-00-94	BRACKET COMP. SOPORTE	1	1	1	1	
15	90387-10M39	COLLAR ESPACIADOR	1	1	1	1	
16	648-44519-00-94	BRACKET SOPORTE	1	1	1	1	
17	93606-12019	PIN, DOWEL PASADOR DE CLAVIJA	1	1	1	1	
18	97095-06018	BOLT PERNO	1	1	1	1	
19	92995-06600	WASHER ARANDELA	1	1	1	1	
20	90381-12M01	BUSH, SOLID BUJE SOLIDO	2	2	2	2	
21	689-42718-00	RUBBER, SEAL 3 GOMA	1	1	1	1	
22	93700-06M03	NIPPLE, GREASE BOQUILLA DE ENGRASAR	1	1	1	1	
23	663-45119-00	CAP, GREASE NIPPLE TAPA DE GRASERA	1	1	1	1	AP AP
24	69P-42717-00	RUBBER, SEAL 2 GOMA	1	1	1	1	
25	69P-42716-00	RUBBER, SEAL 1 SELLO DE GOMA 1	1	1	1	1	
26	90105-06M08	BOLT, FLANGE TORNILLO	4	4	4	4	
27	90170-10M42	NUT TUERCA	1	1	1	1	

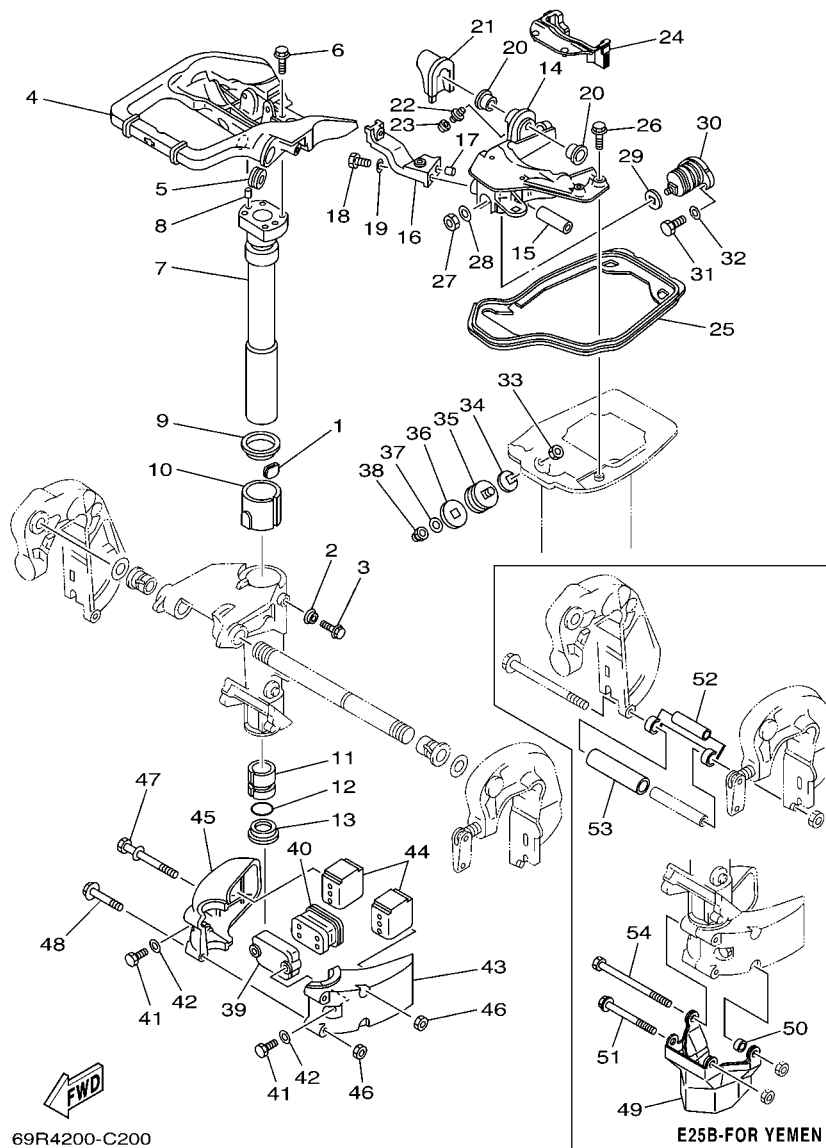

FIG. 20 BRACKET 2

SOPORTE 2

REF. NO.	PART NO. CODIGO Nº	DESCRIPTION DESCRIPCION	MH	WH	W	WC	REMARKS OBSERVACIONES
28	92990-10200	WASHER, PLAIN ARANDELA PLANA	1	1	1	1	
29	648-44591-A0	GASKET EMPAQUE, AMORTIGUADOR	1	1	1	1	
30	689-44516-00	MOUNT DAMPER, UPPER FRONT AMORTIGUADOR DE HULE FRENTE SU	1	1	1	1	
31	97095-06020	BOLT PERNO	2	2	2	2	
32	92995-06600	WASHER ARANDELA	2	2	2	2	
33	90170-10M42	NUT TUERCA	2	2	2	2	
34	648-44591-A0	GASKET EMPAQUE, AMORTIGUADOR	2	2	2	2	
35	664-44514-00-94	MOUNT DAMPER, UPPER SIDE AMORTIGUADOR LADO SUPERIOR	2	2	2	2	
36	664-44591-A0	GASKET EMPAQUE, AMORTIGUADOR	2	2	2	2	
37	92990-10200	WASHER, PLAIN ARANDELA PLANA	2	2	2	2	
38	90176-10M01	NUT, CROWN TUERCA CORONA	2	2	2	2	
39	689-44553-00-94	COVER, LOWER MOUNT CUBIERTA, AMORTIGUADOR INFERIOR	1	1	1	1	
40	689-44557-00	MOUNT DAMPER, LOWER FRONT AMORTIGUADOR DE HULE FRENTE IN	1	1	1	1	
41	97075-08025	BOLT PERNO	2	2	2	2	
42	92995-08600	WASHER ARANDELA	2	2	2	2	
43	689-44551-01-4D	HOUSING, LOWER MOUNT RUBBER CAJA AMORTIGUADOR INFERIOR HU	1	1	1	1	
44	689-44555-00	MOUNT DAMPER, LOWER SIDE AMORTIGUADOR DE HULE LADO INFE	2	2	2	2	
45	689-44552-01-4D	HOUSING, LOWER MOUNT RUBBER CAJA AMORTIGUADOR INFERIOR HU	1	1	1	1	
46	95380-08600	NUT TUERCA	4	4	4	4	
47	90119-08M03	BOLT, WITH WASHER TORNILLO CON ARANDELA	2	2	2	2	
	90119-08M03	BOLT, WITH WASHER TORNILLO CON ARANDELA	1				E25B-FOR YEM E25B-FOR YEM
48	97595-08565	BOLT, WITH WASHER PERNO CON ARANDELA	2	2	2	2	
	97595-08565	BOLT, WITH WASHER PERNO CON ARANDELA	1				E25B-FOR YEM E25B-FOR YEM
49	69P-45151-00	COVER, UPPER CASING CUBIERTA FUNDA SUPERIOR	1				E25B-FOR YEM E25B-FOR YEM E25B-FOR YEM
50	90387-08019	COLLAR ESPACIADOR	1				E25B-FOR YEM E25B-FOR YEM
51	90119-08061	BOLT, WITH WASHER TORNILLO CON ARANDELA	1				E25B-FOR YEM E25B-FOR YEM
52	69P-43625-00	PLATE, TILT ROCK 4 PLACA DE SEGURO DE INCLINACION	1				E25B-FOR YEM E25B-FOR YEM

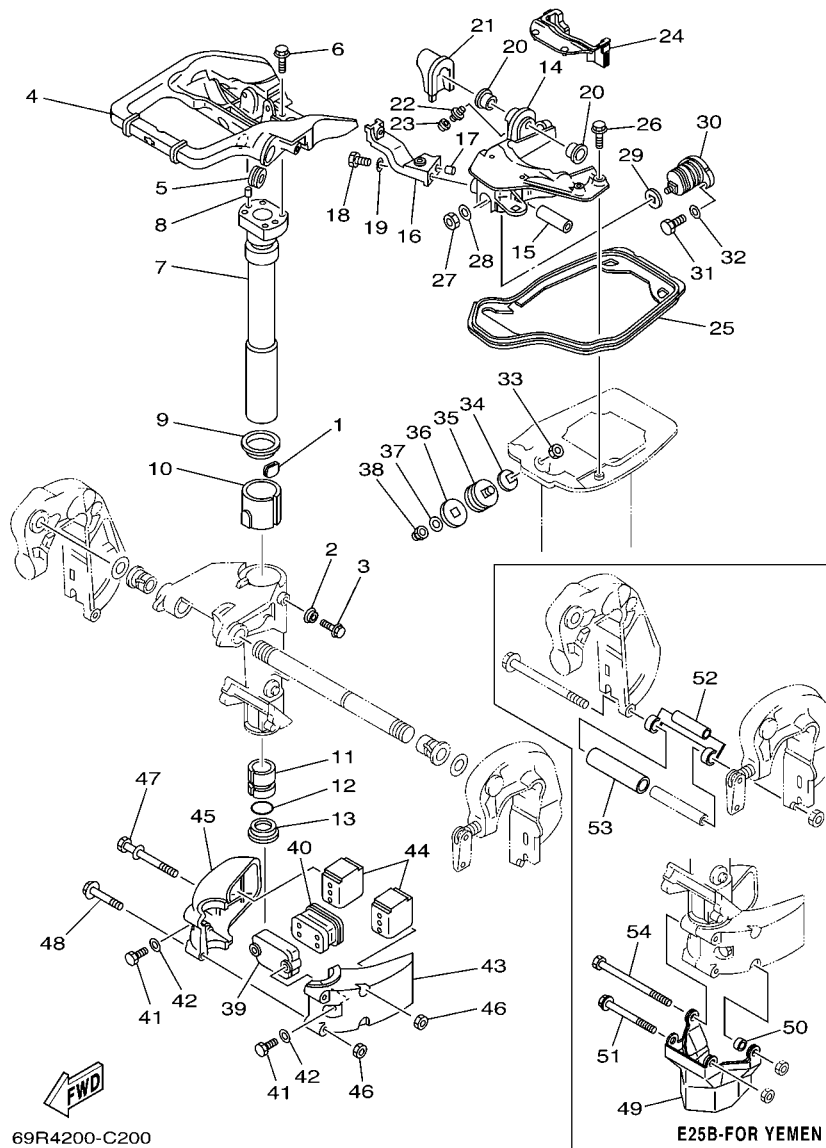

FIG. 20 BRACKET 2

SOPORTE 2

REF. NO.	PART NO. CODIGO Nº	DESCRIPTION DESCRIPCION	MH	WH	W	WC	REMARKS OBSERVACIONES
53	90445-22002	HOSE (L82) MANGUERA (L82)	1				E25B-FOR YEM E25B-FOR YEM
54	97095-08110	BOLT PERNO	1				E25B-FOR YEM E25B-FOR YEM

FIG. 21 UPPER CASING

FUNDA SUPERIOR

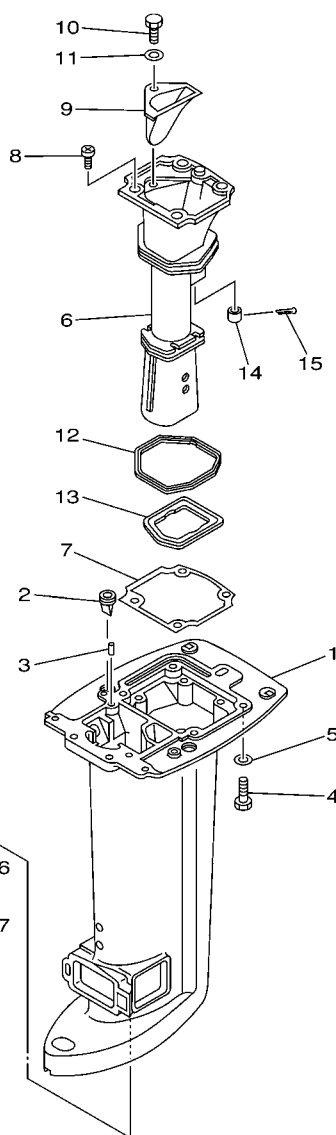
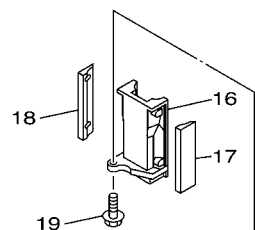
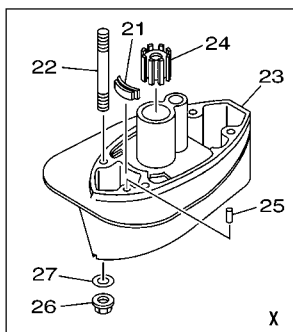
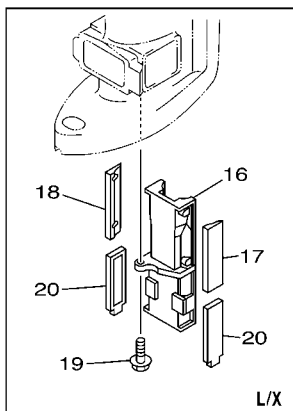

69R3200-3210

REF. NO.	PART NO. CODIGO Nº	DESCRIPTION DESCRIPCION	MH	WH	W	WC	REMARKS OBSERVACIONES
1	69P-45111-00-4D	CASING, UPPER CAJA SUPERIOR	1		1	1	S(16.7") S(16.7")
	69P-45111-10-4D	CASING, UPPER CAJA SUPERIOR	1	1	1		L(21.6"),X(25.0") L(21.6"),X(25.0")
2	65W-42717-00	RUBBER, SEAL 2 GOMA	2	2	2	2	
3	93606-12019	PIN, DOWEL PASADOR DE CLAVIJA	2	2	2	2	
4	97075-08030	BOLT PERNO	6	6	6	6	
5	92995-08600	WASHER ARANDELA	6	6	6	6	
6	69P-41131-01-5B	MANIFOLD, EXT. 1 TUBO MULTIPLE DE ESCAPE	1	1	1	1	FOR STD FOR STD
	69P-41131-11-5B	MANIFOLD, EXT. 1 TUBO MULTIPLE DE ESCAPE	1	1	1		
7	69P-41134-A0	GASKET, EXHAUST MANIFOLD EMPAQUE	1	1	1	1	
8	97880-06016	SCREW, PAN HEAD TORNILLO DE CABEZA CON PLANA	4	4	4	4	
9	69P-41137-00-5B	GUIDE, EXHAUST GUIA DE ESCAPE	1	1	1	1	
10	97095-08020	BOLT PERNO	1	1	1	1	
11	92995-08600	WASHER ARANDELA	1	1	1	1	
12	69P-41138-00	SEAL, EXT. 1 SELLO, ESCAPE 1	1	1	1	1	
13	69P-41139-00	SEAL, EXT. 2 SELLO, ESCAPE 2	1	1	1	1	
14	6A8-41135-00	GASKET, EXHAUST MANIFOLD EMPAQUE	1	1	1	1	
15	91490-30025	PIN, COTTER CHAVETA	1	1	1	1	
16	69P-47467-00-5B	PLATE, GUIDE PLACA DE GUIA	1		1	1	S(16.7") S(16.7")
	69P-47467-10-5B	PLATE, GUIDE PLACA DE GUIA	1	1	1		L(21.6"),X(25.0") L(21.6"),X(25.0")
17	69P-45127-00	SEAL SELLO DE GOMA	1	1	1	1	
18	69P-45128-00	SEAL 2 SELLO DE GOMA 2	1	1	1	1	
19	90119-06024	BOLT, WITH WASHER TORNILLO CON ARANDELA	1	1	1	1	
20	69P-45159-00	DAMPER SELLO DE GOMA	2	2	2		L(21.6"),X(25.0") L(21.6"),X(25.0")
21	61N-45375-00	DAMPER, SEAL GOMA DE SELLO	1				X(25.0") X(25.0")
22	90116-10M33	BOLT, STUD ESPARRAGO	4				X(25.0") X(25.0")
23	61N-45211-31-4D	EXTENSION EXTENSION	1				X(25.0") X(25.0")
24	689-45318-00	BUSHING, DRIVE SHAFT BUJE, EJE DE MANDO	1				X(25.0") X(25.0")

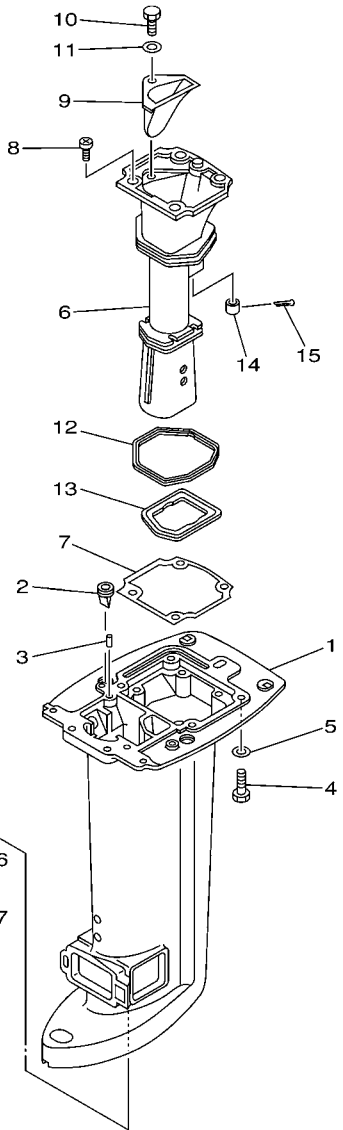
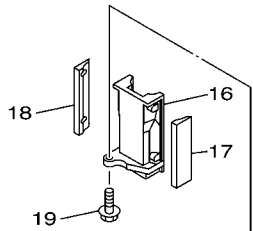
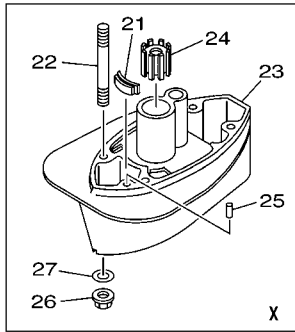
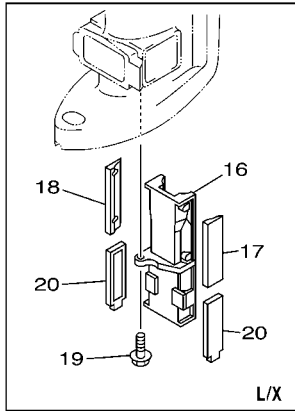

FIG. 21 UPPER CASING

FUNDA SUPERIOR

REF. NO.	PART NO. CODIGO Nº	DESCRIPTION DESCRIPCION	MH	WH	W	WC	REMARKS OBSERVACIONES
25	93606-11M24	PIN, DOWEL PASADOR DE CLAVIJA	2				X(25.0") X(25.0")
26	90179-10M03	NUT TUERCA	4				X(25.0") X(25.0")
27	92995-10600	WASHER ARANDELA	4				X(25.0") X(25.0")

 69R3200-3210

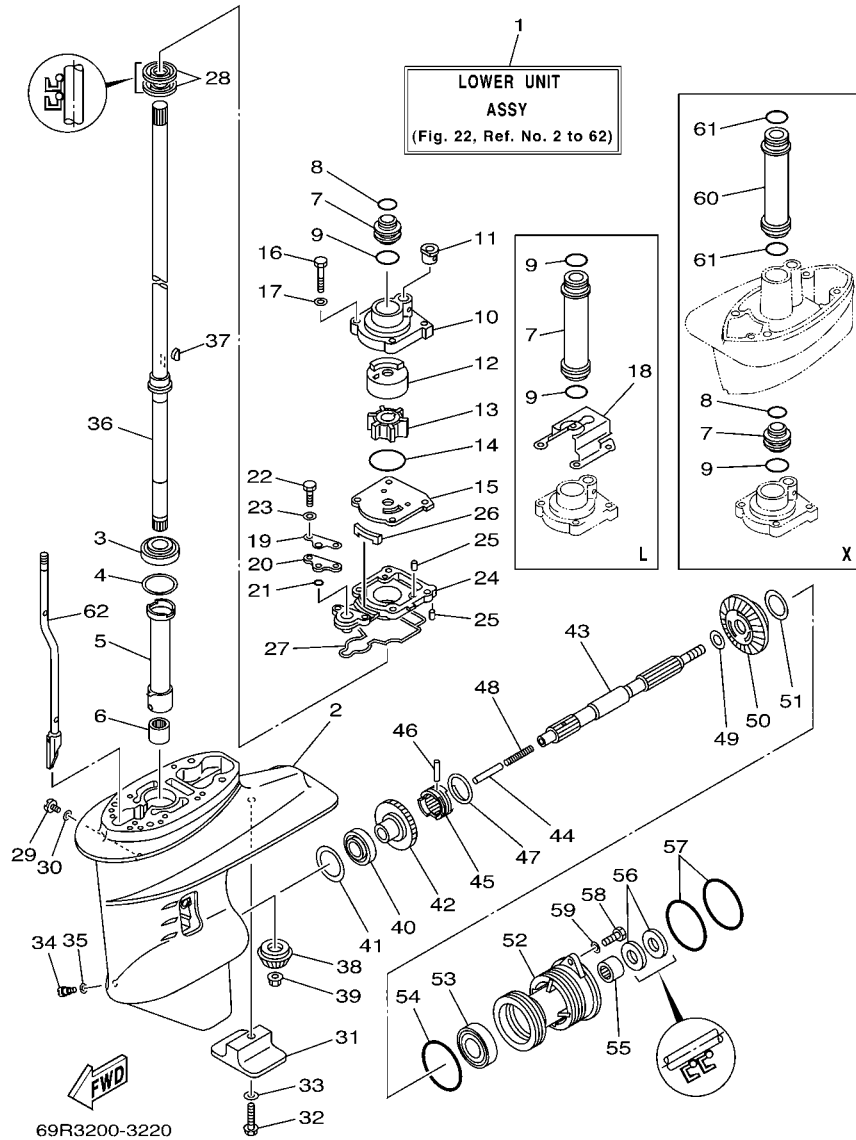

FIG. 22 LOWER CASING & DRIVE 1 IMPULSOR E INFERIOR 1

REF. NO.	PART NO. CODIGO Nº	DESCRIPTION DESCRIPCION	MH	WH	W	WC	REMARKS OBSERVACIONES
1	69P-45300-01-4D	LOWER UNIT ASSY CONJUNTO UNIDAD INFERIOR	1		1	1	S(16.7") S(16.7")
	69P-45300-11-4D	LOWER UNIT ASSY CONJUNTO UNIDAD INFERIOR	1	1	1		L(21.6") L(21.6")
	69P-45300-31-4D	LOWER UNIT ASSY CONJUNTO UNIDAD INFERIOR	1				X(25.0") X(25.0")
2	61N-45311-02-4D	CASING, LOWER FUNDA INFERIOR	1	1	1	1	
3	93332-000W5	BEARING COJINETE	1	1	1	1	
4	61N-45587-00	SHIM (T:0.7MM) LAINA (T:0.7MM)	1	1	1	1	UR
	61N-45587-10	SHIM (T:1.0MM) LAINA (T:1.0MM)	1	1	1	1	UR
	61N-45587-20	SHIM (T:1.1MM) LAINA (T:1.1MM)	1	1	1	1	UR
	61N-45587-30	SHIM (T:1.2MM) LAINA (T:1.2MM)	1	1	1	1	UR
	61N-45587-40	SHIM (T:1.3MM) LAINA (T:1.3MM)	1	1	1	1	UR
	61N-45587-50	SHIM (T:1.4MM) LAINA (T:1.4MM)	1	1	1	1	UR
	61N-45587-60	SHIM (T:1.5MM) LAINA (T:1.5MM)	1	1	1	1	UR
	61N-45587-70	SHIM (T:1.6MM) LAINA (T:1.6MM)	1	1	1	1	UR
5	61N-45536-00	SLEEVE, DRIVE SHAFT CAMISA EJE DE MANDO	1	1	1	1	
6	93315-220V7	BEARING COJINETE DE RODILLOS	1	1	1	1	
7	61N-44362-00	TUBE, WATER TUBO DE AGUA	1		1	1	S(16.7"),X(25.0") S(16.7"),X(25.0")
	61N-44362-10	TUBE, WATER TUBO DE AGUA	1	1	1		L(21.6") L(21.6")
8	93210-22164	O-RING ANILLO O	1		1	1	S(16.7"),X(25.0") S(16.7"),X(25.0")
9	93210-26130	O-RING ANILLO O	1		1	1	S(16.7"),X(25.0") S(16.7"),X(25.0")
	93210-26130	O-RING ANILLO O	2	2	2		L(21.6") L(21.6")
10	69P-44311-00	HOUSING, WATER PUMP CAJA BOMBA DE AGUA	1	1	1	1	
11	6L2-44367-00	DAMPER, WATER SEAL GOMA DEL SELLO DE AGUA	1	1	1	1	
12	69P-44322-00	INSERT, CARTRIDGE CARTUCHO	1	1	1	1	FOR STD FOR STD
	69P-44322-40	INSERT, CARTRIDGE CARTUCHO	1	1	1	1	FOR CHROMATE FOR CHROMATE
13	6H4-44352-02	IMPELLER IMPULSOR	1	1	1	1	
14	93210-45161	O-RING ANILLO O	1	1	1	1	
15	61N-44323-00	OUTER PLATE, CARTRIDGE PLACA EXTERIOR DEL CARTUCHO	1	1	1		FOR STD FOR STD

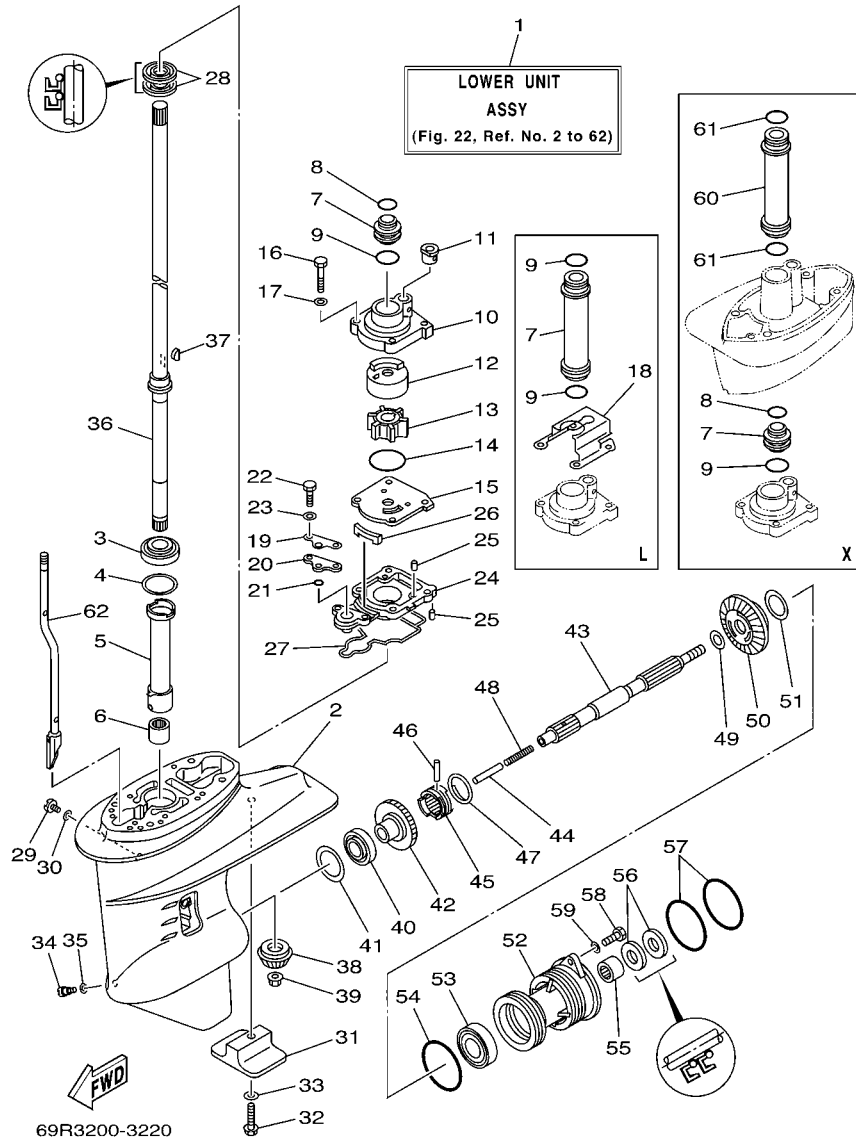

FIG. 22 LOWER CASING & DRIVE 1 IMPULSOR E INFERIOR 1

REF. NO.	PART NO. CODIGO Nº	DESCRIPTION DESCRIPCION	MH	WH	W	WC	REMARKS OBSERVACIONES
15	61N-44323-40	OUTER PLATE, CARTRIDGE PLACA EXTERIOR DEL CARTUCHO	1	1	1	1	FOR CHROMATE FOR CHROMATE
16	97095-06040	BOLT PERNO	4	4	4	4	
17	92995-06600	WASHER ARANDELA	4	4	4	4	
18	65W-44328-11	PLATE PLACA	1	1	1	1	L(21.6") L(21.6")
19	61N-44176-00	BRACKET SOPORTE	1	1	1	1	
20	61N-45321-00	PLATE PLACA	1	1	1	1	
21	93210-06ME6	O-RING ANILLO O	1	1	1	1	
22	97095-06025	BOLT PERNO	2	2	2	2	
23	92995-06600	WASHER ARANDELA	2	2	2	2	
24	61N-45331-00-5B	HOUSING, BEARING CAJA DE COJINETE	1	1	1	1	
25	93604-10M03	PIN, DOWEL PASADOR DE CLAVIJA	3	3	3	3	
26	61N-45127-00	SEAL SELLO DE GOMA	1	1	1	1	
27	61N-45315-00	PACKING, LOWER CASING EMPAQUE	1	1	1	1	
28	93101-22067	OIL SEAL SELLO ACEITE	2	2	2	2	
29	90340-08002	PLUG, STRAIGHT SCREW TORNILLO, DE DRENAJE	1	1	1	1	
30	90430-08020	GASKET JUNTA	1	1	1	1	
31	61N-45251-01	ANODE CATODE	1	1	1	1	
32	95895-06035	BOLT, FLANGE TORNILLO DE REBORDE	1	1	1	1	
33	92990-06300	WASHER, INTERNAL TOOTH ARANDELA PLANA	1	1	1	1	
34	688-45341-10	PLUG, DRAIN TAPON, DREN	1	1	1	1	
35	90430-08020	GASKET JUNTA	1	1	1	1	
36	61N-45510-00	DRIVE SHAFT ASSY EJE DE MANDO COMPL.	1	1	1	1	S(16.7") S(16.7")
	61N-45510-10	DRIVE SHAFT ASSY EJE DE MANDO COMPL.	1	1	1	1	L(21.6") L(21.6")
	61N-45510-30	DRIVE SHAFT ASSY EJE DE MANDO COMPL.	1	1	1	1	X(25.0") X(25.0")
37	90280-03M03	KEY, WOODRUFF CUNA WOODRUFF	1	1	1	1	
38	61N-45551-00	PINION (13T) PINON (13T)	1	1	1	1	
39	90179-10M14	NUT TUERCA	1	1	1	1	

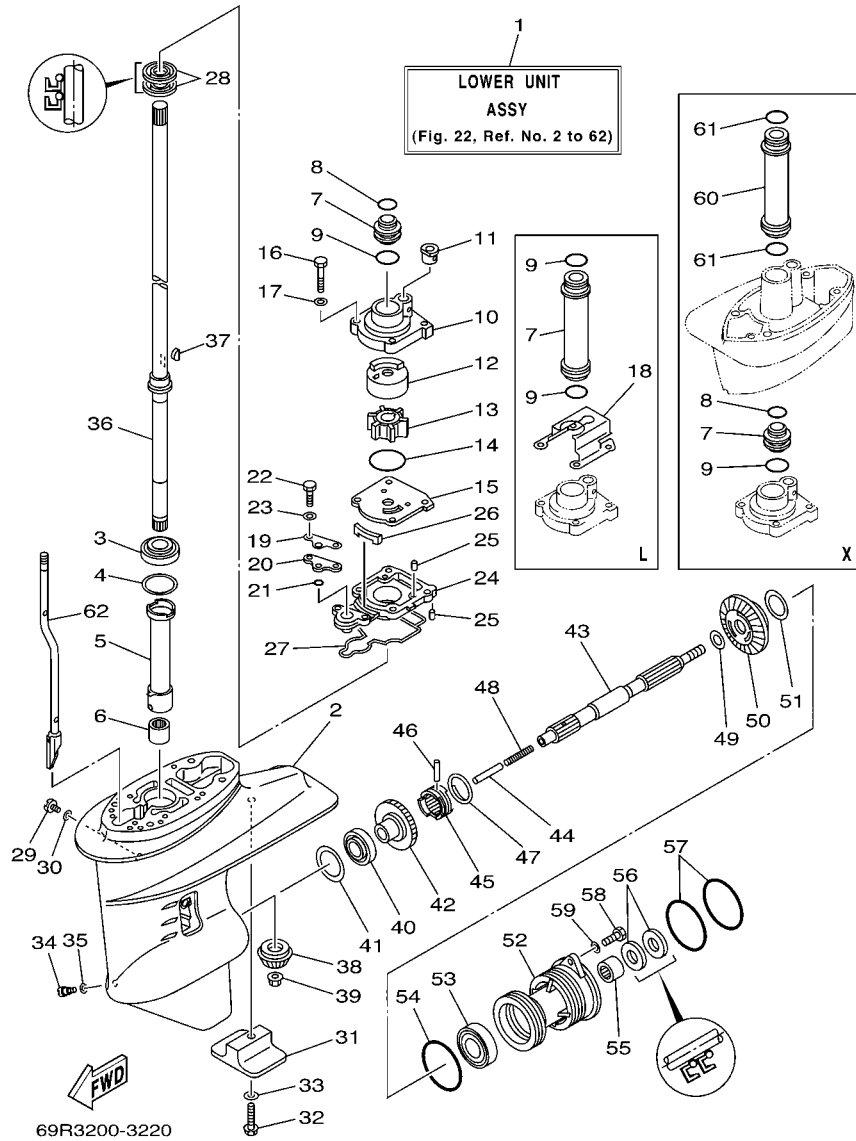

FIG. 22 LOWER CASING & DRIVE 1 IMPULSOR E INFERIOR 1

REF. NO.	PART NO. CODIGO N°	DESCRIPTION DESCRIPCION	MH	WH	W	WC	REMARKS OBSERVACIONES
40	93332-00005	BEARING COJINETE	1	1	1	1	
41	6L2-45567-00	SHIM (T:1.0MM) LAINA(T:1.0MM)	1	1	1	1	UR
	6L2-45567-10	SHIM (T:1.1MM) LAINA(T:1.1MM)	1	1	1	1	UR
	6L2-45567-20	SHIM (T:1.2MM) LAINA(T:1.2MM)	1	1	1	1	UR
	6L2-45567-30	SHIM (T:1.3MM) LAINA(T:1.3MM)	1	1	1	1	UR
	6L2-45567-40	SHIM (T:1.4MM) LAINA(T:1.4MM)	1	1	1	1	UR
42	61N-45560-10	GEAR 1 (27T) ENGRANAJE 1 (27T)	1	1	1	1	
43	65W-45611-00	SHAFT, PROPELLER EJE PROPUSOR	1	1	1	1	
44	648-45635-00	PLUNGER, SHIFT EMBOLO DE CAMBIO	1	1	1	1	
45	664-45631-02	CLUTCH, DOG EMBRAGUE DE GARRA	1	1	1	1	
46	90250-05010	PIN, STRAIGHT PASADOR CILINDRICO	1	1	1	1	
47	648-45633-00	RING, CROSS PIN ANILLO DE PASADOR	1	1	1	1	
48	90501-10065	SPRING, COMPRESSION RESORTE DE COMPRESION	1	1	1	1	
49	90201-20417	WASHER, PLATE ARANDELA PLANA	1	1	1	1	
50	61N-45571-00	GEAR 2 (27T) ENGRANAJE 2 (27T)	1	1	1	1	
51	6L2-45577-00	SHIM (T:1.0MM) LAINA(T:1.0MM)	1	1	1	1	UR
	6L2-45577-10	SHIM (T:1.1MM) LAINA(T:1.1MM)	1	1	1	1	UR
	6L2-45577-20	SHIM (T:1.2MM) LAINA(T:1.2MM)	1	1	1	1	UR
	6L2-45577-30	SHIM (T:1.3MM) LAINA(T:1.3MM)	1	1	1	1	UR
52	61N-45361-01-4D	CAP, LOWER CASING FUNDA INFERIOR	1	1	1	1	
53	93306-00612	BEARING COJINETE	1	1	1	1	
54	93210-64ME7	O-RING ANILLO O	1	1	1	1	
55	93315-22004	BEARING COJINETE DE RODILLOS	1	1	1	1	
56	93101-20M07	OIL SEAL SELLO ACEITE	2	2	2	2	
57	93210-65M50	O-RING ANILLO O	2	2	2	2	
58	97075-06020	BOLT PERNO	2	2	2	2	
59	92995-06600	WASHER ARANDELA	2	2	2	2	

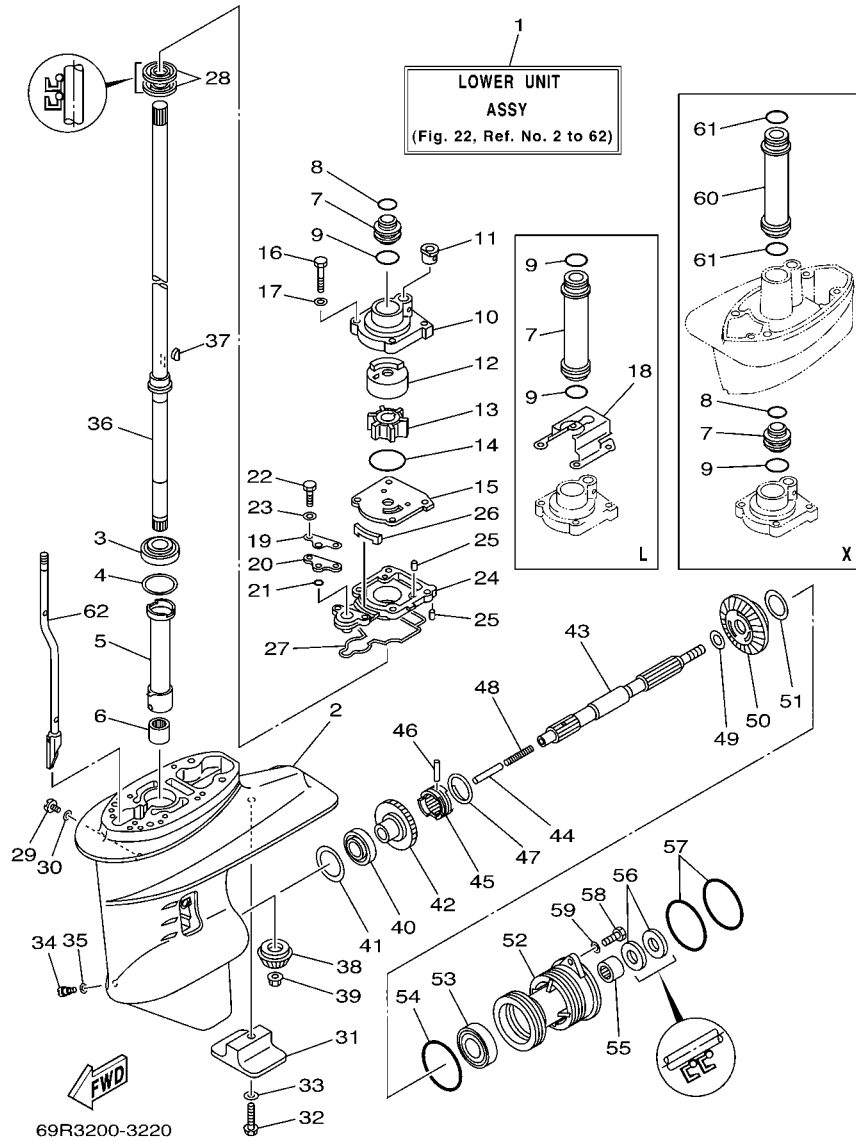
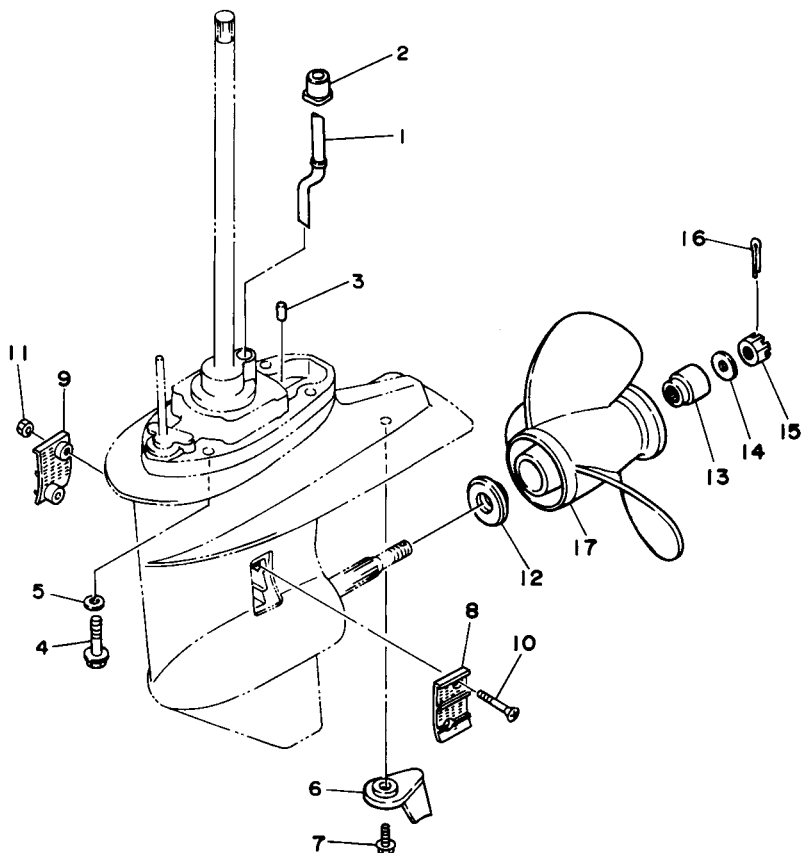

FIG. 22 LOWER CASING & DRIVE 1 IMPULSOR E INFERIOR 1

REF. NO.	PART NO. CODIGO Nº	DESCRIPTION DESCRIPCION	MH	WH	W	WC	REMARKS OBSERVACIONES
60	61N-44362-10	TUBE, WATER TUBO DE AGUA	1				X(25.0") X(25.0")
61	93210-26130	O-RING ANILLO O	2				X(25.0") X(25.0")
62	61N-44150-00	SHIFT CAM ASSY CONJUNTO EJE LEVA COMPL.	1		1	1	S(16.7") S(16.7")
	61N-44150-10	SHIFT CAM ASSY CONJUNTO EJE LEVA COMPL.	1		1	1	L(21.6") L(21.6")
	61N-44150-30	SHIFT CAM ASSY CONJUNTO EJE LEVA COMPL.	1				X(25.0") X(25.0")
<hr/>							
<hr/>							
<hr/>							
<hr/>							
<hr/>							
<hr/>							
<hr/>							
<hr/>							
<hr/>							
<hr/>							

FIG. 23 LOWER CASING & DRIVE 2

IMPULSOR E INFERIOR 2



61R0010-4180

REF. NO.	PART NO. CODIGO Nº	DESCRIPTION DESCRIPCION	MH	WH	W	WC	REMARKS OBSERVACIONES
1	61N-44361-00	TUBE, WATER TUBO DE AGUA	1		1	1	S(16.7") S(16.7")
	61N-44361-10	TUBE, WATER TUBO DE AGUA	1	1	1		L(21.6") L(21.6")
	61N-44361-30	TUBE, WATER TUBO DE AGUA	1				X(25.0") X(25.0")
2	689-44366-00	DAMPER, WATER SEAL GOMA DEL SELLO DE AGUA	1	1	1	1	
3	93606-11M24	PIN, DOWEL PASADOR DE CLAVIJA	2	2	2	2	
4	90105-10M12	BOLT, FLANGE TORNILLO	4	4	4	4	S(16.7"),L(21.6") S(16.7"),L(21.6")
5	92995-10600	WASHER ARANDELA	4	4	4	4	S(16.7"),L(21.6") S(16.7"),L(21.6")
6	61N-45371-00	TAB-TRIM QUILLA ESTABILIZADOR	1	1	1	1	
7	90119-06M48	BOLT, WITH WASHER TORNILLO CON ARANDELA	1	1	1	1	
8	6L2-45214-00	COVER, WATER INLET 1 CUBIERTA ENTRADA AGUA 1	1	1	1	1	
9	6L2-45215-00	COVER, WATER INLET 2 CUBIERTA ENTRADA AGUA 2	1	1	1	1	
10	90151-05M05	SCREW, COUNTERSUNK TORNILLO EMBUTIDO	2	2	2	2	
11	90185-05002	NUT, SELF-LOCKING TUERCA AUTOBLOCANTE	2	2	2	2	
12	6L2-45987-01	SPACER ESPACIADOR	1	1	1	1	
13	689-45997-00	SPACER ESPACIADOR	1	1	1	1	
14	92990-14200	WASHER, PLAIN ARANDELA PLANA	1	1	1	1	
15	90171-14013	NUT, CASTLE TUERCA ENTALLADA	1	1	1	1	
16	91490-30022	PIN, COTTER CHAVETA	1	1	1	1	
17	664-45941-01-EL	PROPELLER (3X9-7/8X9-F) PROPELA (3X9-7/8X9-F)	1	1	1	1	UR UR
	664-45943-01-EL	PROPELLER (3X9-7/8X8-F) PROPELA (3X9-7/8X8-F)	1	1	1	1	UR UR
	664-45945-00-EL	PROPELLER (3X9-7/8X10-1/2-F) PROPELA (3X9-7/8X10-1/2-F)	1	1	1	1	UR UR
	664-45947-01-EL	PROPELLER (3X9-7/8X11-1/4-F) PROPELA (3X9-7/8X11-1/4-F)	1	1	1	1	UR UR
	664-45949-02-EL	PROPELLER (3X9-7/8X13-F) PROPELA (3X9-7/8X13-F)	1	1	1	1	UR UR
	664-45952-00-EL	PROPELLER (3X9-7/8X14-F) PROPELA (3X9-7/8X14-F)	1	1	1	1	UR UR
	664-45954-01-EL	PROPELLER (3X9-7/8X12-F) PROPELA (3X9-7/8X12-F)	1	1	1	1	UR UR
	62C-45941-00-EL	PROPELLER (3X9-7/8X10-F) PROPELA (3X9-7/8X10-F)	1	1	1	1	UR UR

FIG. 26 REMOTE CONTROL BOX

CONTROL REMOTO COMPLETO

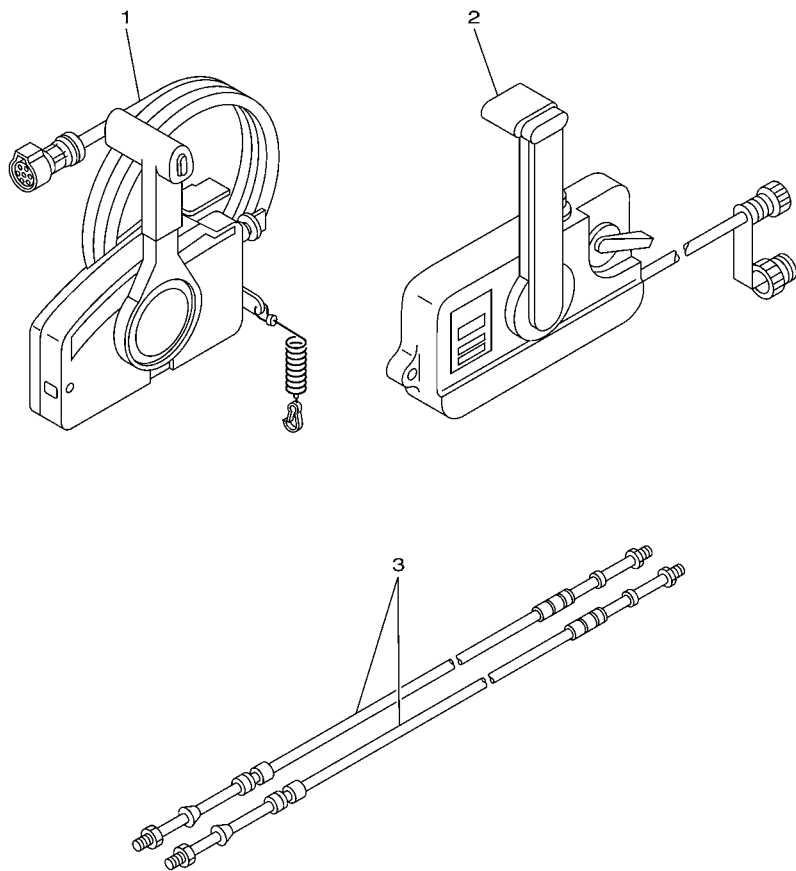

REF. NO.	PART NO. CODIGO Nº	DESCRIPTION DESCRIPCION	MH	WH	W	WC	REMARKS OBSERVACIONES
1	703-48230-15	REMOTE CONTROL ASSY (7P) CONTROL REMOTO COMPL. (7P)			1		AP WITHOUT PT/T SW. AP WITHOUT PT/T SW.
2	701-48102-51	REMOTE CONTROL ASSY REMOTO CONTROL COMPL				1	AP AP
3	701-48320-20	CABLE, REMOTE CONTROL L=13F CABLE CONTROL REMOTO L=13F			2	2	UR UR
	701-48320-50	CABLE, REMOTE CONTROL L=15F CABLE CONTROL REMOTO L=15F			2	2	UR UR

 69R3200-3260

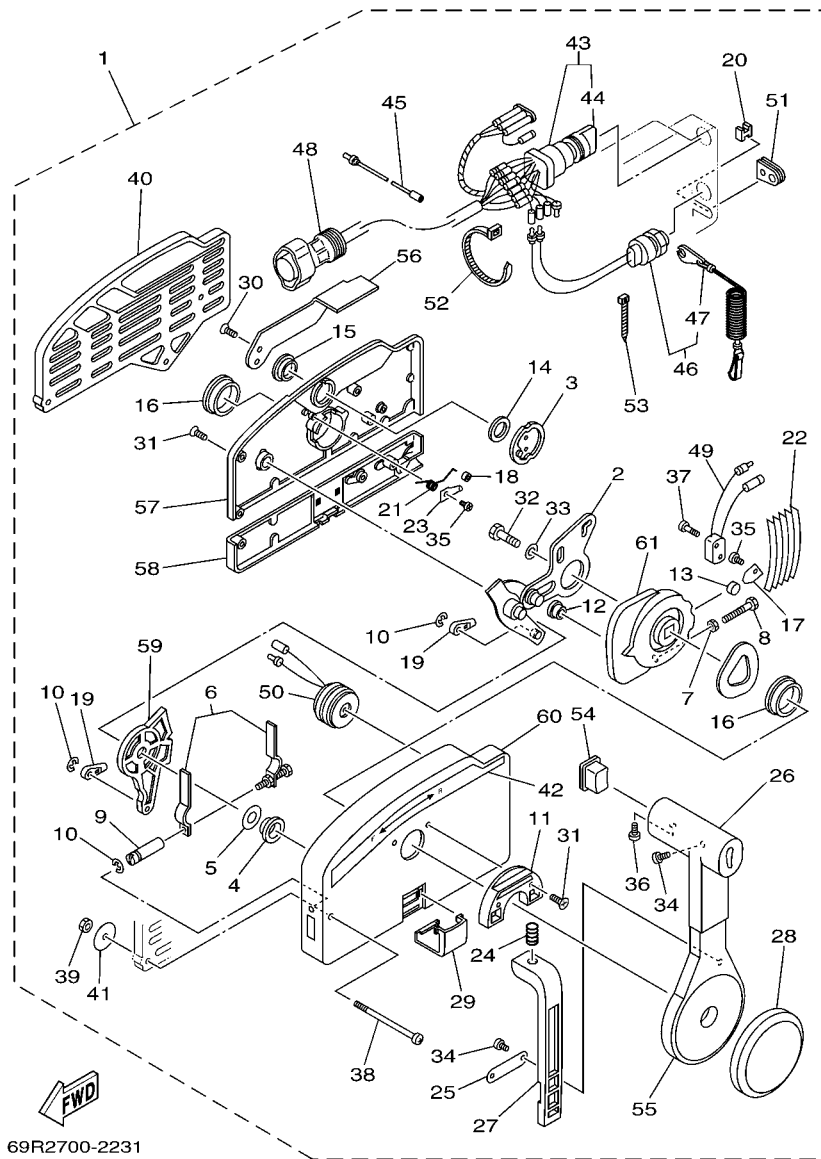

69R2700-2231

FIG. 27 REMOTE CONTROL ASSY 1 CONTROL REMOTO COMPL 1

REF. NO.	PART NO. CODIGO N°	DESCRIPTION DESCRIPCION	MH	WH	W	WC	REMARKS OBSERVACIONES
1	703-48230-15	REMOTE CONTROL ASSY (7P) CONTROL REMOTO COMPL. (7P)			1		AP WITHOUT PT/T SW. AP WITHOUT PT/T SW.
2	703-48261-11	.ARM, THROTTLE .BRAZO ACELERADOR			1		
3	703-48153-00	.SHAFT, FREE ACCEL. .EJE			1		
4	703-48235-00	.BUSHING .BUJE			1		
5	703-48268-00	.SPACER .ESPACIADOR 3			1		
6	703-48264-00	.FRICTION, THROTTLE .FRICCION DE ACELERADOR			1		
7	95380-05600	.NUT .TUERCA			1		
8	97380-05025	.BOLT .TORNILLO HEXAGONAL			1		
9	703-48265-00	.SHAFT, FRICTION .EJE FRICCION			1		
10	93430-06024	.CIRCLIP .SEGURO			3		
11	703-48245-00	.PLATE, LOCK .PLACA CERRADURA			1		
12	703-48252-00	.ROLLER, CAM .RODILLO LEVA			1		
13	701-48248-00	.ROLLER, FREE ACCEL. .RODILLO ACELERADOR LIBRE			1		
14	703-48198-00	.WASHER, WAVE .RONDANA ONDULADA 3			1		
15	703-48243-00	.BUSHING .BUJE 3			1		
16	703-48236-00	.BUSHING 1 .BUJE			2		
17	703-48189-00	.RETAINER .RETENEDOR			1		
18	703-48234-00	.ROLLER, DETENT .RODILLO			1		
19	703-48345-01	.CABLE END, REMOTE CONTROL 2 .TERMINAL CABLE DE CONTROL REM			2		
20	703-48358-00	.ANCHOR, CABLE .ABRAZADERA CABLE			1		
21	703-48244-00	.SPRING, FREE ACCEL. .RESORTE ACELERADOR LIBRE			1		
22	703-48238-00	.SPRING, DETENT .RESORTE			5		
23	703-48246-00	.SPACER .ESPACIADOR			1		
24	703-48227-00	.SPRING, NEUTRAL LOCK .RESORTE DE SEGURO			1		
25	703-48226-00	.PLATE, STOPPER .PLACA RETEN			1		
26	703-48222-00	.GRIP, CONTROL LEVER .MANGO DE PALANCA CONTROL			1		SINGLE SINGLE
27	703-48223-00	.LOCK, NEUTRAL .CERRADURA NEUTRO			1		

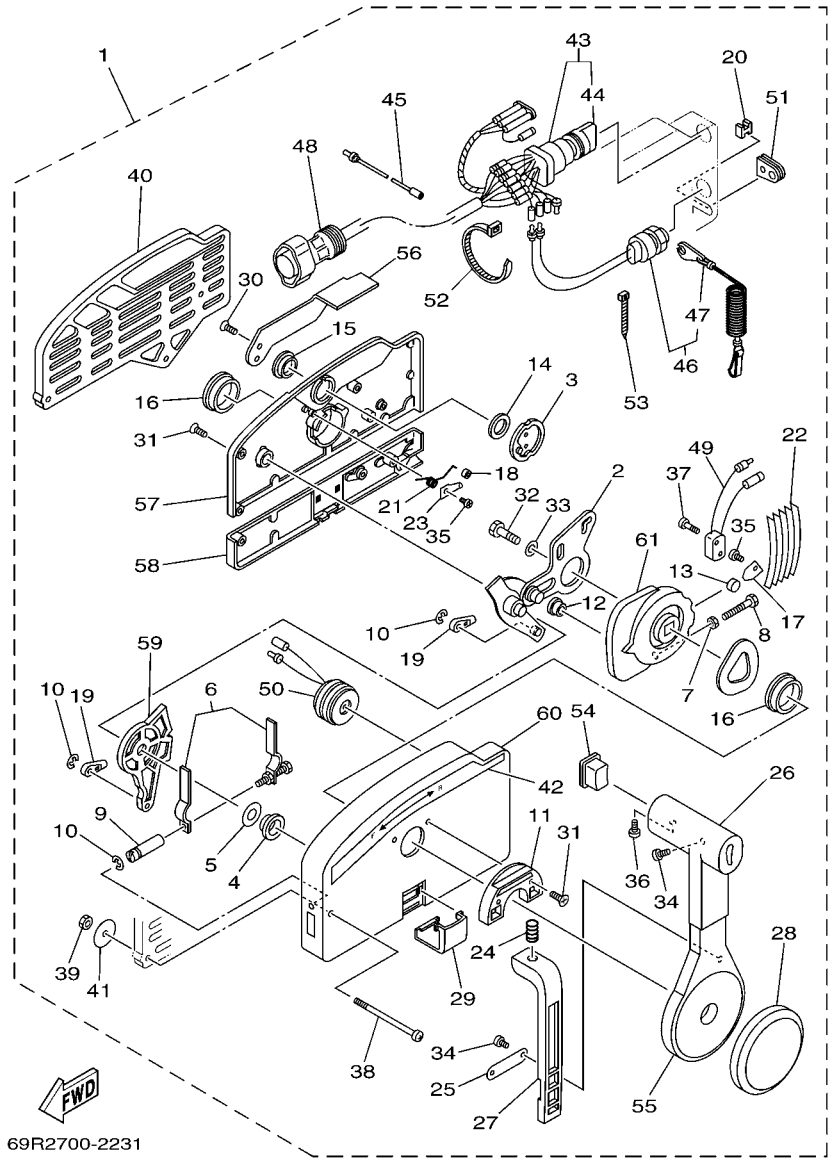

69R2700-2231

FIG. 27 REMOTE CONTROL ASSY 1 CONTROL REMOTO COMPL 1

REF. NO.	PART NO. CODIGO Nº	DESCRIPTION DESCRIPCION	MH	WH	W	WC	REMARKS OBSERVACIONES
28	703-48225-00	.COVER .CUBIERTA			1		
29	703-48219-00	.COVER, LEAD .CUBIERTA			1		
30	703-48281-00	.SCREW .TORNILLO 1			2		
31	703-48282-00	.SCREW .TORNILLO 2			7		
32	97380-08030	.BOLT .TORNILLO HEXAGONAL			1		
33	92990-08600	.WASHER, PLATE .ARANDELA PLANA			1		
34	98580-04010	.SCREW, PAN HEAD .TORNILLO DE CABEZA CRUZADA			3		
35	98580-04006	.SCREW, PAN HEAD .TORNILLO DE CABEZA CRUZADA			2		
36	98580-05010	.SCREW, PAN HEAD .TORNILLO DE CABEZA CRUZADA			1		
37	98580-03015	.SCREW, PAN HEAD .TORNILLO DE CABEZA CRUZADA			2		
38	703-48291-10	.SCREW (M6) .TORNILLO (M6)			3		
39	95380-06600	.NUT, HEXAGON .TUERCA			3		
40	703-48293-10	.SPACER, REMOTE CONTROL .ESPACIADOR			1		SINGLE SINGLE
41	701-48287-00	.WASHER .ARANDELA			3		
42	703-48215-00	.GRAPHIC .CALCOMANIA 1			1		
43	703-82510-33	.MAIN SWITCH ASSY .CONJUNTO DE LLAVE IGNICION			1		
44	703-82577-00	..CAP, KEY ..TAPA			1		
45	703-82531-00	.WIRE, LEAD .CABLE CONDUCTOR			1		
46	688-82575-01	.ENGINE STOP SWITCH ASSY .INTERRUPTOR DE PARADA COMPL			1		
47	682-82556-00	..LANYARD, STOP SWITCH ..RETENER			1		
48	688-82586-21	.EXTENSION, WIRE HARNESS .EXTENSION, CONJ. DE CABLES			1		L:5M (7P) L:5M (7P)
49	703-82540-00	.NEUTRAL SWITCH ASSY .INTERRUPTOR NEUTRAL COMPL			1		
50	703-83383-02	.BUZZER .ZUMBADOR			1		
51	703-48284-00	.GROMMET .TAPON 1			1		
52	703-82591-00	.BAND .BANDA			1		
53	703-82592-00	.BAND .BANDA			1		
54	703-48224-00	.COVER, CONTROL LEVER .CUBIERTA DE PALANCA CONTROL			1		WITHOUT PT/T SW. WITHOUT PT/T SW.

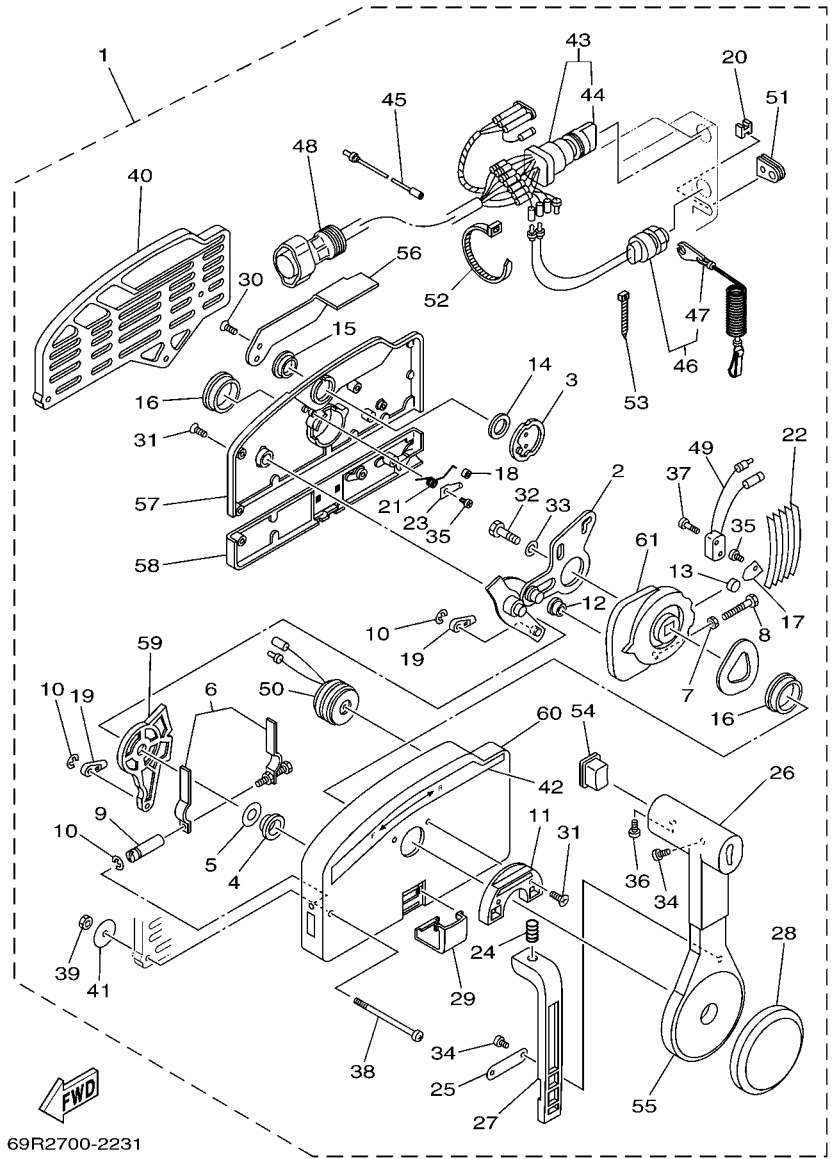

69R2700-2231

FIG. 27 REMOTE CONTROL ASSY 1 CONTROL REMOTO COMPL 1

REF. NO.	PART NO. CODIGO Nº	DESCRIPTION DESCRIPCION	MH	WH	W	WC	REMARKS OBSERVACIONES
55	703-48221-00	.LEVER, CONTROL .PALANCA CONTROL				1	
56	703-48152-00	.KNOB, FREE ACCEL. .PERILLA				1	
57	703-48212-00	.BACK PLATE 1 .PLACA TRASERA 1				1	
58	703-48213-00	.BACK PLATE 2 .PLACA TRASERA 2				1	
59	703-48271-00	.ARM, SHIFT .BRAZO CAMBIADOR				1	
60	703-48211-01	.HOUSING,1 .CAJA				1	
61	703-48232-00	.GEAR .ENGRANAJE 1				1	

FIG. 28 REMOTE CONTROL ASSY 2 CONTROL REMOTO COMPL 2

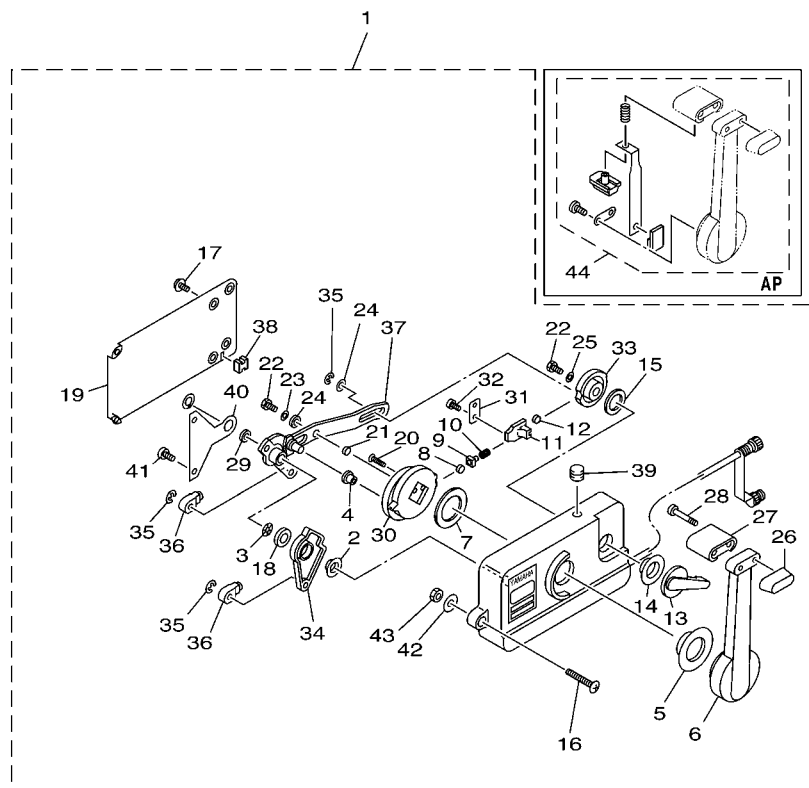

69R3200-3280

REF. NO.	PART NO. CODIGO Nº	DESCRIPTION DESCRIPCION	MH	WH	W	WC	REMARKS OBSERVACIONES
1	701-48102-51	REMOTE CONTROL ASSY REMOTO CONTROL COMPL				1	AP AP
2	701-48235-00	.BUSHING .BUJE				1	
3	701-48197-10	.WASHER, WAVE .RONDANA ONDULADA 2				1	
4	701-48252-00	.ROLLER, CAM .RODILLO LEVA				1	
5	701-48234-00	.BUSHING 1 .BUJE				1	
6	701-48221-00	.LEVER, CONTROL .PALANCA CONTROL				1	
7	701-48196-11	.WASHER, WAVE .ARANDELA ONDULADA				1	
8	701-48236-00	.ROLLER, DETENT .RODILLO				1	
9	702-48237-00	.ADAPTOR .ADAPTADOR				1	
10	702-48238-00	.SPRING, DETENT .RESORTE				1	
11	701-48249-00	.ADAPTOR, SPRING .RESORTE ADAPTADOR				1	
12	701-48248-00	.ROLLER, FREE ACCEL. .RODILLO ACELERADOR LIBRE				1	
13	701-48152-20	.KNOB, FREE ACCEL. .PERILLA				1	LEFT LEFT
14	701-48243-00	.BUSHING .BUJE 3				1	
15	701-48198-10	.WASHER, WAVE .RONDANA ONDULADA 3				1	
16	701-48281-10	.SCREW .TORNILLO 1				3	
17	701-48289-00	.SCREW .TORNILLO 4				4	
18	701-48268-00	.SPACER .ESPACIADOR 3				1	
19	701-48213-00	.BACK PLATE 2 .PLACA TRASERA 2				1	
20	92780-06025	.SCREW, FLAT HEAD .TORNILLO CABEZA PLANA				2	
21	701-48255-00	.COLLAR .COLLAR 1				1	
22	97390-06018	.BOLT .TORNILLO				2	
23	702-48288-00	.WASHER, PLAIN .ARANDELA				1	
24	701-48246-00	.SPACER .ESPACIADOR				2	
25	92990-06300	.WASHER, INTERNAL TOOTH .ARANDELA PLANA				1	
26	701-48229-00	.GRIP, CONTROL LEVER .MANGO DE PALANCA CONTROL 2				1	
27	701-48222-00	.GRIP, CONTROL LEVER .MANGO DE PALANCA CONTROL				1	

B3

FIG. 28 REMOTE CONTROL ASSY 2 CONTROL REMOTO COMPL 2

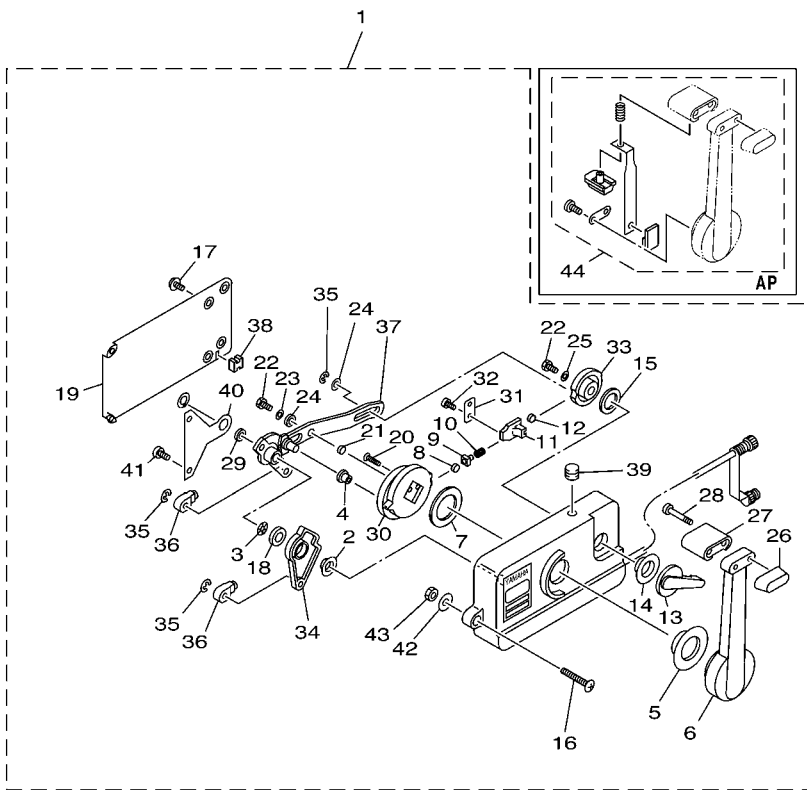

REF. NO.	PART NO. CODIGO Nº	DESCRIPTION DESCRIPCION	MH	WH	W	WC	REMARKS OBSERVACIONES
28	701-48282-00	.SCREW .TORNILLO 2				2	
29	701-48266-00	.SPACER .ESPACIADOR 2				1	
30	701-48232-00	.GEAR .ENGRANAJE 1				1	
31	701-48189-11	.RETAINER .RETENEDOR				1	
32	98580-05010	.SCREW, PAN HEAD .TORNILLO DE CABEZA CRUZADA				2	
33	701-48153-12	.SHAFT, FREE ACCEL. .EJE				1	
34	701-48271-10	.ARM, SHIFT .BRAZO CAMBIADOR				1	LEFT LEFT
35	93430-06024	.CIRCLIP .SEGURO				3	
36	703-48345-01	.CABLE END, REMOTE CONTROL 2 .TERMINAL CABLE DE CONTROL REM				2	
37	701-48261-10	.ARM, THROTTLE .BRAZO ACELERADOR				1	LEFT LEFT
38	701-48358-00	.ANCHOR, CABLE .ABRAZADERA CABLE				1	
39	701-48138-50	.CAP, LOCK ARM .TAPON				1	
40	701-48133-00	.PLATE, LINK .PLACA DE ESLABON				1	
41	98580-05020	.SCREW, PAN HEAD .TORNILLO DE CABEZA CRUZADA				2	
42	701-48287-00	.WASHER .ARANDELA				3	
43	95380-06600	.NUT, HEXAGON .TUERCA				3	
44	701-48280-00	NEUTRAL LOCK KIT TORNILLO				1	AP AP



69R3200-3280

FIG. 29 SWITCH & PANEL

PANEL DE INTERRUPTOR

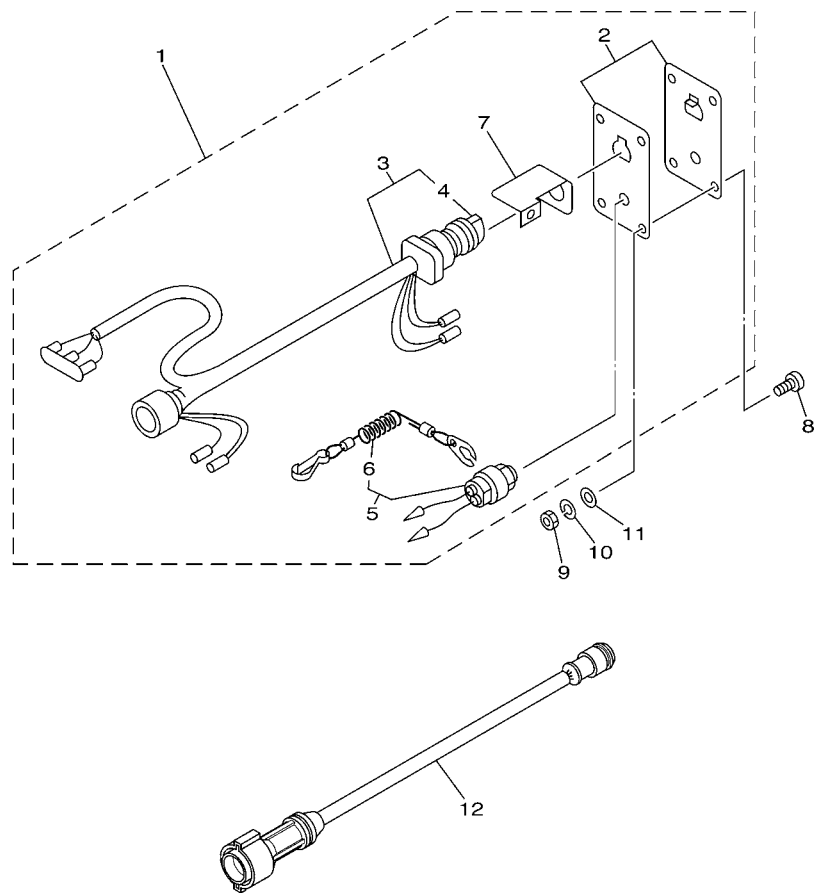

69R3200-3290

REF. NO.	PART NO. CODIGO Nº	DESCRIPTION DESCRIPCION	MH	WH	W	WC	REMARKS OBSERVACIONES
1	689-82570-1B	PANEL SWITCH ASSY INTERRUPTOR DE PANEL COMPL.				1	AP AP
2	704-82571-02	.PANEL, SWITCH .PANEL DE INTERRUPTOR				1	
3	689-82510-04	.MAIN SWITCH ASSY .CONJUNTO DE LLAVE IGNICION				1	
4	703-82577-00	..CAP, KEY ..TAPA				1	
5	688-82575-01	.ENGINE STOP SWITCH ASSY .INTERRUPTOR DE PARADA COMPL				1	
6	682-82556-00	..LANYARD, STOP SWITCH ..RETENER				1	
7	64D-82581-00	.STAY, CORD CLAMP .SOPORTE DE GRAMPA DE CABLE				1	
8	90149-05M05	SCREW TORNILLO DE REGLAJE				4	AP AP
9	95380-05600	NUT TUERCA				4	AP AP
10	92990-05100	WASHER, SPRING ARANDELA PLANA				4	AP AP
11	92990-05600	WASHER, PLATE ARANDELA PLANA				4	AP AP
12	688-82586-50	EXTENSION, WIRE HARNESS (5M) EXTENSION, CONJ. DE CABLES (5M)				1	AP (7P) AP (7P)

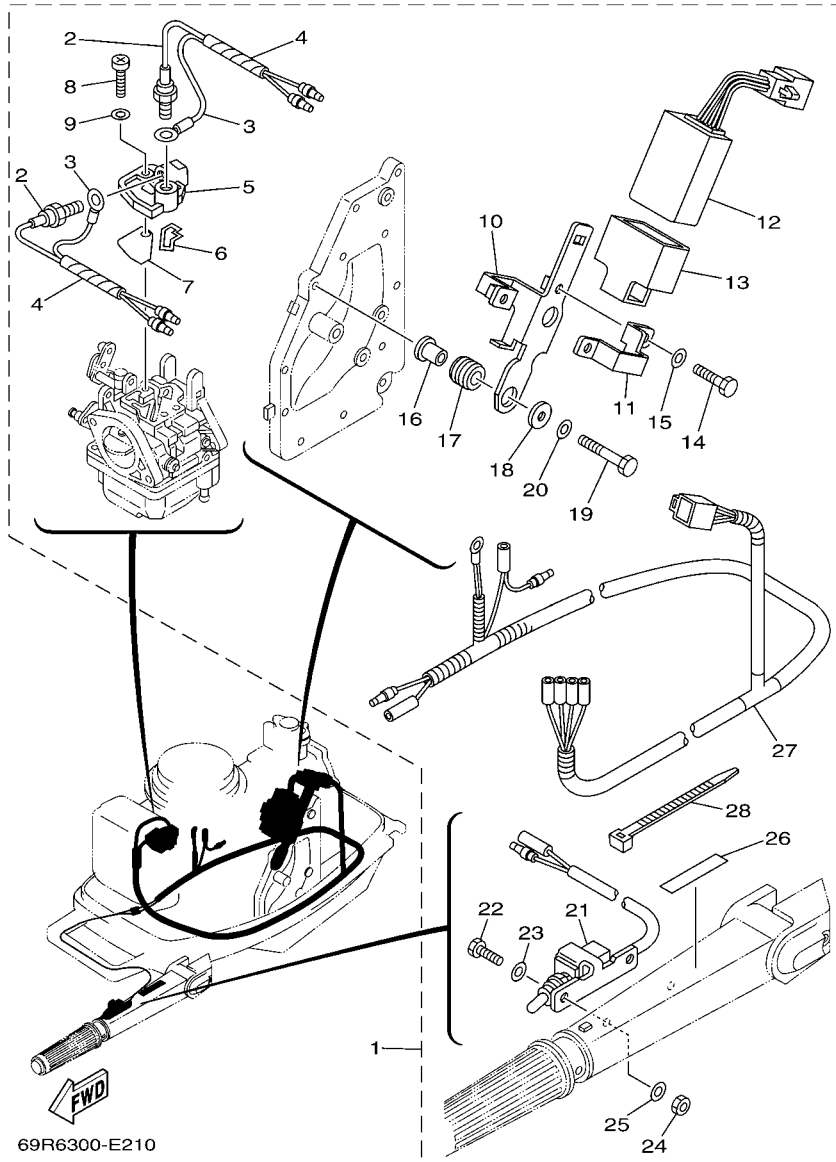

69R6300-E210

FIG. 30 OPTIONAL PARTS

PARTES OPCIONALES

REF. NO.	PART NO. CODIGO Nº	DESCRIPTION DESCRIPCION	MH	WH	W	WC	REMARKS OBSERVACIONES
1	69S-83790-01	HEATER ASSY .CALENTADOR	1	1	1	1	AP 25B,30H AP 25B,30H
2	69S-83793-00	.HEATER COMP. .CALENTADOR COMPLETO	2	2	2	2	
3	69W-83354-00	.WIRE, EARTH LEAD 1 .CABLE CONDUCTOR A TIERRA	2	2	2	2	
4	90446-06M90	.HOSE (L120) .TUBO (L120)	2	2	2	2	
5	69S-12466-00-94	.EXCHANGER, HEAT .CAMBIADOR DE CALOR	1	1	1	1	
6	69S-14227-00	.WASHER .EMPAQUE	1	1	1	1	
7	69S-14237-00	.GASKET .EMPAQUE	1	1	1	1	
8	97880-04012	.SCREW, PAN HEAD .TORNILLO DE CABEZA CON PLANA	2	2	2	2	
9	92990-04600	.WASHER, PLATE .ARANDELA PLANA	2	2	2	2	
10	69S-14291-00	.BRACKET 1 .SOPORTE 1	1	1	1	1	
11	69S-14292-00	.BRACKET 2 .SOPORTE 2	1	1	1	1	
12	67F-81930-00	.CONTROL UNIT ASSY .UNIDAD DE CONTROL COMPLETA	1	1	1	1	
13	69W-85546-00	.BAND .BANDA	1	1	1	1	
14	97095-06016	.BOLT .PERNO	2	2	2	2	
15	92995-06600	.WASHER .ARANDELA	2	2	2	2	
16	90387-06M64	.COLLAR .ESPACIADOR	2	2	2	2	
17	90480-10M23	.GROMMET .TAPON	2	2	2	2	
18	90201-06M62	.WASHER, PLATE .ARANDELA PLANA	2	2	2	2	
19	97095-06045	.BOLT .PERNO	2	2	2	2	
20	92995-06600	.WASHER .ARANDELA	2	2	2	2	
21	69S-8251S-00	.SWITCH COMP. .INTERRUPTOR	1	1	1	1	
22	97095-06016	.BOLT .PERNO	2	2	2	2	
23	92995-06600	.WASHER .ARANDELA	2	2	2	2	
24	95380-06600	.NUT, HEXAGON .TUERCA	2	2	2	2	
25	92990-06600	.WASHER, PLATE .ARANDELA PLANA	2	2	2	2	
26	6E0-83627-01	.LABEL, CAUTION 7 .ETIQUETA DE PRECAUCION 7	1	1	1	1	
27	69S-81971-00	.WIRE, LEAD .CABLE CONDUCTOR	1	1	1	1	

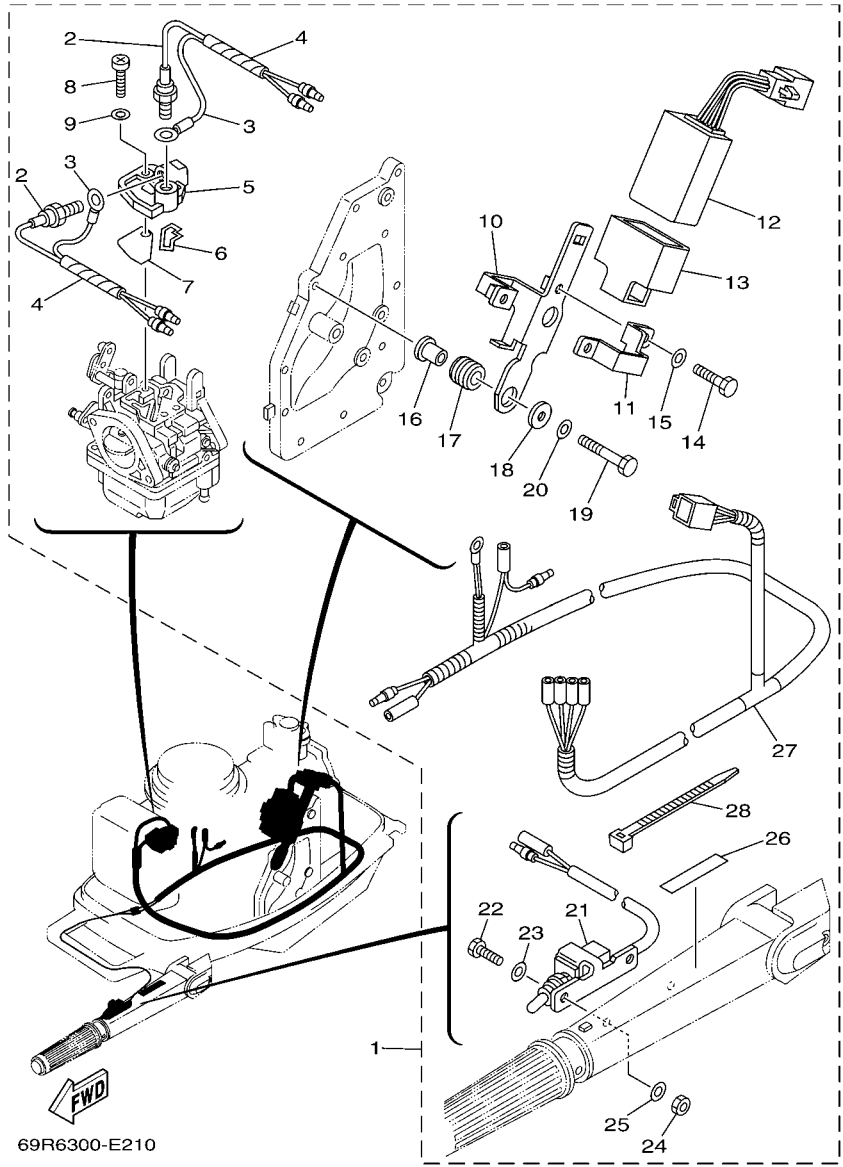

69R6300-E210

FIG. 30 OPTIONAL PARTS

PARTES OPCIONALES

REF. NO.	PART NO. CODIGO Nº	DESCRIPTION DESCRIPCION	MH	WH	W	WC	REMARKS OBSERVACIONES
28	90465-13M97	.CLAMP .BRIDA	8	8	8	8	

FIG. 31 REPAIR KIT 1

ESTUCHE REPARATION 1

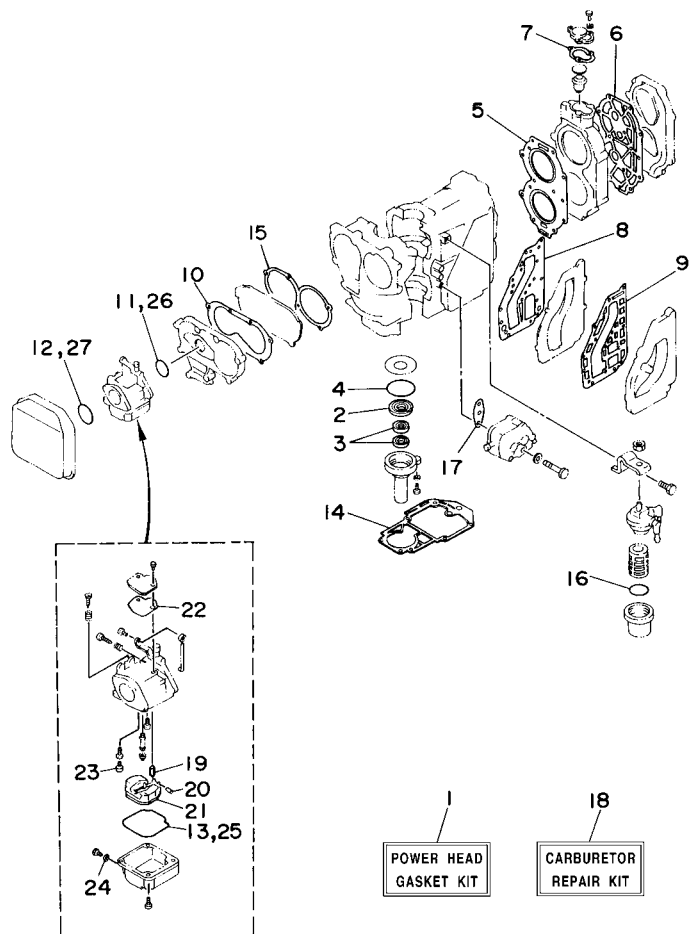

REF. NO.	PART NO. CODIGO N°	DESCRIPTION DESCRIPCION	MH	WH	W	WC	REMARKS OBSERVACIONES
1	69P-W0001-00	POWER HEAD GASKET KIT JUEGO DE EMPAQUE DE MOTOR	1	1	1	1	
2	93102-25008	.OIL SEAL .SELLO ACEITE	1	1	1	1	
3	93101-16001	.OIL SEAL .SELLO ACEITE	2	2	2	2	
4	93210-58M21	.O-RING .ANILLO O	1	1	1	1	
5	61N-11181-A1	.GASKET, CYLINDER HEAD 1 JUNTA, DE CULATA 1	1	1	1	1	
6	61T-11193-A1	.GASKET, HEAD COVER 1 .EMPAQUE	1	1	1	1	
7	655-12414-A1	.GASKET, COVER .EMPAQUE	1	1	1	1	
8	6K8-41122-A1	.GASKET, EXHAUST INNER COVER .EMPAQUE	1	1	1	1	
9	6K8-41124-A1	.GASKET, EXHAUST OUTER COVER .EMPAQUE	1	1	1	1	
10	648-13645-A0	.GASKET, MANIFOLD 1 .EMPAQUE	1	1	1	1	
11	61N-14198-00	.GASKET .EMPAQUE	1	1	1	1	
12	93210-40659	.O-RING .ANILLO O	1	1	1	1	
13	6L2-14384-00	.GASKET, FLOAT CHAMBER .EMPAQUE DE CAMARA DE BOIA	1	1	1	1	
14	689-45113-A1	.GASKET, UPPER CASING .EMPAQUE	1	1	1	1	
15	648-13621-A1	.GASKET, VALVE SEAT JUNTA, DE VALV.DE EMPAQUE	1	1	1	1	
16	93210-32738	.O-RING .ANILLO O	1	1	1	1	
17	650-24431-A0	.GASKET, FUEL PUMP 1 .EMPAQUE BOMBA COMBUST 1	1	1	1	1	
18	61N-W0093-00	CARBURETOR REPAIR KIT KIT REPARACION CARBURADOR	1	1	1	1	
19	61N-14392-00	.VALVE, NEEDLE .VALVULA DE AGUJA	1	1	1	1	
20	6E5-14386-01	.PIN, FLOAT .PASADOR DE BOIA	1	1	1	1	
21	6L2-14385-00	.FLOAT .BOIA	1	1	1	1	
22	6L2-14399-00	.GASKET .EMPAQUE	1	1	1	1	
23	50M-14355-00	.PLUG .TAPON	1	1	1	1	
24	6L2-14398-00	.GASKET .EMPAQUE	1	1	1	1	
25	6L2-14384-00	.GASKET, FLOAT CHAMBER .EMPAQUE DE CAMARA DE BOIA	1	1	1	1	
26	61N-14198-00	.GASKET .EMPAQUE	1	1	1	1	
27	93210-40659	.O-RING .ANILLO O	1	1	1	1	

FWD
61R0700-4180

FIG. 32 REPAIR KIT 2

ESTUCHE REPARATION 2

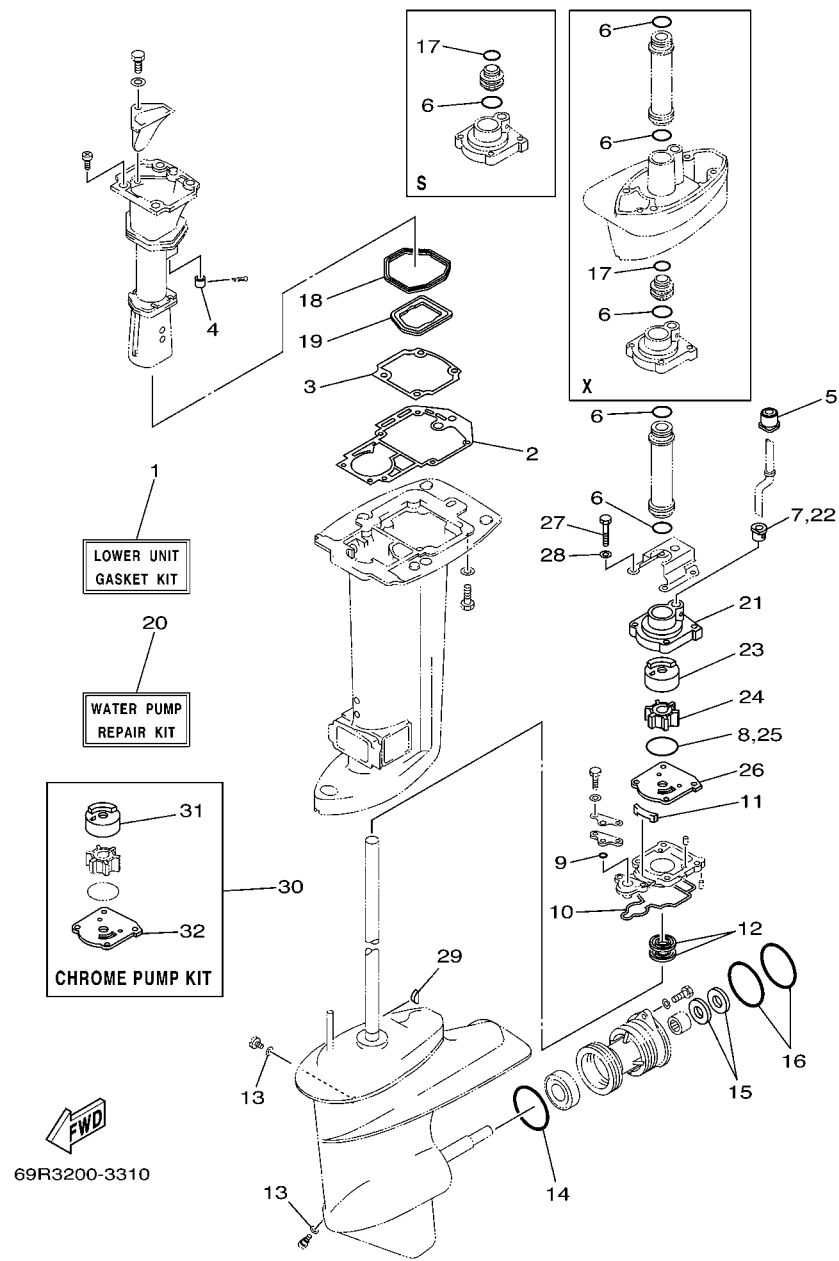

REF. NO.	PART NO. CODIGO Nº	DESCRIPTION DESCRIPCION	MH	WH	W	WC	REMARKS OBSERVACIONES
1	69P-W0001-20	LOWER UNIT GASKET KIT JUEGO DE EMPAQUE UNIDAD INFER.	1	1	1	1	
2	689-45113-A1	.GASKET, UPPER CASING .EMPAQUE	1	1	1	1	
3	69P-41134-A0	.GASKET, EXHAUST MANIFOLD .EMPAQUE	1	1	1	1	
4	6A8-41135-00	.GASKET, EXHAUST MANIFOLD .EMPAQUE	1	1	1	1	
5	689-44366-00	.DAMPER, WATER SEAL .GOMA DEL SELLO DE AGUA	1	1	1	1	
6	93210-26130	.O-RING .ANILLO O	3	3	3	3	UN UN
7	6L2-44367-00	.DAMPER, WATER SEAL .GOMA DEL SELLO DE AGUA	1	1	1	1	
8	93210-45161	.O-RING .ANILLO O	1	1	1	1	
9	93210-06ME6	.O-RING .ANILLO O	1	1	1	1	
10	61N-45315-00	.PACKING, LOWER CASING .EMPAQUE	1	1	1	1	
11	61N-45127-00	.SEAL .SELLO DE GOMA	1	1	1	1	
12	93101-22067	.OIL SEAL .SELLO ACEITE	2	2	2	2	
13	90430-08020	.GASKET .JUNTA	2	2	2	2	
14	93210-64ME7	.O-RING .ANILLO O	1	1	1	1	
15	93101-20M07	.OIL SEAL .SELLO ACEITE	2	2	2	2	
16	93210-65M50	.O-RING .ANILLO O	2	2	2	2	
17	93210-22164	.O-RING .ANILLO O	1	1	1	1	S(16.7"),X(25.0") S(16.7"),X(25.0")
18	69P-41138-00	.SEAL, EXT. 1 .SELLO, ESCAPE 1	1	1	1	1	
19	69P-41139-00	.SEAL, EXT. 2 .SELLO, ESCAPE 2	1	1	1	1	
20	69P-W0078-00	WATER PUMP REPAIR KIT ESTUCHE REPARACION BOMBA AGUA	1	1	1	1	
21	69P-44311-00	.HOUSING, WATER PUMP .CAJA BOMBA DE AGUA	1	1	1	1	
22	6L2-44367-00	.DAMPER, WATER SEAL .GOMA DEL SELLO DE AGUA	1	1	1	1	
23	69P-44322-00	.INSERT, CARTRIDGE .CARTUCHO	1	1	1	1	
24	6H4-44352-02	.IMPELLER .IMPULSOR	1	1	1	1	
25	93210-45161	.O-RING .ANILLO O	1	1	1	1	
26	61N-44323-00	.OUTER PLATE, CARTRIDGE .PLACA EXTERIOR DEL CARTUCHO	1	1	1	1	
27	97095-06040	.BOLT .PERNO	4	4	4	4	

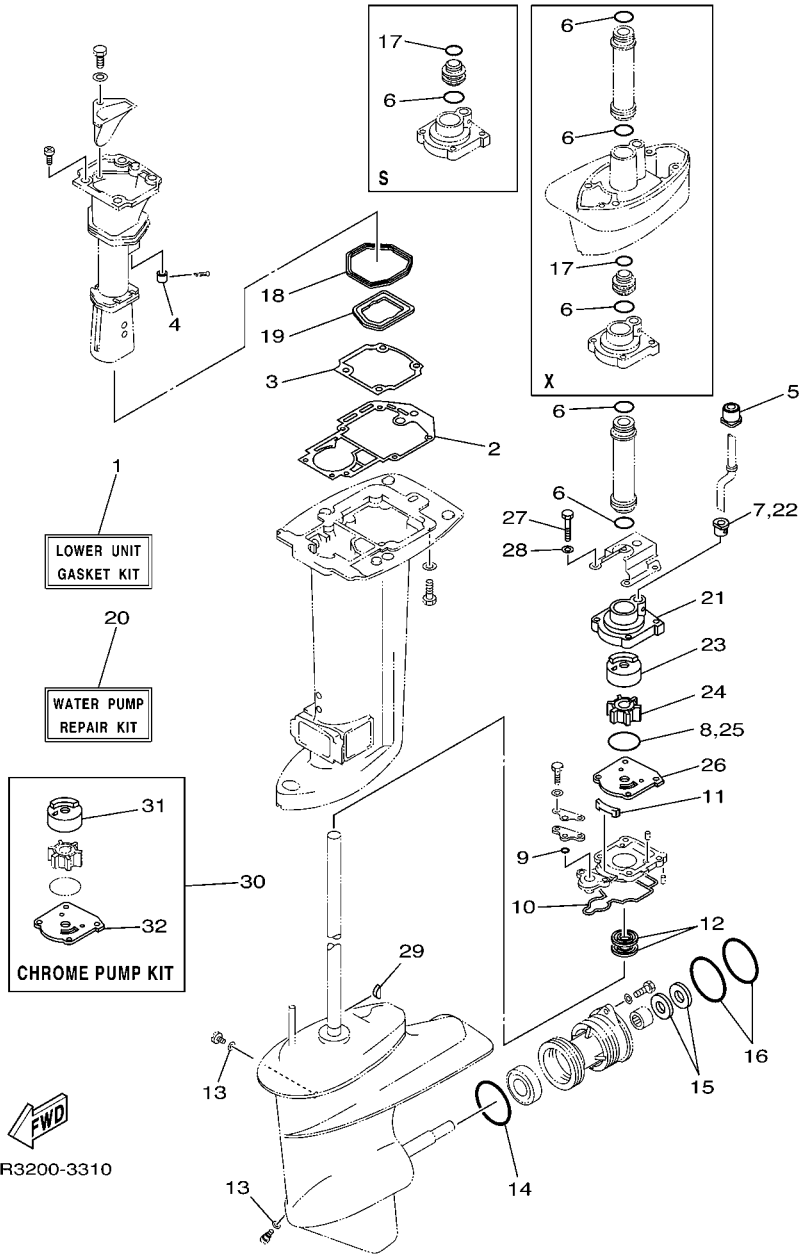

FIG. 32 REPAIR KIT 2

ESTUCHE REPARACION 2

REF. NO.	PART NO. CODIGO N°	DESCRIPTION DESCRIPCION	MH	WH	W	WC	REMARKS OBSERVACIONES
28	92995-06600	.WASHER .ARANDELA	4	4	4	4	
29	90280-03M03	.KEY, WOODRUFF .CUNA WOODRUFF	1	1	1	1	
30	69P-W0078-0A	CHROME PUMP KIT ESTUCHE REPARACION BOMBA AGUA	1	1	1	1	
31	69P-44322-40	.INSERT, CARTRIDGE .CARTUCHO	1	1	1	1	
32	61N-44323-40	.OUTER PLATE, CARTRIDGE .PLACA EXTERIOR DEL CARTUCHO	1	1	1	1	
<hr/>							
<hr/>							
<hr/>							
<hr/>							
<hr/>							
<hr/>							
<hr/>							

NUMERICAL INDEX
INDICE NUMERICO

PART NO. CODIGO N°	REF. NO.	PART NO. CODIGO N°	REF. NO.	PART NO. CODIGO N°	REF. NO.	PART NO. CODIGO N°	REF. NO.	PART NO. CODIGO N°	REF. NO.	PART NO. CODIGO N°	REF. NO.
61N-11111-01-1S	2 - 19	69S-14237-00	30 - 7	61N-15758-01-4D	7 - 18	61N-41123-00-1S	2 - 34	682-42525-00	12 - 19	6G5-43145-01	19 - 9
61T-11111-01-1S	2 - 19	69S-14291-00	30 - 10	61N-15762-00	7 - 19	6K8-41124-A1	2 - 37	648-42528-00	20 - 1	689-43160-00	19 - 19
61N-11181-A1	2 - 21	69S-14292-00	30 - 11	6F5-15764-00	7 - 15		31 - 9	69R-42610-20-4D	1 - 1	689-43165-00	19 - 20
	31 - 5	69P-14301-00	5 - 1	61T-15770-00	7 - 36	69P-41131-01-5B	21 - 6	69S-42610-20-4D	1 - 1	689-43191-00	19 - 14
61N-11191-01-1S	2 - 22	69S-14301-00	5 - 1	6H7-15771-01-94	7 - 29	69P-41131-11-5B	21 - 6	60B-42610-H0-4D	1 - 1	689-43192-01	19 - 15
61T-11193-A1	2 - 23	664-14321-01	5 - 13	656-15772-00-94	7 - 31	69P-41134-A0	21 - 7	69P-42610-H0-4D	1 - 1	689-43311-03-4D	19 - 27
	31 - 6	61N-14323-00	5 - 19	61T-15772-01-94	7 - 31		32 - 3	69P-42613-00-4D	1 - 7	682-43318-01	19 - 44
689-11325-00	2 - 17	6A0-14325-00	6 - 26	69P-15774-00	7 - 39	6A8-41135-00	21 - 14	6G0-42615-00	1 - 2	689-43373-01	20 - 2
6J8-11325-00	2 - 12	61N-14341-00	5 - 9	6F5-15779-02	7 - 17		32 - 4	61N-42628-00	1 - 10	689-43614-01	19 - 38
6H3-11327-00-1S	2 - 13	61T-14341-00	5 - 9	6A0-15789-00	7 - 22	69P-41137-00-5B	21 - 9	689-42647-00	1 - 3	648-43615-00	19 - 39
6H3-11328-00	2 - 14	6L2-14342-34	5 - 11	6YJ-24167-00	24 - 7	69P-41138-00	21 - 12	6G0-42651-02	1 - 5	689-43616-00	19 - 33
676-11372-00	2 - 20	61N-14343-65	5 - 10	6YJ-24201-00	24 - 1		32 - 18	69R-42677-00	1 - 12	648-43617-00	19 - 36
69P-11400-00	3 - 1	50M-14355-00	5 - 12	6YJ-24201-10	24 - 1	69P-41139-00	21 - 13	69S-42677-00	1 - 12	69P-43625-00	20 - 52
69P-11412-00	3 - 2		31 - 23	6YJ-24260-00	24 - 3		32 - 19	69P-42677-H0	1 - 12	689-43631-00	19 - 30
61N-11422-00	3 - 3	61N-14381-00	5 - 2	6Y1-24260-12	24 - 3	69P-41213-00	16 - 18	61R-42678-10	1 - 13	689-43633-00	19 - 31
61N-11432-00	3 - 4	677-14383-01	5 - 15	6Y1-24268-00	24 - 6	682-41237-00	16 - 12	61T-42678-10	1 - 13	648-43642-00	19 - 34
61N-11442-00	3 - 5	6L2-14384-00	5 - 20	6G1-24304-02	6 - 1	662-41237-01	16 - 7	60B-42678-H0	1 - 13	689-43643-00	19 - 32
61N-11515-00	3 - 10		31 - 13	6G1-24305-05	24 - 13	682-41238-01	16 - 11	61N-42678-H0	1 - 13	689-43681-01	19 - 43
61N-11603-00	3 - 19	6L2-14385-00	5 - 5	6Y1-24305-06	24 - 15	69P-41241-00	16 - 20	689-42711-04-4D	14 - 1	689-44111-01-4D	16 - 30
61N-11604-00	3 - 19		31 - 21	61J-24306-04	24 - 8	679-41241-01	16 - 9	664-42715-00	16 - 26	664-44113-01	16 - 31
61N-11605-00	3 - 19	6E5-14386-01	5 - 4	689-24311-00	6 - 14	689-41252-01	4 - 20	69P-42716-00	20 - 25	689-44121-01	16 - 38
61N-11631-00-95	3 - 18		31 - 20	6A1-24311-00	6 - 31	61N-41256-00	4 - 21	65W-42717-00	21 - 2	689-44125-00	16 - 39
689-11633-00	3 - 20	61N-14392-00	5 - 3	61N-24329-00	6 - 2	661-41262-02	4 - 22	69P-42717-00	20 - 24	664-44142-00	16 - 33
688-11634-00	3 - 22		31 - 19	6Y1-24329-00	24 - 5	682-41271-00	4 - 17	689-42718-00	20 - 21	61N-44143-00	16 - 43
61N-11635-00	3 - 18	6L2-14398-00	5 - 16	650-24351-01	24 - 12	689-41273-00	4 - 18	682-42724-00	14 - 15	61N-44146-00	16 - 47
61N-11636-00	3 - 18		31 - 24	61J-24360-00	24 - 10	6J8-41274-00	4 - 19	61T-42724-40	14 - 15	61N-44150-00	22 - 62
689-11651-00	3 - 12	6L2-14399-00	5 - 8	692-24410-00	6 - 16	676-41611-00	8 - 17	676-42724-40	14 - 18	61N-44150-10	22 - 62
689-11681-01	3 - 13		31 - 22	663-24411-00	6 - 21	689-41612-01	8 - 21	689-42724-50	11 - 16	61N-44150-30	22 - 62
6E5-12411-02	2 - 26	61N-14440-00	4 - 13	692-24411-00	6 - 18	676-41613-00	8 - 18		12 - 16	664-44167-01	16 - 27
6E5-12412-00	2 - 27	69P-14497-00	16 - 1	6A0-24412-02	6 - 27	61N-41615-00	9 - 1	689-42725-01	14 - 16	61N-44176-00	22 - 19
655-12413-01-1S	2 - 29	62Y-14597-00	5 - 23	6A0-24413-00	6 - 17	69P-41631-00	16 - 2	6E7-42791-00	14 - 23	6E0-44191-11	1 - 15
655-12414-A1	2 - 30	69P-15100-00-1S	2 - 2	6A0-24421-01	6 - 25	689-42111-01-4D	15 - 2	6G5-42791-00	14 - 23	61N-44194-01	9 - 2
	31 - 7	689-15396-01-5B	2 - 6	650-24431-A0	6 - 28	69P-42112-00-4D	15 - 7	6E7-42791-10	14 - 23	61T-44194-01	9 - 2
69S-12466-00-94	30 - 5	61N-15711-10	7 - 2		31 - 17	664-42119-00	15 - 11	6G5-42791-10	14 - 23	69P-44311-00	22 - 10
677-13437-0B	1 - 14	6F5-15713-01	7 - 5	648-24434-01	6 - 19	656-42126-01	15 - 20	6A1-42792-01	14 - 24		32 - 21
61N-13610-00	4 - 1	6G0-15714-01	7 - 3	648-24435-02	6 - 22	6G1-42137-10	15 - 14	6G0-42796-00	14 - 5	69P-44322-00	22 - 12
689-13610-01	4 - 1	61N-15715-00	7 - 6	61N-24521-00	6 - 9	689-42138-00	15 - 19	689-42815-00	14 - 10		32 - 23
648-13621-A1	4 - 3	6F5-15716-01	7 - 8	61N-24560-00	6 - 7	656-42153-00-94	16 - 15	689-42816-00	14 - 13	69P-44322-40	22 - 12
	31 - 15	6F5-15723-01	7 - 34	61N-24563-00	6 - 8	69P-42154-00	16 - 21	689-43111-03-4D	19 - 1		32 - 31
61N-13641-01-1S	4 - 4	6F5-15726-01	7 - 11	61N-24566-01	6 - 12	69P-42157-00-94	16 - 14	689-43112-02-4D	19 - 2	61N-44323-00	22 - 15
648-13645-A0	4 - 5	61N-15734-00	7 - 7	6YJ-24610-01	24 - 2	69P-42167-00	16 - 19	6J8-43113-01	19 - 13		32 - 26
	31 - 10	6F5-15739-00	7 - 16	61N-26311-00	15 - 23	62Y-42171-00	16 - 22	6F5-43114-00	19 - 6	61N-44323-40	22 - 15
6L2-14157-00	5 - 7	6F5-15741-01	7 - 4	61N-26326-00	14 - 18	6F6-42177-A0	15 - 12	648-43114-01	19 - 6		32 - 32
61N-14198-00	4 - 12	69P-15746-00	7 - 41	6A1-28176-00	14 - 25	69P-42511-00-4D	20 - 4	6G0-43116-00	19 - 5	65W-44328-11	22 - 18
	31 - 11	689-15747-70	7 - 42	61H-2819R-31	6 - 33	689-42521-00-94	20 - 7	6E0-43118-01	19 - 3	6H4-44352-02	22 - 13
61N-14212-00	5 - 21	656-15748-00	7 - 37	6K8-41121-00-1S	2 - 32	647-42523-00	14 - 17	663-43118-01-4D	19 - 3		32 - 24
646-14212-01	5 - 18	6G0-15754-00	7 - 9	6K8-41122-A1	2 - 33	682-42525-00	10 - 19	6J8-43131-01	19 - 8	61N-44361-00	23 - 1
69S-14227-00	30 - 6	689-15755-01	7 - 14		31 - 8		11 - 19	6E5-43145-01	25 - 9	61N-44361-10	23 - 1

NUMERICAL INDEX
INDICE NUMERICO

PART NO. CODIGO N°	REF. NO.	PART NO. CODIGO N°	REF. NO.	PART NO. CODIGO N°	REF. NO.	PART NO. CODIGO N°	REF. NO.	PART NO. CODIGO N°	REF. NO.	PART NO. CODIGO N°	REF. NO.
61N-44361-30	23 - 1	61N-45510-00	22 - 36	703-48189-00	27 - 17	703-48261-11	27 - 2	648-48534-50-4D	17 - 5	61N-82317-00	9 - 6
61N-44362-00	22 - 7	61N-45510-10	22 - 36	701-48189-11	28 - 31	703-48264-00	27 - 6		18 - 6	66T-82370-00	9 - 29
61N-44362-10	22 - 7	61N-45510-30	22 - 36	701-48196-11	28 - 7	703-48265-00	27 - 9	689-61350-02	25 - 1	663-82370-01	9 - 29
689-44366-00	23 - 2	61N-45536-00	22 - 5	701-48197-10	28 - 3	701-48266-00	28 - 29	689-61351-01	25 - 2	6G1-82370-21	9 - 29
	32 - 5	61N-45551-00	22 - 38	61N-45551-00	22 - 38	701-48268-00	28 - 18	6E5-61355-00	25 - 7	689-82510-04	29 - 3
6L2-44367-00	22 - 11	61N-45560-10	22 - 42	701-48198-10	28 - 15	703-48268-00	27 - 5	61N-81313-09	8 - 4	703-82510-33	27 - 43
	32 - 7	6L2-45567-00	22 - 41	703-48211-01	27 - 60	703-48271-00	27 - 59	6E9-81328-70	8 - 7	61N-82519-01	9 - 10
664-44514-00-94	20 - 35	6L2-45567-10	22 - 41	703-48212-00	27 - 57	701-48271-10	28 - 34	689-81800-13	13 - 1	69S-8251S-00	30 - 21
689-44516-00	20 - 30	6L2-45567-20	22 - 41	701-48213-00	28 - 19	701-48280-00	28 - 44	689-81807-12	13 - 3	703-82531-00	27 - 45
69P-44518-00-94	20 - 14	6L2-45567-30	22 - 41	703-48213-00	27 - 58	703-48281-00	27 - 30	689-81809-11	13 - 7	689-82531-02	10 - 6
648-44519-00-94	20 - 16	6L2-45567-40	22 - 41	703-48215-00	27 - 42	701-48281-10	28 - 16	689-81810-11	13 - 9		11 - 5
689-44551-01-4D	20 - 43	61N-45571-00	22 - 50	703-48219-00	27 - 29	701-48282-00	28 - 28	689-81811-11	13 - 12		12 - 5
689-44552-01-4D	20 - 45	6L2-45577-00	22 - 51	701-48221-00	28 - 6	703-48282-00	27 - 31	689-81812-11	13 - 11	703-82540-00	27 - 49
689-44553-00-94	20 - 39	6L2-45577-10	22 - 51	703-48221-00	27 - 55	703-48284-00	27 - 51	689-81813-10	13 - 13	689-82540-01	10 - 14
689-44555-00	20 - 44	6L2-45577-20	22 - 51	701-48222-00	28 - 27	701-48287-00	27 - 41	689-81820-11	13 - 14		12 - 30
689-44557-00	20 - 40	6L2-45577-30	22 - 51	703-48222-00	27 - 26		28 - 42	689-81826-10	13 - 15	682-82556-00	14 - 20
648-44591-A0	20 - 29	61N-45587-00	22 - 4	703-48223-00	27 - 27	702-48288-00	28 - 23	689-81830-11	13 - 4		27 - 47
664-44591-A0	20 - 36	61N-45587-10	22 - 4	703-48224-00	27 - 54	701-48289-00	28 - 17	689-81831-00	13 - 5		29 - 6
69P-45111-00-4D	21 - 1	61N-45587-20	22 - 4	703-48225-00	27 - 28	703-48291-10	27 - 38	689-81840-11	13 - 10	61T-82560-00	11 - 30
69P-45111-10-4D	21 - 1	61N-45587-30	22 - 4	703-48226-00	27 - 25	703-48293-10	27 - 40	689-81847-11	13 - 6	689-82570-1B	29 - 1
689-45113-A1	2 - 42	61N-45587-40	22 - 4	703-48227-00	27 - 24	701-48320-20	26 - 3	689-81850-12	13 - 8	704-82571-02	29 - 2
	31 - 14	61N-45587-50	22 - 4	701-48229-00	28 - 26	701-48320-50	26 - 3	689-81857-11	13 - 2	688-82575-01	27 - 46
	32 - 2	61N-45587-60	22 - 4	703-48230-15	26 - 1	648-48330-50	17 - 20	689-81870-00	10 - 16		29 - 5
663-45119-00	19 - 18	61N-45587-70	22 - 4		27 - 1		18 - 15	6H3-81922-00	9 - 18	6E9-82575-02	14 - 19
	20 - 23	65W-45611-00	22 - 43	701-48232-00	28 - 30	617-48331-91	17 - 21	67F-81930-00	30 - 12	703-82577-00	27 - 44
61N-45127-00	22 - 26	664-45631-02	22 - 45	703-48232-00	27 - 61		18 - 19	6G1-81941-10	10 - 3		29 - 4
	32 - 11	648-45633-00	22 - 47	701-48234-00	28 - 5	648-48340-50	17 - 14		11 - 2	6E3-8257H-00	14 - 26
69P-45127-00	21 - 17	648-45635-00	22 - 44	703-48234-00	27 - 18		18 - 9		12 - 2	689-8257Y-00	14 - 21
69P-45128-00	21 - 18	62C-45941-00-EL	23 - 17	701-48235-00	28 - 2	703-48345-01	27 - 19	61T-81945-01	10 - 5	61T-82580-00	11 - 13
69P-45151-00	20 - 49	664-45941-01-EL	23 - 17	703-48235-00	27 - 4		28 - 36		11 - 4		12 - 13
69P-45159-00	21 - 20	664-45943-01-EL	23 - 17	701-48236-00	28 - 8	648-48346-50	17 - 22		12 - 4	64D-82581-00	29 - 7
61N-45211-31-4D	21 - 23	664-45945-00-EL	23 - 17	703-48236-00	27 - 16		18 - 16	6G1-81952-00	10 - 4	688-82586-21	27 - 48
6L2-45214-00	23 - 8	664-45947-01-EL	23 - 17	702-48237-00	28 - 9	617-48346-90	17 - 16		11 - 3	688-82586-50	29 - 12
6L2-45215-00	23 - 9	664-45949-02-EL	23 - 17	702-48238-00	28 - 10		18 - 10		12 - 3	61T-82588-00	11 - 31
61N-45251-01	22 - 31	664-45952-00-EL	23 - 17	703-48238-00	27 - 22	701-48358-00	28 - 38	664-81970-61	10 - 7	61T-82590-00	11 - 14
69P-45300-01-4D	22 - 1	664-45954-01-EL	23 - 17	701-48243-00	28 - 14	703-48358-00	27 - 20		11 - 6		12 - 14
69P-45300-11-4D	22 - 1	6L2-45987-01	23 - 12	703-48243-00	27 - 15	617-48361-91	17 - 15		12 - 6	703-82591-00	27 - 52
69P-45300-31-4D	22 - 1	689-45997-00	23 - 13	703-48244-00	27 - 21		18 - 13	689-81971-00	10 - 2	703-82592-00	27 - 53
61N-45311-02-4D	22 - 2	69P-47467-00-5B	21 - 16	703-48245-00	27 - 11	689-48501-01-4D	18 - 1	69S-81971-00	30 - 27	689-82594-00	10 - 18
61N-45315-00	22 - 27	69P-47467-10-5B	21 - 16	701-48246-00	28 - 24	689-48501-21-4D	18 - 1	689-82105-13	10 - 17	689-82594-10	11 - 18
	32 - 10	701-48102-51	26 - 2	703-48246-00	27 - 23	700-48510-12	17 - 26		11 - 15		12 - 18
689-45318-00	21 - 24		28 - 1	701-48248-00	27 - 13		18 - 21		12 - 15	69W-83354-00	30 - 3
61N-45321-00	22 - 20	701-48133-00	28 - 40		28 - 12	689-48511-01	17 - 1	682-82150-10	10 - 12	703-83383-02	27 - 50
61N-45331-00-5B	22 - 24	701-48138-50	28 - 39	701-48249-00	28 - 11		18 - 22		11 - 11	6A1-83625-41	4 - 25
688-45341-10	22 - 34	703-48152-00	27 - 56	701-48252-00	28 - 4	689-48531-50	17 - 11		12 - 11	61T-83625-80	4 - 26
61N-45361-01-4D	22 - 52	701-48152-20	28 - 13	703-48252-00	27 - 12		18 - 2	663-82151-00	10 - 13	6E0-83627-01	30 - 26
61N-45371-00	23 - 6	703-48153-00	27 - 3	701-48255-00	28 - 21	689-48532-50	17 - 8		11 - 12	6E0-83627-41	15 - 25
61N-45375-00	21 - 21	701-48153-12	28 - 33	701-48261-10	28 - 37		18 - 3		12 - 12	61T-83627-80	15 - 24

NUMERICAL INDEX
INDICE NUMERICO

PART NO. CODIGO N°	REF. NO.	PART NO. CODIGO N°	REF. NO.	PART NO. CODIGO N°	REF. NO.	PART NO. CODIGO N°	REF. NO.	PART NO. CODIGO N°	REF. NO.	PART NO. CODIGO N°	REF. NO.
69S-83790-01	30 - 1	90109-06M18	19 - 45	90201-10M63	25 - 8	90387-33001	15 - 4	91490-30022	23 - 16	92995-06600	20 - 19
69S-83793-00	30 - 2	90116-10M33	21 - 22	90201-16M44	8 - 16	90430-08020	22 - 30	91490-30025	21 - 15		22 - 17
6E9-85516-70	8 - 9	90119-06024	21 - 19	90201-20417	22 - 49		32 - 13	91690-30008	19 - 21		30 - 15
663-85518-00	16 - 10	90119-06025	7 - 33	90201-20M27	3 - 23	90445-09M75	6 - 5	91690-30012	17 - 17		32 - 28
61N-85537-00	8 - 13	90119-06M17	16 - 25	90201-21567	2 - 28	90445-10M41	2 - 36		18 - 14	92995-08600	20 - 42
61N-85540-13	9 - 13	90119-06M23	7 - 43	90201-22M03	19 - 11	90445-11M05	24 - 11	91690-30016	19 - 16		21 - 5
69P-85541-09	8 - 3	90119-06M48	23 - 7	90201-28013	15 - 5	90445-11M06	24 - 9	91690-40016	16 - 42	92995-10600	21 - 27
61N-85542-00-94	9 - 5	90119-06M73	14 - 14	90201-50306	2 - 41	90445-22002	20 - 53	91690-40018	16 - 17		23 - 5
61N-85543-09	8 - 5	90119-06M94	4 - 15	90202-06007	16 - 35	90446-06M90	30 - 4	91690-40035	19 - 47	93101-16001	2 - 8
61N-85543-19	8 - 6	90119-06M95	9 - 8	90202-10024	16 - 41	90446-10M02	10 - 15	91690-40048	4 - 23		31 - 3
69W-85546-00	30 - 13	90119-06MA0	2 - 40	90206-05005	7 - 45		12 - 31	92780-06025	28 - 20	93101-20M07	22 - 56
61N-85550-10	8 - 1	90119-06MA2	2 - 24	90206-12052	14 - 11	90465-06M88	4 - 24	92903-05600	7 - 46		32 - 15
61T-85550-10	8 - 1	90119-06MA3	2 - 38	90206-28001	15 - 6	90465-13M11	9 - 19	92903-06600	2 - 16	93101-22067	22 - 28
69P-85560-00	8 - 2		7 - 30	90209-24M03	3 - 15	90465-13M97	30 - 28		4 - 7		32 - 12
69P-85561-00	8 - 10	90119-06MA4	2 - 39	90209-47016	20 - 9	90465-18147	11 - 29	92903-08600	13 - 17	93102-25008	2 - 7
61N-85570-00	9 - 20		7 - 32	90240-05047	19 - 40		12 - 29	92903-10600	15 - 16		31 - 2
6H5-85570-00	9 - 20	90119-08009	2 - 3	90243-04007	19 - 4	90467-08004	6 - 6	92990-04600	30 - 9	93102-32M07	3 - 7
61N-85570-10	9 - 25	90119-08015	2 - 25	90243-04M01	19 - 4	90480-10155	11 - 25	92990-05100	6 - 24	93210-03261	11 - 28
61T-86111-00	11 - 21	90119-08061	20 - 51	90249-06M22	19 - 35		12 - 25		29 - 10		12 - 28
	12 - 21	90119-08M03	20 - 47	90250-05010	22 - 46	90480-10M23	30 - 17	92990-05600	8 - 20	93210-06ME6	22 - 21
61T-86112-00	11 - 24	90119-08M65	2 - 4	90266-04M00	1 - 6	90480-14M14	1 - 9		10 - 9		32 - 9
	12 - 24	90149-05M05	29 - 8	90266-04M01	1 - 4	90480-15M06	14 - 2		11 - 8	93210-08287	24 - 14
682-86116-00	11 - 22	90149-05M13	15 - 13	90269-02M09	15 - 15	90480-17165	11 - 17		12 - 8	93210-16275	25 - 10
	12 - 22	90149-14030	19 - 5	90280-03M03	22 - 37		12 - 17		16 - 37	93210-22164	22 - 8
682-86117-00	11 - 23	90151-05M05	23 - 10		32 - 29	90480-17M08	10 - 1		29 - 11		32 - 17
	12 - 23	90151-06M02	2 - 18	90280-05015	8 - 14		11 - 1	92990-06100	9 - 12	93210-26130	22 - 9
69P-W0001-00	31 - 1	90161-06M00	10 - 20	90340-08002	22 - 29		12 - 1		10 - 11		32 - 6
69P-W0001-20	32 - 1		11 - 20	90381-12M01	20 - 20		14 - 22		11 - 10	93210-32738	6 - 10
689-W0004-00	4 - 2		12 - 20	90386-08032	15 - 18	90480-25161	9 - 26		12 - 10		31 - 16
61R-W0070-10	1 - 11	90170-09M03	25 - 5	90386-10009	16 - 16	90480-29045	20 - 5	92990-06300	22 - 33	93210-37160	20 - 12
60B-W0070-H0	1 - 11	90170-10M42	20 - 27	90386-12069	14 - 12	90501-09M08	16 - 29		28 - 25	93210-40659	4 - 14
61N-W0070-H0	1 - 11	90171-14013	23 - 15	90386-22M67	19 - 12	90501-10065	22 - 48	92990-06600	30 - 25		31 - 12
69P-W0078-00	32 - 20	90176-10M01	20 - 38	90386-38022	20 - 13	90501-10071	17 - 24	92990-08600	14 - 8	93210-45161	22 - 14
69P-W0078-0A	32 - 30	90179-06M24	1 - 8	90386-38090	20 - 11		18 - 18		17 - 19		32 - 8
69P-W0084-00-4D	15 - 1	90179-10M03	21 - 26	90386-47M22	20 - 10	90501-10227	7 - 38		18 - 11	93210-46M16	3 - 8
69P-W0090-00-1S	2 - 1	90179-10M14	22 - 39	90387-06013	7 - 44	90501-10264	17 - 18		19 - 25	93210-58M21	2 - 9
69S-W0090-00-1S	2 - 1	90179-16M05	8 - 15	90387-06119	9 - 7		18 - 12		27 - 33		31 - 4
61N-W0093-00	31 - 18	90185-05002	23 - 11	90387-06M26	4 - 16	90501-14M07	16 - 28	92990-10200	20 - 28	93210-64ME7	22 - 54
61N-W1571-11	7 - 1	90185-06062	15 - 22	90387-06M59	16 - 3	90501-23215	15 - 17	92990-10600	17 - 3		32 - 14
656-W2810-02	6 - 34	90185-09M01	25 - 4	90387-06M60	16 - 24	90502-10M07	19 - 22		18 - 24	93210-65M50	22 - 57
90101-08339	19 - 23	90185-10051	17 - 4	90387-06M64	30 - 16	90506-16M17	19 - 46	92990-14200	23 - 14		32 - 16
90105-06M07	16 - 32		18 - 25	90387-08019	20 - 50	90506-30M27	19 - 42	92995-06600	2 - 11	93306-00612	22 - 53
	20 - 6	90185-22043	19 - 10	90387-08M03	19 - 24	90508-14M13	16 - 40		6 - 4	93306-305U3	3 - 9
90105-06M08	20 - 26	90201-06416	16 - 5	90387-08M25	14 - 3	91490-12010	16 - 36		7 - 21	93310-62406	3 - 14
90105-06M18	20 - 3	90201-06M30	9 - 9	90387-10M39	20 - 15	91490-16010	7 - 47		9 - 4	93315-22004	22 - 55
90105-08M10	7 - 35	90201-06M62	30 - 18	90387-10M42	25 - 6		16 - 23		15 - 10	93315-220V7	22 - 6
90105-10M12	23 - 4	90201-08M87	14 - 4	90387-13003	15 - 3		19 - 41		17 - 7	93332-00005	22 - 40
90109-06M12	19 - 7	90201-10M20	25 - 3	90387-32002	3 - 16		16 - 46		18 - 5	93332-000W5	22 - 3

NUMERICAL INDEX
INDICE NUMERICO

PART NO. CODIGO N°	REF. NO.	PART NO. CODIGO N°	REF. NO.	PART NO. CODIGO N°	REF. NO.	PART NO. CODIGO N°	REF. NO.	PART NO. CODIGO N°	REF. NO.	PART NO. CODIGO N°	REF. NO.
93390-00009	3 - 17	97090-06012	9 - 11	97980-04112	5 - 11						
93399-99951	3 - 6		10 - 10	98503-04006	11 - 26						
93430-06024	27 - 10		11 - 9		12 - 26						
	28 - 35		12 - 9	98503-05028	6 - 23						
93440-62057	3 - 11	97095-06010	7 - 40	98580-03015	27 - 37						
93602-20M02	3 - 21		9 - 3	98580-04006	27 - 35						
93604-10M03	22 - 25	97095-06012	16 - 6	98580-04010	27 - 34						
93606-11M24	21 - 25		17 - 6	98580-05010	27 - 36						
	23 - 3		18 - 7		28 - 32						
93606-12019	2 - 5	97095-06016	7 - 20	98580-05020	28 - 41						
	20 - 17		17 - 9	98586-05016	24 - 4						
	21 - 3		18 - 4	98980-04006	5 - 17						
93608-12063	20 - 8		30 - 14	99009-17500	11 - 32						
93700-06M03	19 - 17	97095-06018	20 - 18	99080-05600	19 - 37						
	20 - 22	97095-06020	6 - 3	99530-10014	7 - 25						
94702-00160	2 - 43		9 - 14								
94702-00217	2 - 43		15 - 9								
94702-00247	2 - 43		20 - 31								
94702-00271	2 - 43	97095-06022	2 - 10								
95303-08700	7 - 12	97095-06025	22 - 22								
95380-03600	6 - 20	97095-06035	7 - 23								
95380-05600	16 - 13	97095-06040	6 - 29								
	27 - 7		22 - 16								
	29 - 9		32 - 27								
95380-05700	16 - 8	97095-06045	16 - 4								
95380-06600	7 - 28		30 - 19								
	16 - 48	97095-08020	21 - 10								
	27 - 39	97095-08110	20 - 54								
	28 - 43	97380-05025	27 - 8								
	30 - 24	97380-08030	27 - 32								
95380-08600	6 - 11	97390-06018	28 - 22								
	19 - 26	97585-08540	14 - 6								
	20 - 46	97595-06550	15 - 8								
95380-08700	14 - 7	97595-08565	20 - 48								
95895-06035	22 - 32	97607-04112	8 - 11								
97013-06014	6 - 13	97607-06125	8 - 12								
97013-06016	2 - 15	97802-04006	8 - 8								
97013-06025	4 - 6	97880-04012	30 - 8								
97013-06035	4 - 8	97880-05012	8 - 19								
97013-06050	4 - 10		11 - 27								
97013-08012	13 - 18		12 - 27								
97013-08030	7 - 10	97880-05025	10 - 8								
	13 - 16		11 - 7								
97075-06020	22 - 58		12 - 7								
97075-08025	20 - 41	97880-06010	8 - 22								
97075-08030	21 - 4	97880-06016	21 - 8								
97075-10040	17 - 2	97890-05006	5 - 22								
	18 - 23	97980-04110	5 - 6								