



PARTS CATALOGUE

EK40GMH'17 (6F5H)



1R6F5-200EA

()

EK40GMH
PARTS CATALOGUE
©2017 by Yamaha Motor Co., Ltd.
1st edition, July 2017
All rights reserved.
Any reprinting or unauthorized use
without the written permission of
Yamaha Motor Co., Ltd.
is expressly prohibited.
Printed in Japan.

FOREWORD

This Parts Catalogue is related to the parts for the model(s) on the cover page. When you are ordering replacement parts, please refer to this Parts Catalogue and quote both part numbers and part names correctly.

1. Modifications or additions which have been made after the issue of the Parts Catalogue will be announced in the Parts News.
It is advisable that you make the necessary corrections to the Parts Catalogue according to the Parts News.

2. Abbreviations

The following abbreviations are used in this Parts Catalogue.

“UR” Use specified parts number.

“UN” Use as many as needed.

“AP” Alternate Parts

“LM” Locally Made (Parts need to be ordered locally)

“F#” Frame No. (Applicable machine No.)

“O/S” Over Size

3. The number of components for assembly

- Parts, which are to be supplied in an assembly, are listed with a dot (.) in front of the part name as shown below.
- The numeral appearing to the right of each component part indicates the quantity of parts for each assembly unit.

PART NO.	DESCRIPTION	Q'TY	REMARKS
2F5-83310-60	FRONT FLASHER LIGHT ASSY	2	
115-83311-60	.BULB (6V-18W)	1	

4. Applicable colours of graphics are represented in the “REMARKS” as shown below.

PART NO.	DESCRIPTION	Q'TY	REMARKS
2N4-24110-00-X5	FUEL TANK COMP.	2	MXR
3J1-24240-10	.GRAPHIC, FUEL TANK	1	FOR MXR

5. Note that the illustrations for reference in finding parts numbers are not to be used for assembling. When assembling, please use the applicable service manual.

6. The asterisk (*) before a reference number indicates modified items after the first edition.

7. Applicable Serial No.

Engine Serial No.

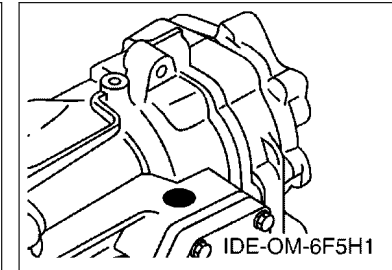
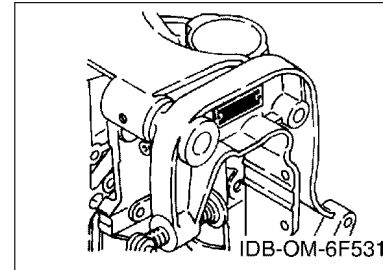

8. Applicable Engine Starting Serial No.

Model	Serial No.	Model	Serial No.
EK40G	6F5K-1023161		

9. Applicable Colour Code

Abbreviation	Colour Name	Colour Code
DBN1	DARK BLUISH GRAY 1	008D

10. Quantity Column Information

Column No.	Name Of Q'ty Column	Applicable Model
1	6F5H	EK40GMH

CONTENTS

SCHEDULED SERVICE PARTS.....	1
TOP COWLING.....	2
CYLINDER & CRANKCASE.....	3
CRANKSHAFT & PISTON.....	5
INTAKE.....	6
CARBURETOR.....	8
FUEL 1.....	10
FUEL 2.....	12
STARTER.....	13
GENERATOR.....	15
ELECTRICAL.....	16
BOTTOM COWLING.....	17
STEERING.....	18
CONTROL.....	20
BRACKET 1.....	21
BRACKET 2.....	24
UPPER CASING.....	26
LOWER CASING & DRIVE 1.....	27
LOWER CASING & DRIVE 2.....	30
FUEL TANK.....	31
REPAIR KIT 1.....	32
REPAIR KIT 2.....	34

INDEX

NUMERICAL INDEX.....	35
----------------------	----

FIG. 1 SCHEDULED SERVICE PARTS

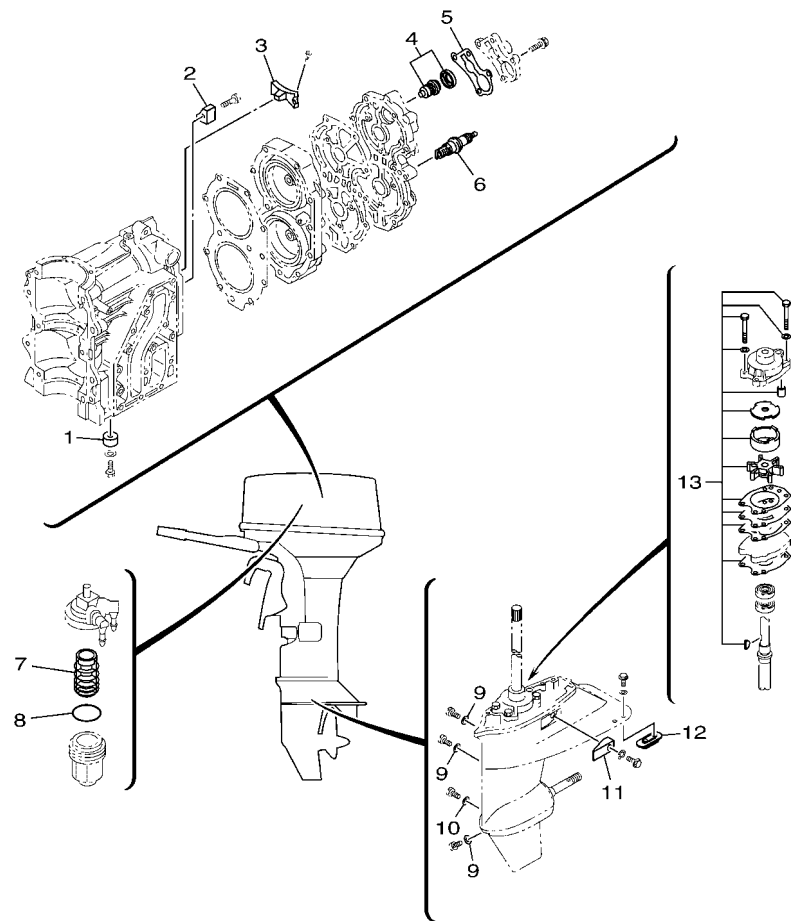

6F5D200-M010

REF. NO.	PART NO.	DESCRIPTION	6F5H				REMARKS
1	676-45251-00	ANODE	1				
2	676-11325-00	ANODE	1				
3	6F5-11325-00	ANODE	1				
4	6F5-12411-03	THERMOSTAT	1				
5	676-12414-A1	GASKET, COVER	1				
6	94702-00040	PLUG, SPARK (NGK B7HS)	2				
7	61N-24563-00	ELEMENT, FILTER	2				
8	93210-32738	O-RING	2				
9	90430-08003	GASKET	3				
10	90430-06M03	GASKET	1				
11	6F5-45251-02	ANODE	1				
12	6E0-45251-12	ANODE	1				
13	6F6-W0078-00	WATER PUMP REPAIR KIT	1				

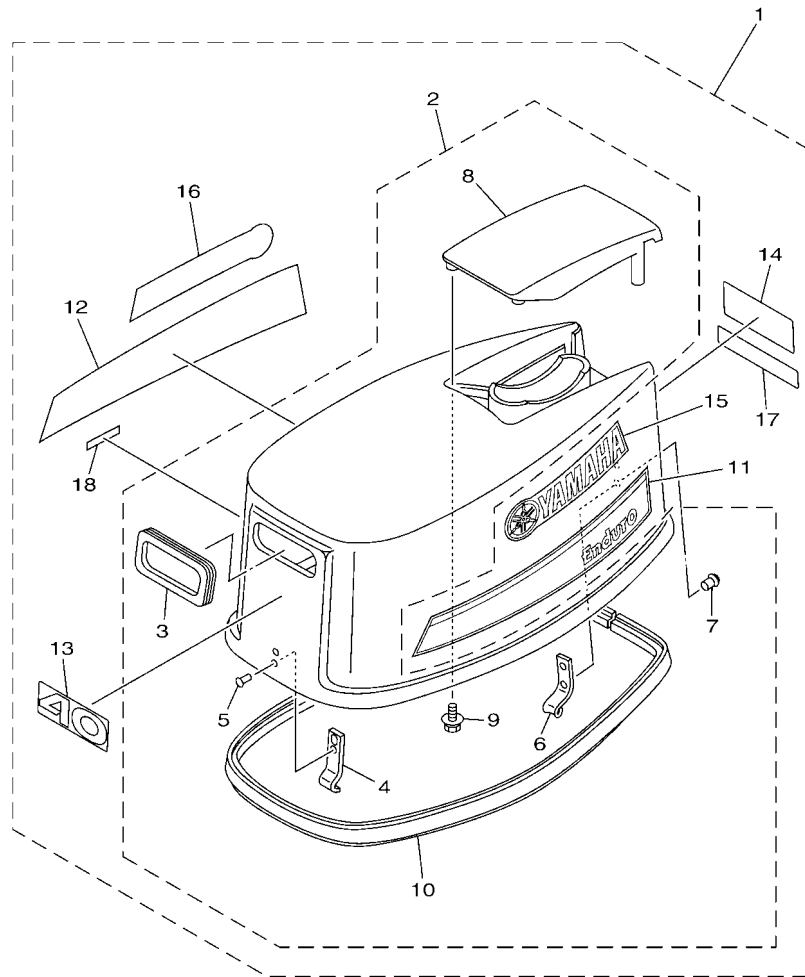

 6F5F200-P020

FIG. 2 TOP COWLING

REF. NO.	PART NO.	DESCRIPTION	6F5H				REMARKS
1	6F5-42610-10	TOP COWLING ASSY	1				
2	6F5-4261A-00	.TOP COWLING W/O GRAPHICS	1				
3	6A0-15761-00	..SEAL, RUBBER 1	1				
4	6E9-42651-01	..HOOK	1				
5	90266-04M04	..RIVET	2				
6	6F5-42652-01	..HOOK	1				
7	90266-04M01	..RIVET	2				
8	6F5-42613-A0-8D	..MOLDING, AIR DUCT	1				
9	97595-06616	..BOLT, WITH WASHER	4				
10	6F5-42615-00	..SEAL	1				
11	61N-42675-40	..GRAPHIC, SIDE 1	1				
12	61N-42676-40	..GRAPHIC, SIDE 2	1				
13	63D-42678-40	..GRAPHIC, REAR	1				
14	63D-42678-40	..GRAPHIC, REAR	1				
15	61R-42681-00	..MARK, COWLING	1				
16	61R-42681-00	..MARK, COWLING	1				
17	680-42684-00	..MARK, COWLING	1				
18	6X3-44191-00	..INDICATOR, SHIFT	1				

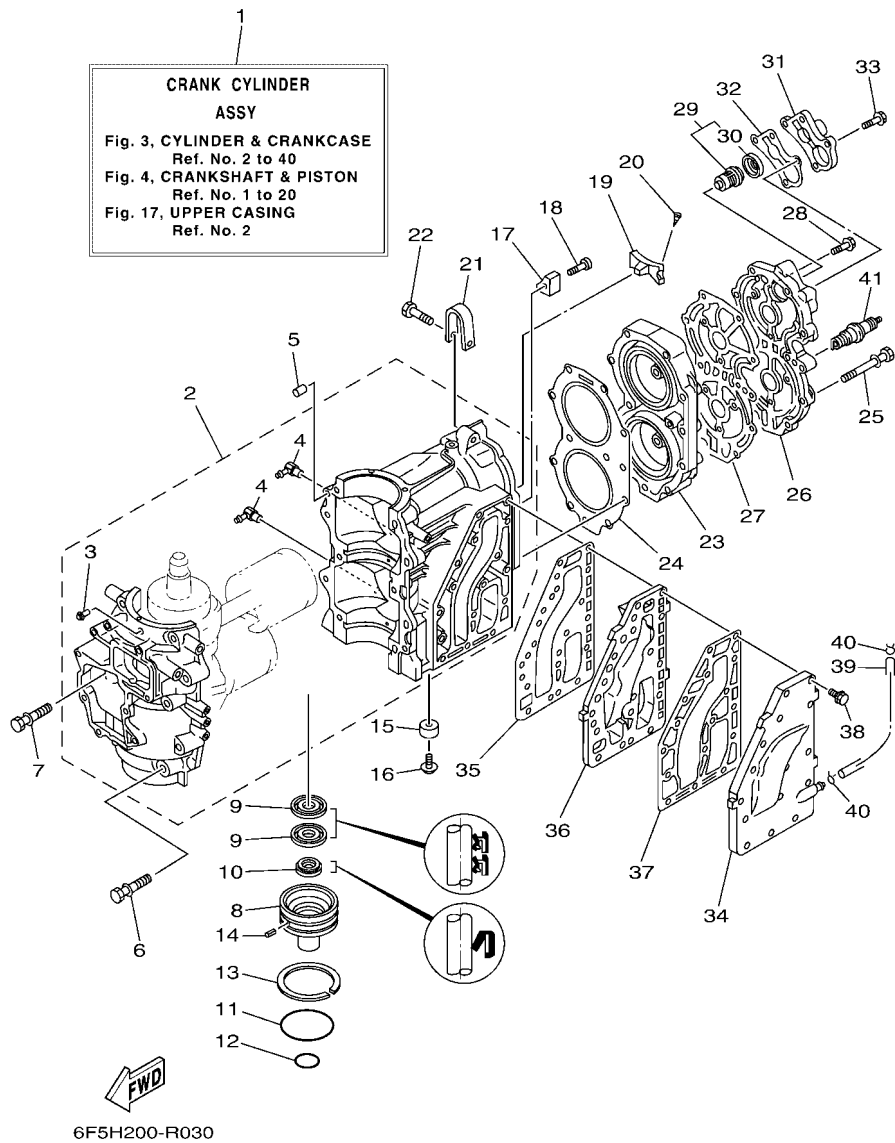

FIG. 3 CYLINDER & CRANKCASE

REF. NO.	PART NO.	DESCRIPTION	6F5H	REMARKS
1	6F5-W0090-64-1S	CRANK CYLINDER ASSY	1	
2	6F6-15100-02	CRANKCASE ASSY	1	
3	624-14485-00	.PIPE, JOINT	1	
4	650-11370-01	.CHECK VALVE ASSY	2	
5	93608-12063	PIN, DOWEL	2	
6	90119-10005	BOLT, WITH WASHER	9	
7	90119-10028	BOLT, WITH WASHER	1	
8	6F5-15396-01-CA	HOUSING, OIL SEAL	1	
9	93101-30M33	OIL SEAL	2	
10	93104-16M01	OIL SEAL	1	
11	93210-65M50	O-RING	1	
12	93210-22M02	O-RING	1	
13	93440-68M03	CIRCLIP	1	
14	91690-30010	PIN, SPRING	1	
15	676-45251-00	ANODE	1	
16	97595-06516	BOLT, WITH WASHER	1	
17	676-11325-00	ANODE	1	
18	90152-06M01	SCREW, COUNTERSUNK	1	
19	6F5-11325-00	ANODE	1	
20	97880-05030	SCREW, PAN HEAD	2	
21	6F5-11119-00	HANGER, ENGINE	1	
22	90101-08001	BOLT	1	
23	6F5-11111-00-1S	HEAD, CYLINDER 1	1	
24	6F5-11181-A2	GASKET, CYLINDER HEAD 1	1	
25	90119-08MA5	BOLT, WITH WASHER	11	
26	6F5-11191-00-1S	COVER, CYLINDER HEAD 1	1	
27	6F5-11193-A1	GASKET, HEAD COVER 1	1	

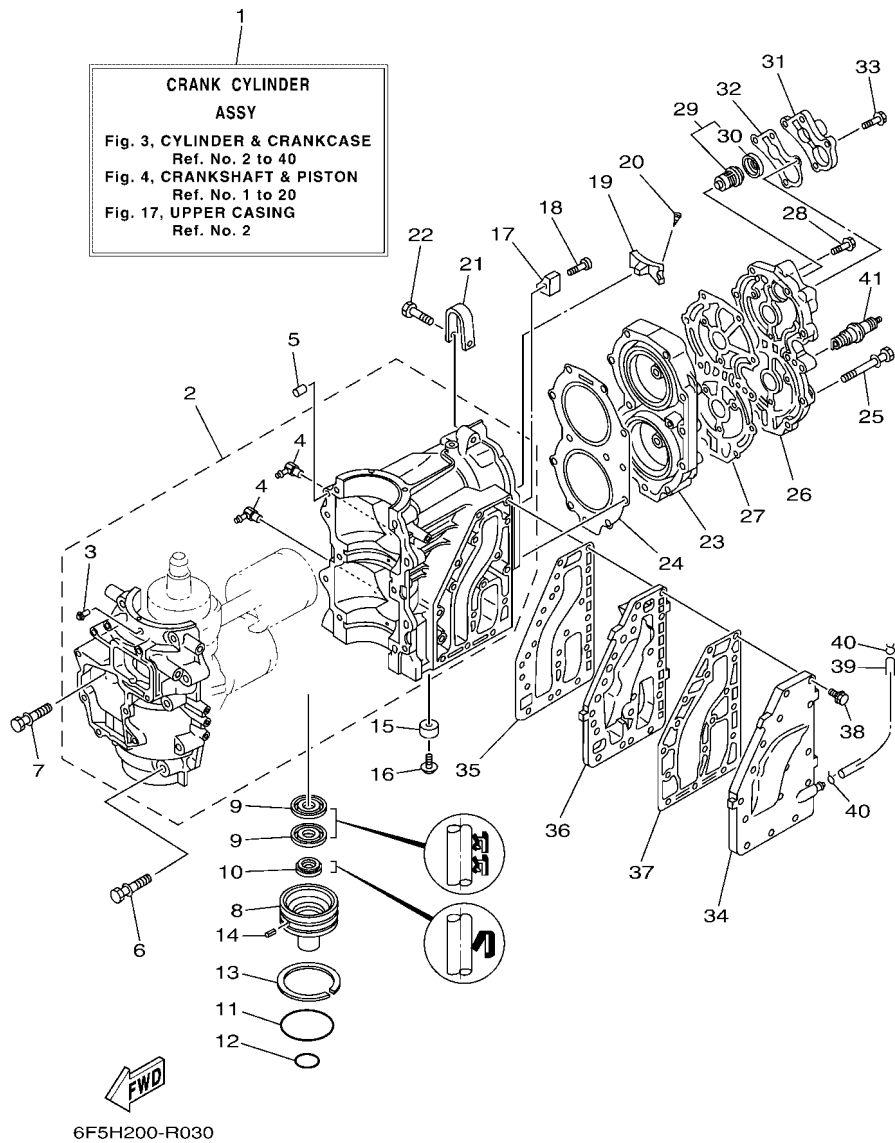
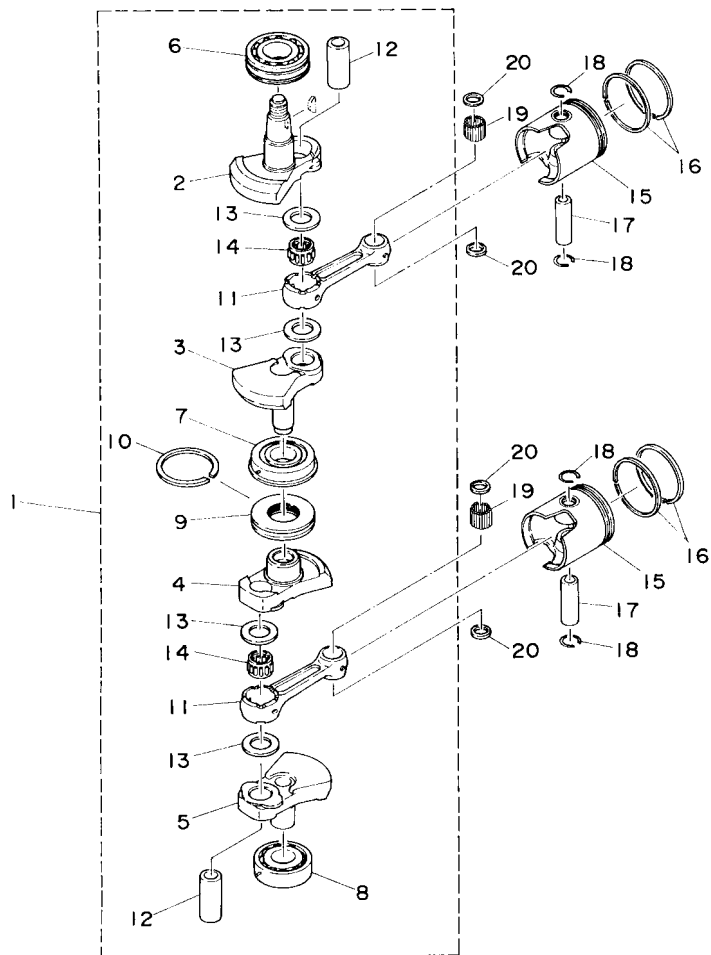

FIG. 3 CYLINDER & CRANKCASE

REF. NO.	PART NO.	DESCRIPTION	6F5H	REMARKS
28	90119-06MA3	BOLT, WITH WASHER	5	
29	6F5-12411-03	THERMOSTAT	1	
30	6E5-12412-00	.SEAL, THERMOSTAT	1	
31	676-12413-00-1S	COVER, THERMOSTAT	1	
32	676-12414-A1	GASKET, COVER	1	
33	90119-06MA2	BOLT, WITH WASHER	4	
34	6F5-41113-A0-1S	OUTER COVER, EXHAUST	1	
35	6F5-41112-A0	GASKET, EXHAUST INNER COVER	1	
36	6F5-41111-01-1S	INNER COVER, EXHAUST	1	
37	6F5-41114-A0	GASKET, EXHAUST OUTER COVER	1	
38	90119-06MA3	BOLT, WITH WASHER	16	
39	90445-09M37	HOSE (L240)	1	
40	90467-08004	CLIP	2	AP
41	94702-00040	PLUG, SPARK (NGK B7HS)	2	

FIG. 4 CRANKSHAFT & PISTON



6H90010-4030

REF. NO.	PART NO.	DESCRIPTION	6F5H				REMARKS
1	6F5-11400-11	CRANKSHAFT ASSY	1				
2	6F5-11412-11	.CRANK 1	1				
3	6F5-11422-11	.CRANK 2	1				
4	6F5-11432-11	.CRANK 3	1				
5	6F5-11442-11	.CRANK 4	1				
6	93306-307U0	.BEARING	1				
7	93332-000UE	.BEARING	1				
8	93306-306U2	.BEARING	1				
9	6F5-11515-00	.SEAL, LABYRINTH 1	1				
10	93440-68M03	.CIRCLIP	1				
11	6F5-11651-00	.ROD, CONNECTING	2				
12	6F5-11681-00	.PIN, CRANK 1	2				
13	90202-27M23	.WASHER, PLATE	4				
14	93310-727V7	.BEARING	2				
15	6F6-11631-00-95	PISTON (STD)	2				
	6F6-11635-00	PISTON (0.25MM O/S)	2				AP
	6F6-11636-00	PISTON (0.50MM O/S)	2				AP
16	6F5-11610-00	PISTON RING SET (STD)	2				
	6F5-11610-10	PISTON RING SET (0.25MM O/S)	2				AP
	6F5-11610-20	PISTON RING SET (0.50MM O/S)	2				AP
17	6F5-11633-00	PIN, PISTON	2				
18	663-11634-00	CLIP, PISTON PIN	4				
19	93603-21111	PIN, DOWEL	56				
20	90201-20417	WASHER, PLATE	4				

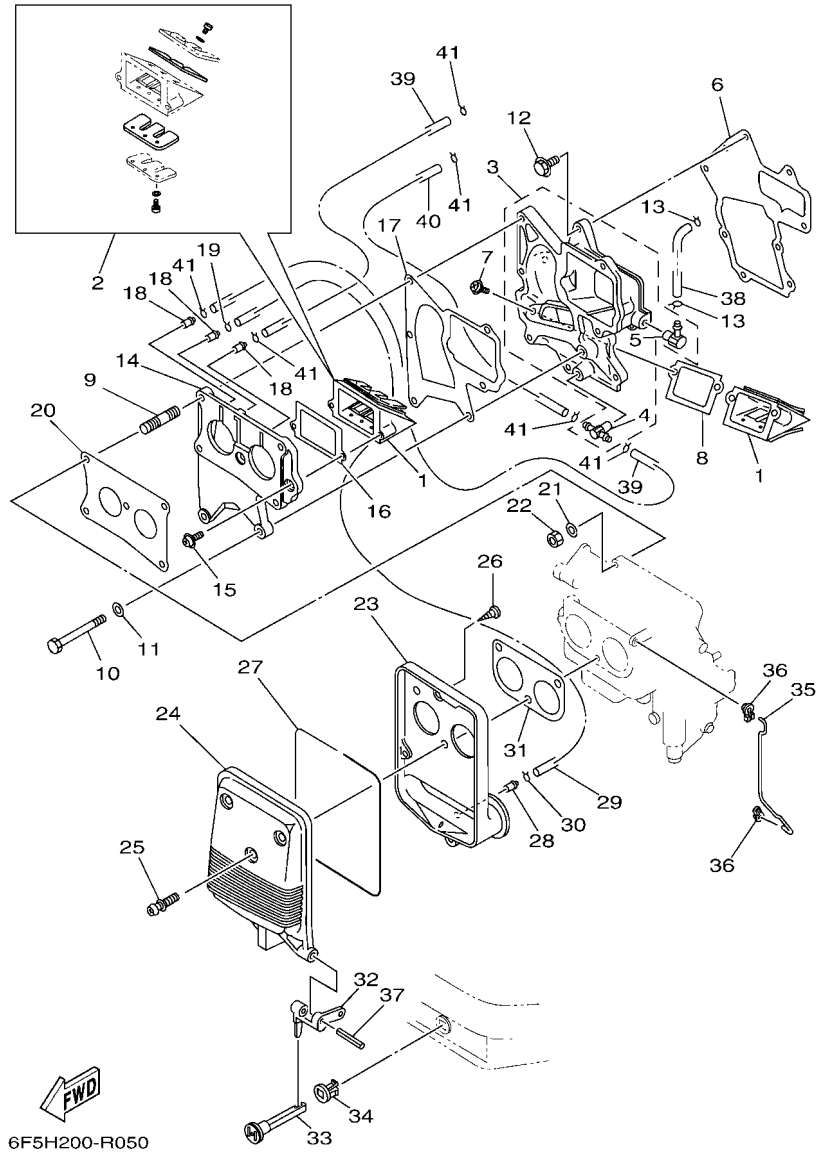

FIG. 5 INTAKE

REF. NO.	PART NO.	DESCRIPTION	6F5H				REMARKS
1	6F5-13610-00	REED VALVE ASSY	2				
2	6F5-W0004-00	.REED SET	1				
3	6F6-13641-00-1S	MANIFOLD, INTAKE 1	1				
4	6F6-11370-01	.CHECK VALVE ASSY	1				
5	650-11370-01	.CHECK VALVE ASSY	1				
6	6F5-13646-A2	GASKET, MANIFOLD 2	1				
7	97980-05114	SCREW, WITH WASHER	2				
8	6F5-13621-A1	GASKET, VALVE SEAT	1				
9	90116-06M17	BOLT, STUD	4				
10	97013-06065	BOLT	2				
11	92903-06600	WASHER, PLATE	2				
12	97513-06525	BOLT, WITH WASHER	7				
13	90467-06016	CLIP	2				
14	6F6-13643-01-1S	COVER, MANIFOLD	1				
15	97980-05114	SCREW, WITH WASHER	2				
16	6F5-13621-A1	GASKET, VALVE SEAT	1				
17	6F5-13645-A1	GASKET, MANIFOLD 1	1				
18	624-14485-00	PIPE, JOINT	3				
19	90467-06016	CLIP	1				
20	6F5-14198-A1	GASKET	1				
21	92995-06600	WASHER	4				
22	95380-06600	NUT, HEXAGON	4				
23	6F5-14417-00	COVER 1	1				
24	6F5-14418-00	COVER 2	1				
25	90159-06M01	SCREW, WITH WASHER	3				
26	97780-50716	SCREW, TAPPING	4				
27	6F5-14476-00	SEAL	1				

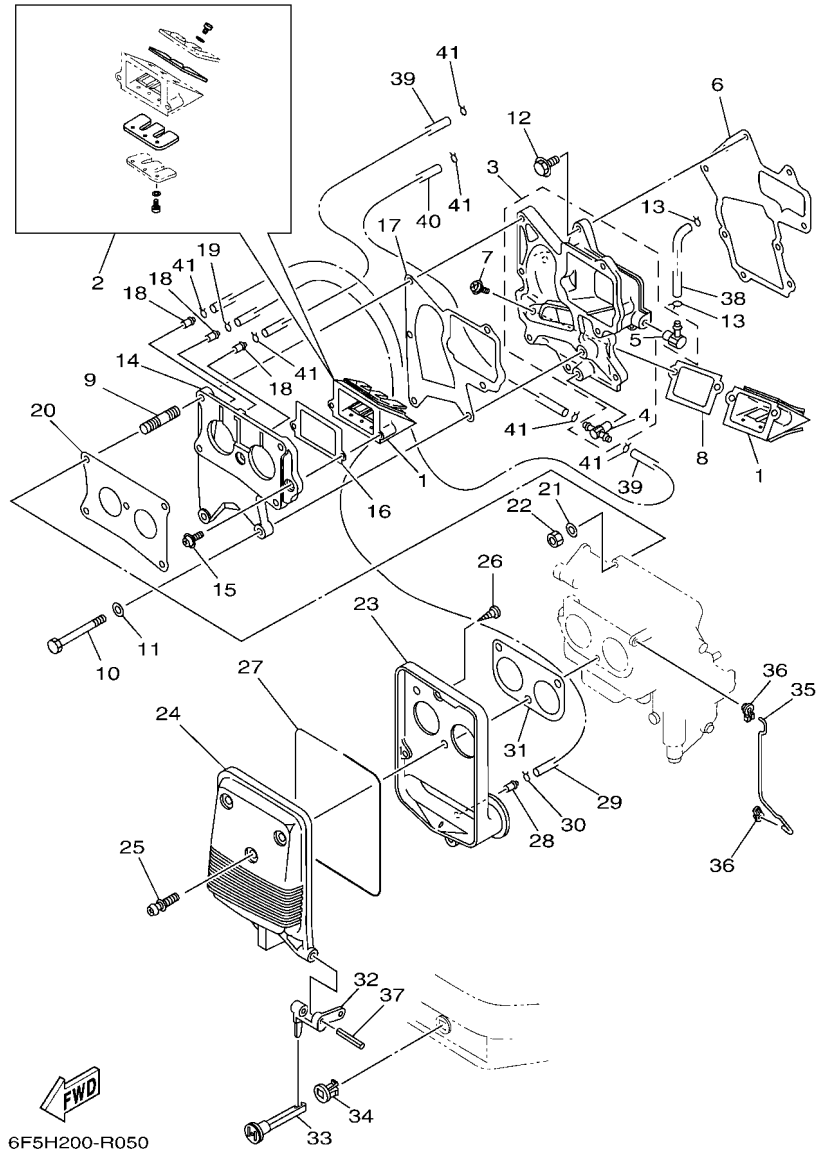
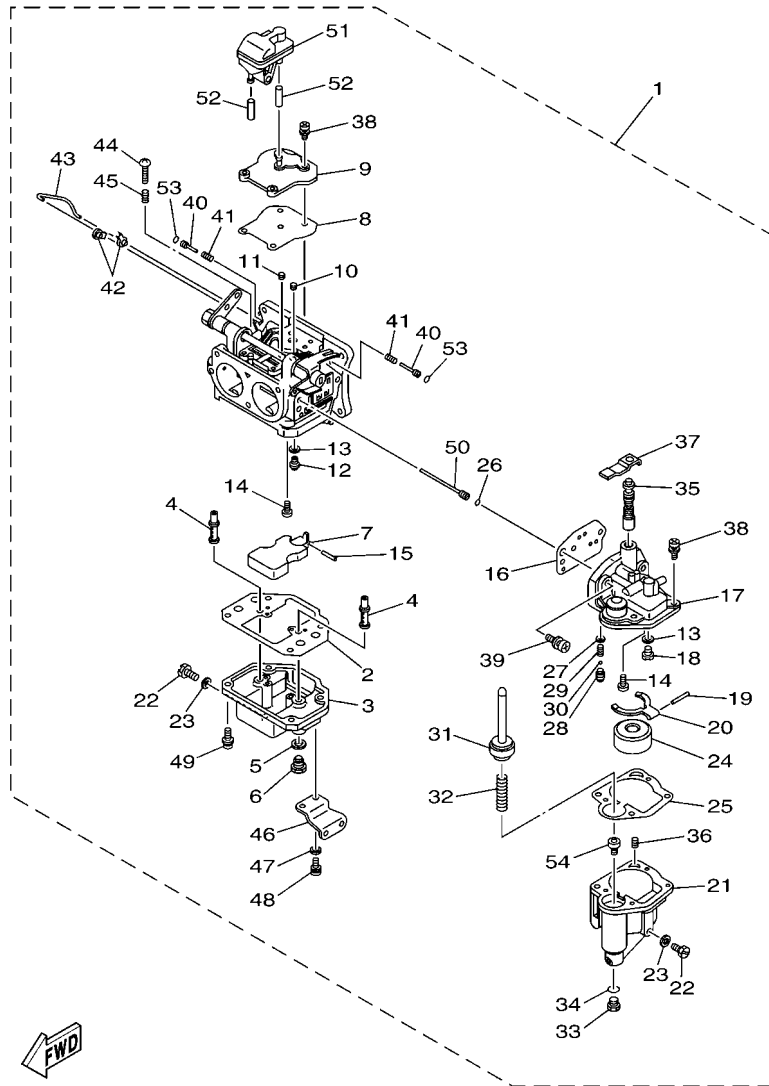

FIG. 5 INTAKE

REF. NO.	PART NO.	DESCRIPTION	6F5H				REMARKS
28	624-14485-00	PIPE, JOINT	1				
29	90445-07240	HOSE (L330)	1				
30	90467-06016	CLIP	1				
31	6F5-14483-00	GASKET	1				
32	6F5-41252-00	LEVER, CHOKE 1	1				
33	682-41271-01	KNOB, CHOKE	1				
34	689-41273-00	GROMMET	1				
35	6F5-41256-00	ROD, CHOKE 1	1				
36	661-41262-02	JOINT, CHOKE LEVER	2				
37	91690-40032	PIN, SPRING	1				
38	90445-07254	HOSE (L118)	1				
39	90445-07240	HOSE (L330)	2				
40	90445-07M24	HOSE (L240)	1				
41	90467-06016	CLIP	6				

FIG. 6 CARBURETOR



6F55200-E050

REF. NO.	PART NO.	DESCRIPTION	6F5H				REMARKS
1	6F5-14301-42	CARBURETOR ASSY 1	1				
2	6F5-14384-00	.GASKET, FLOAT CHAMBER	1				
3	6F5-14381-00	.BODY, FLOAT CHAMBER	1				
4	6F5-14341-00	.NOZZLE, MAIN	2				
5	1J2-14398-00	.GASKET	2				
6	677-14343-73	.JET, MAIN (#145)	2				
7	6F6-14385-00	.FLOAT	1				
8	6F5-14398-00	.GASKET	1				
9	6F5-14383-00	.PLATE, COVER	1				
10	647-14342-45	.JET, PILOT (# 90)	2				
11	647-14342-30	.JET, PILOT (# 60)	2				
12	6F5-14390-21	.NEEDLE VALVE ASSY	1				
13	367-14195-00	.GASKET	2				
14	98980-04006	.SCREW, BIND	2				
15	6E5-14386-01	.PIN, FLOAT	1				
16	6F5-14399-00	.GASKET	1				
17	6F5-14182-41	.COVER, FLOAT CHAMBER	1				
18	6F5-14390-12	.NEEDLE VALVE ASSY	1				
19	367-14386-00	.PIN, FLOAT	1				
20	6F5-14387-00	.ARM, FLOAT	1				
21	6F5-14381-11	.BODY, FLOAT CHAMBER	1				
22	6F5-14383-10	.SCREW, DRAIN	2				
23	6E5-14398-00	.GASKET	2				
24	626-14385-00	.FLOAT	1				
25	6F5-14384-10	.GASKET, FLOAT CHAMBER	1				
26	6F5-14397-00	.O-RING	1				
27	6F5-14372-01	.SEAT, PACKING	1				

FIG. 6 CARBURETOR

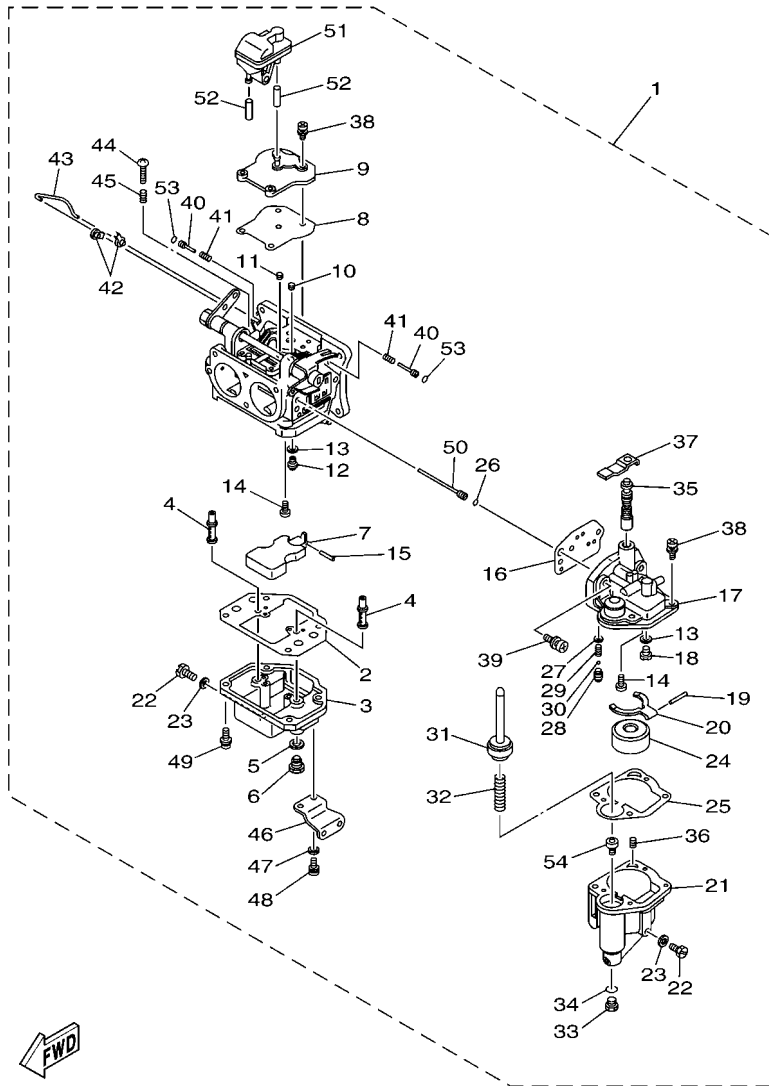

FWD
6F55200-E050

REF. NO.	PART NO.	DESCRIPTION	6F5H				REMARKS
28	6A4-14355-00	.SEAT, BALL	1				
29	6F5-14332-01	.SPRING	1				
30	6F5-14369-00	.BALL	1				
31	6F5-14370-02	.PLUNGER STARTER ASSY	1				
32	6F5-14339-00	.SPRING	1				
33	6A4-14394-00	.SCREW, DRAIN	1				
34	652-14397-00	.O-RING	1				
35	6F5-14371-00	.PLUNGER, STARTER	1				
36	647-14344-35	.JET, STARTER (# 70)	1				
37	6F5-14377-00	.STOPPER	1				
38	97603-04114	.SCREW, PAN HEAD WITH WASHER	8				
39	97603-06120	.SCREW, PAN HEAD WITH WASHER	2				
40	6F5-14323-01	.SCREW, AIR ADJUSTING	2				
41	6F5-14334-01	.SPRING, AIR ADJUSTING	2				
42	6F5-41262-01	.JOINT, THROTTLE LEVER	2				
43	6F5-14379-00	.ROD, STARTER	1				
44	650-14321-01	.SCREW, THROTTLE	1				
45	647-14334-00	.SPRING	1				
46	6F5-14346-00	.PLATE	1				
47	654-14243-00	.WASHER	4				
48	97603-06113	.SCREW, PAN HEAD WITH WASHER	4				
49	97603-05117	.SCREW, PAN HEAD WITH WASHER	4				
50	6F5-14340-00	.NOZZLE, ACCELERATING	1				
51	6F5-14425-00	.DAMPER 1	1				
52	90445-09M55	.HOSE (L20)	2				
53	5Y1-14397-00	.O-RING	2				
54	6F5-13940-01	.CHECK VALVE ASSY	1				

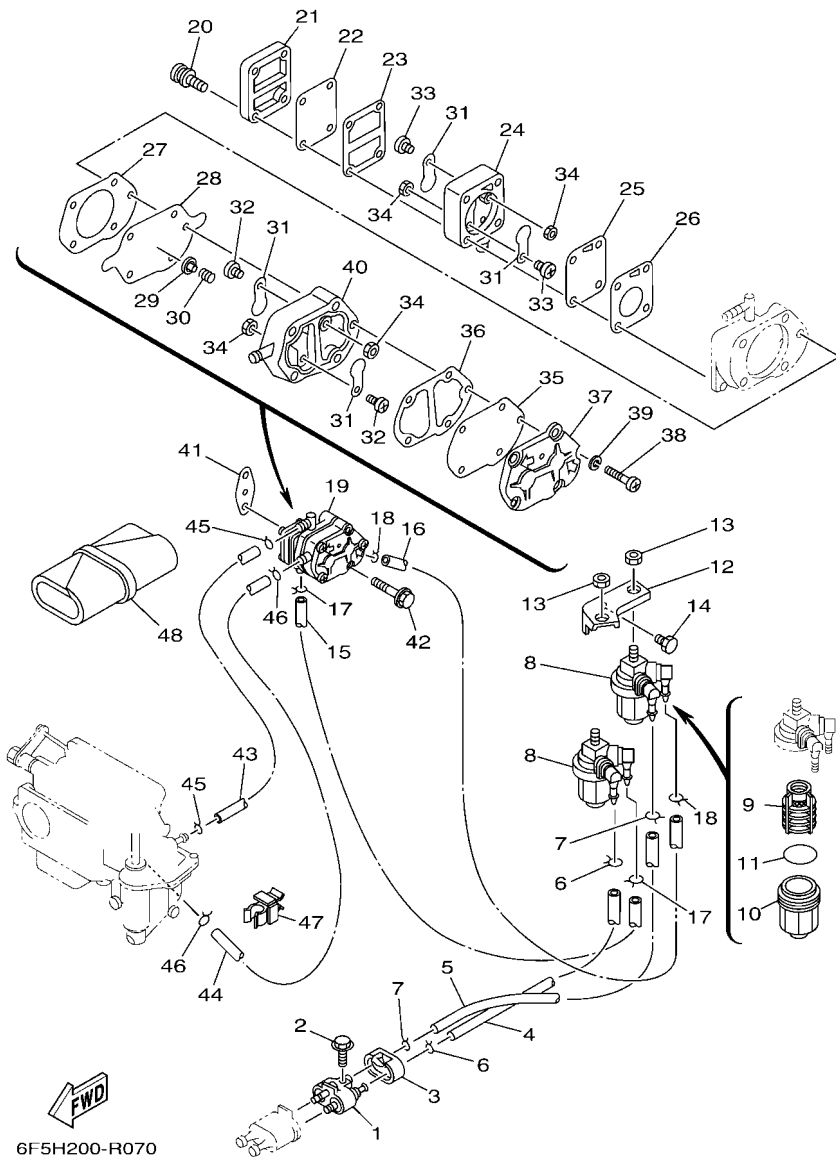

FIG. 7 FUEL 1

REF. NO.	PART NO.	DESCRIPTION	6F5H	REMARKS
1	680-24304-10	FUEL PIPE JOINT COMP. 1	1	
2	97595-06525	BOLT, WITH WASHER	1	
3	6A4-24329-00	SEAL	1	
4	90445-09226	HOSE (L390)	1	
5	90445-10M43	HOSE (L400)	1	
6	90467-08004	CLIP	2	
7	90467-09M03	CLIP	2	
8	61N-24560-00	FILTER ASSY	2	
9	61N-24563-00	.ELEMENT, FILTER	1	
10	61N-24521-00	.CUP, FILTER	1	
11	93210-32738	.O-RING	1	
12	6F5-24566-00	BRACKET, FILTER	1	
13	95380-08600	NUT	2	
14	97013-06014	BOLT	1	
15	90445-09M54	HOSE (L225)	1	
16	90445-10M50	HOSE (L170)	1	
17	90467-08004	CLIP	2	
18	90467-09M03	CLIP	2	
19	6F5-24410-06	FUEL PUMP ASSY	1	
20	677-24444-01	.SCREW	4	
21	677-24413-01	.BODY 2	1	
22	677-24471-01	.DIAPHRAGM	1	
23	677-24435-02	.GASKET, BODY 2	1	
24	682-24412-01	.BODY 1	1	
25	677-24411-02	.DIAPHRAGM	1	
26	677-24434-02	.GASKET, BODY	1	
27	648-24434-01	.GASKET, BODY	1	

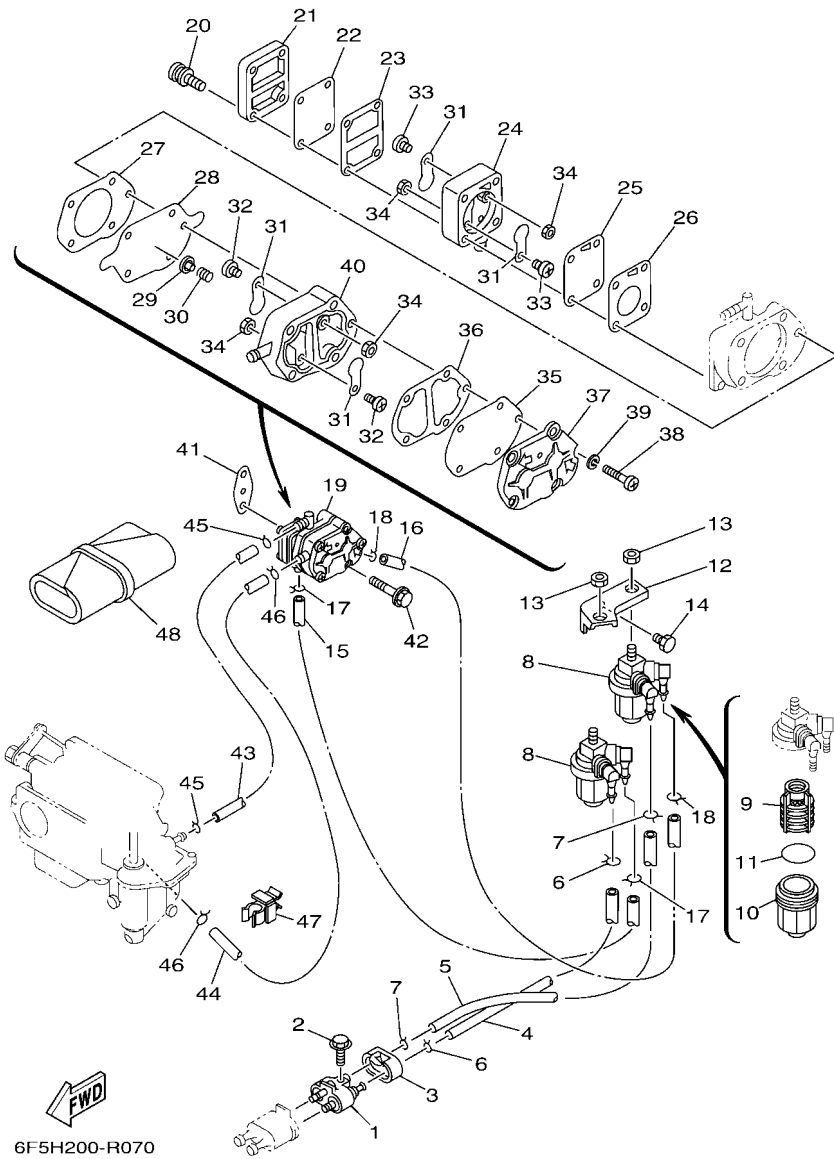
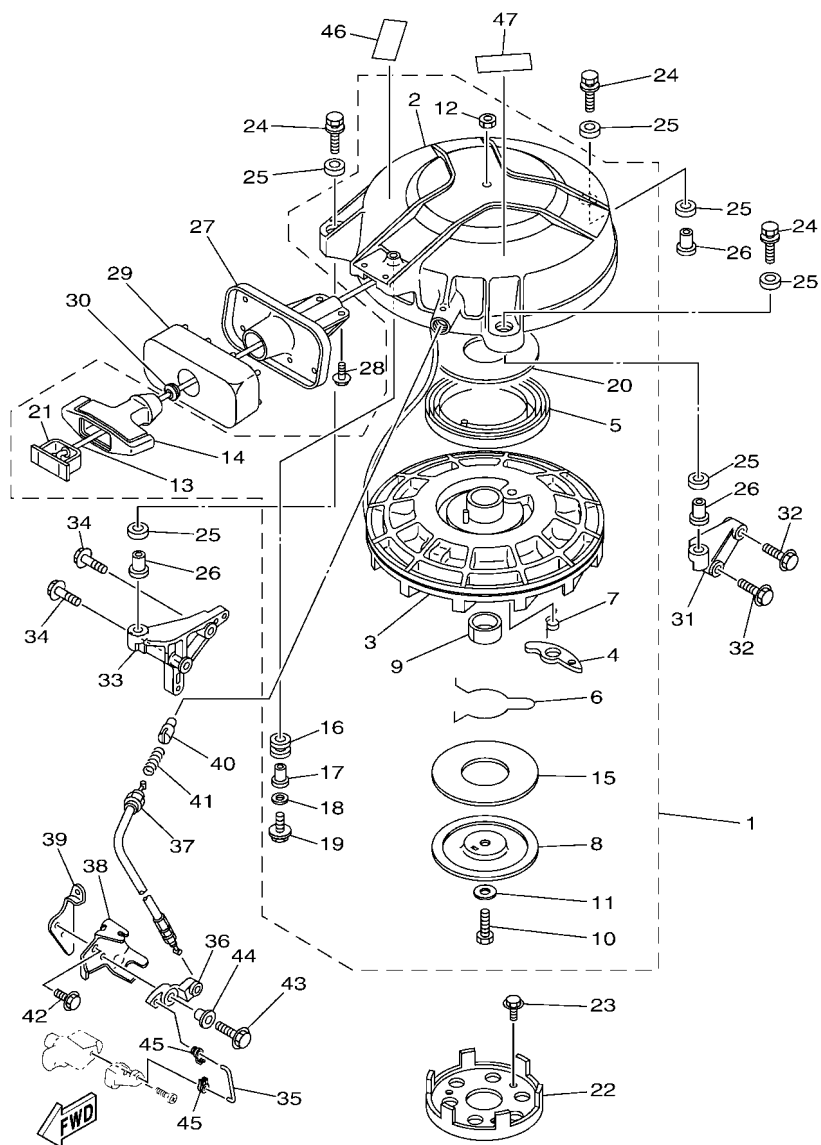

FIG. 7 FUEL 1

REF. NO.	PART NO.	DESCRIPTION	6F5H				REMARKS
28	648-24411-00	.DIAPHRAGM	1				
29	648-24424-00	.SEAT, SPRING	1				
30	648-24423-00	.SPRING, DIAPHRAGM	1				
31	6A0-24421-01	.VALVE, CHECK	4				
32	6A0-14325-00	.SCREW, PAN HEAD	2				
33	6E7-14325-00	.SCREW, PAN HEAD	2				
34	95380-03600	.NUT	4				
35	663-24411-00	.DIAPHRAGM	1				
36	648-24435-02	.GASKET, BODY 2	1				
37	6A0-24413-00	.BODY 2	1				
38	98503-05028	.SCREW, PAN HEAD	3				
39	92990-05100	.WASHER, SPRING	3				
40	6A0-24412-02	.BODY 1	1				
41	650-24431-A0	GASKET, FUEL PUMP 1	1				
42	97595-06555	BOLT, WITH WASHER	2				
43	90445-09M53	HOSE (L160)	1				
44	90445-10M50	HOSE (L170)	1				
45	90467-08004	CLIP	2				
46	90467-09M03	CLIP	2				
47	90464-07008	CLAMP	1				
48	676-W2810-01	TOOL KIT	1				



6F5H200-R090

*1: CUT FROM 50M ROLLS, PART NO.90890-44373, CUTTING LENGTH 1.9M

FIG. 9 STARTER

REF. NO.	PART NO.	DESCRIPTION	6F5H				REMARKS
1	6F5-W1571-03	STARTER ASSY	1				
2	6F5-15711-02	.CASE, STARTER	1				
3	6F5-15714-03	.DRUM, SHEAVE	1				
4	6F5-15741-01	.PAWL, DRIVE	1				
5	6F5-15713-00	.SPRING, STARTER	1				
6	6F5-15715-00	.SPRING, FRICTION	1				
7	6F5-15734-01	.SPRING, RETURN	1				
8	6F5-15716-01	.PLATE, DRIVE	1				
9	6F5-15754-00	.BUSH 2	1				
10	97013-08030	.BOLT	1				
11	6F5-15726-01	.WASHER, FLAT	1				
12	95303-08700	.NUT	1				
13	*	.WIRE (L:1900MM)	1				*1
14	689-15755-01	.HANDLE, STARTER	1				
15	6F5-15764-00	.COLLAR 1	1				
16	6F5-15752-00	.ROLLER, WIRE	1				
17	6F5-15753-00	.BUSH	1				
18	6F5-15791-00	.WASHER, LOCK	1				
19	6F5-15768-00	.BOLT	1				
20	6F5-15739-00	.WASHER, THRUST	1				
21	6F5-15779-02	.COVER	1				
22	6F5-15723-01	PULLEY, STARTER	1				
23	90105-08M10	BOLT, FLANGE	3				
24	90119-08M10	BOLT, WITH WASHER	3				
25	90385-12M04	BUSH	6				
26	90387-08M05	COLLAR	3				
27	6A0-15758-01-8D	GUIDE, ROPE	1				

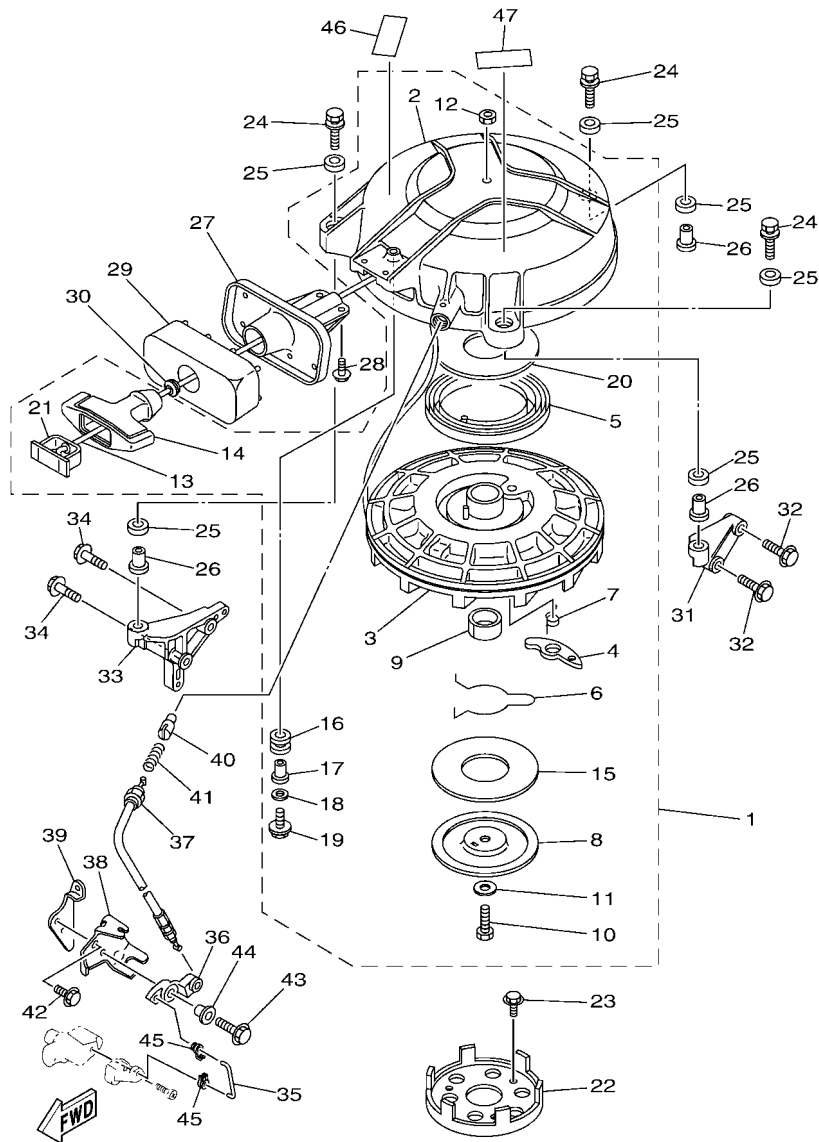

6F5H200-R090

*1: CUT FROM 50M ROLLS, PART NO.90890-44373, CUTTING LENGTH 1.9M

FIG. 9 STARTER

REF. NO.	PART NO.	DESCRIPTION	6F5H				REMARKS
28	97595-06516	BOLT, WITH WASHER	2				
29	6A0-15762-01	SEAL, RUBBER 2	1				
30	6A0-15789-00	DAMPER	1				
31	6F5-15771-00-94	STAY 1	1				
32	97513-08535	BOLT, WITH WASHER	2				
33	6F5-15772-00-94	STAY 2	1				
34	97513-08535	BOLT, WITH WASHER	2				
35	6F5-15747-00	LINK	1				
36	6F5-15746-00	ARM	1				
37	6F5-15770-00	CABLE COMP., STARTER STOP	1				
38	6F5-15774-00	STAY 4	1				
39	6F5-15773-00	STAY 3	1				
40	656-15748-00	PLUNGER, STARTER STOP	1				
41	90501-10227	SPRING, COMPRESSION	1				
42	97595-06516	BOLT, WITH WASHER	1				
43	97595-06530	BOLT, WITH WASHER	1				
44	90387-06M29	COLLAR	1				
45	661-41262-02	JOINT, CHOKE LEVER	2				
46	6EE-81994-40	LABEL, SAFETY	1				
47	6EE-81995-40	LABEL, WARNING	1				

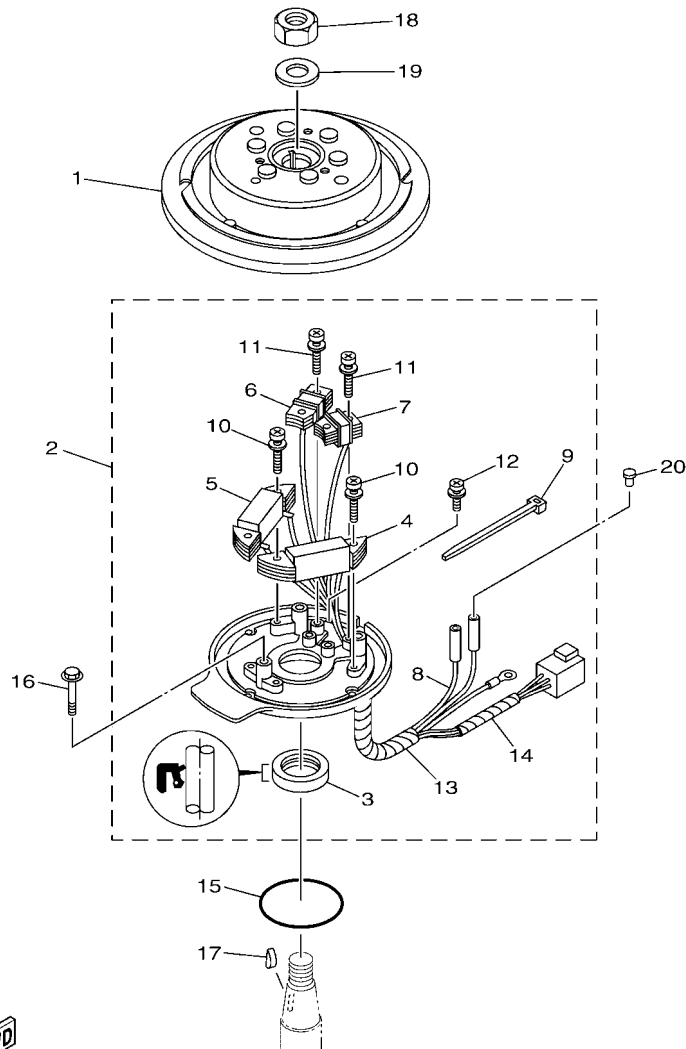

FIG. 10 GENERATOR

REF. NO.	PART NO.	DESCRIPTION	6F5H				REMARKS
1	6F5-85550-G0	ROTOR ASSY	1				
2	6F5-85560-B0	BASE ASSY	1				
3	93102-35M18	.OIL SEAL	1				
4	6F5-85520-10	.COIL, CHARGE	1				
5	6F5-85533-10	.COIL, LIGHTING	1				
6	6F5-85580-10	.COIL, PULSER	1				
7	6F5-85580-20	.COIL, PULSER	1				
8	6F5-85515-10	.LEAD WIRE ASSY	1				
9	6F5-81328-00	.CLAMP	1				
10	90159-05040	.SCREW, WITH WASHER	4				
11	90159-04063	.SCREW, WITH WASHER	4				
12	90159-04035	.SCREW, WITH WASHER	1				
13	6F5-85597-J0	.TUBE 1	1				
14	6F5-85597-H0	.TUBE 1	1				
15	93210-75M51	O-RING	1				
16	97595-06540	BOLT, WITH WASHER	3				
17	90280-05015	KEY, WOODRUFF	1				
18	90170-20137	NUT	1				
19	90201-21M18	WASHER, PLATE	1				
20	703-82119-00	COVER, LEAD WIRE	2				

6F5H200-R100

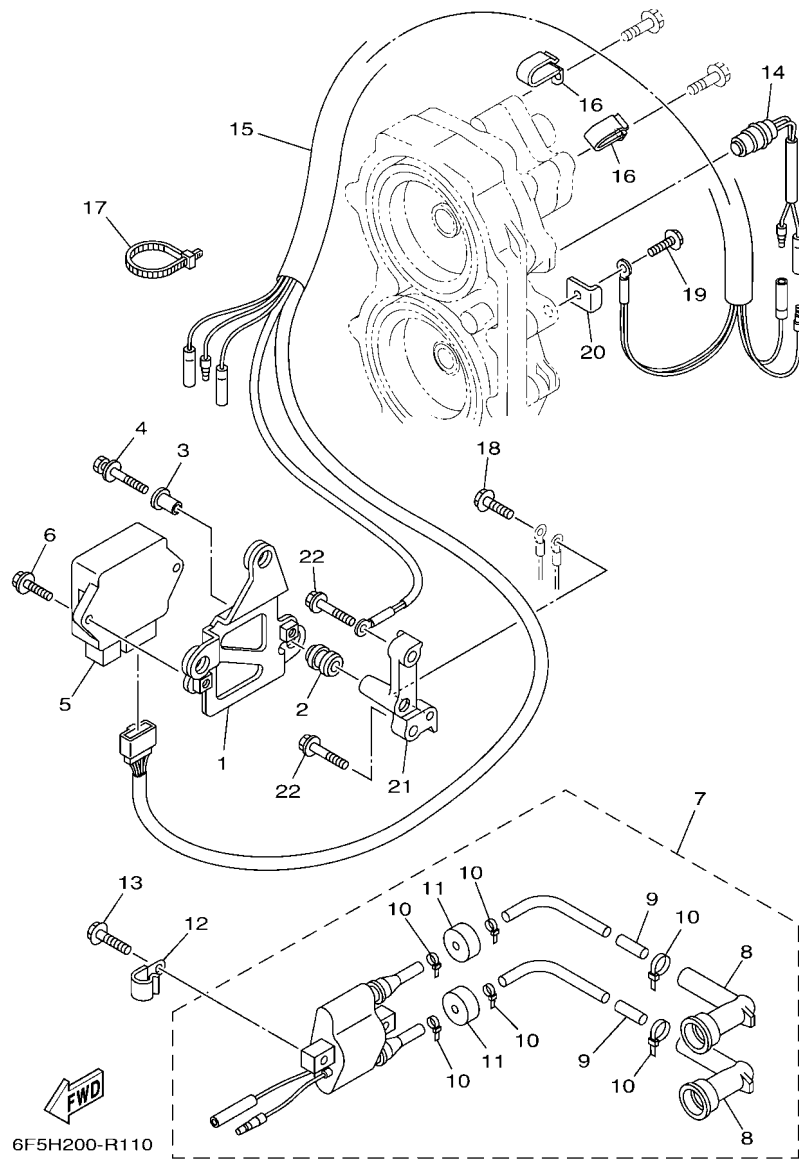
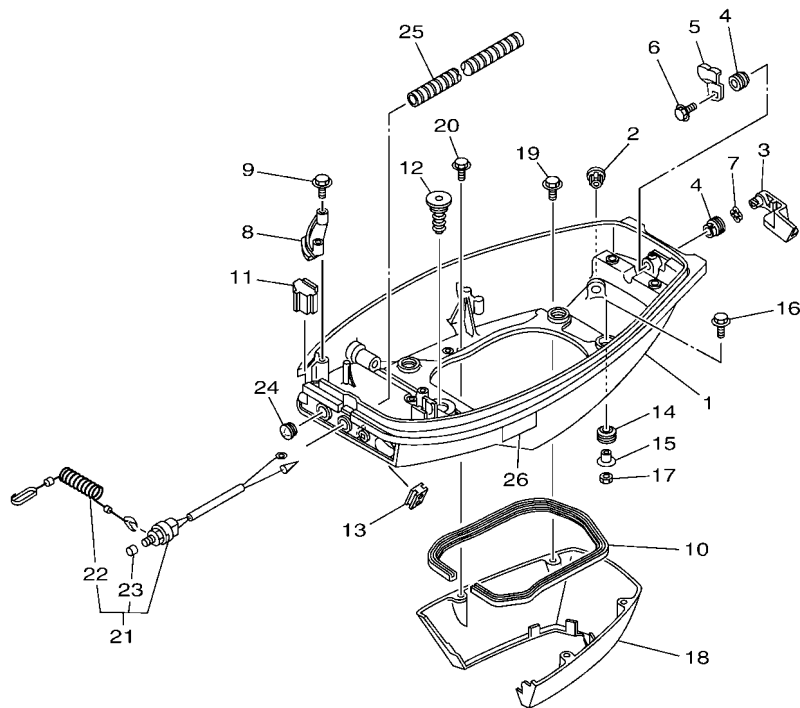

FIG. 11 ELECTRICAL

REF. NO.	PART NO.	DESCRIPTION	6F5H				REMARKS
1	6F5-85542-10	BRACKET	1				
2	61N-82317-00	DAMPER, IGNITION COIL	3				
3	90387-06119	COLLAR	3				
4	90119-06M65	BOLT, WITH WASHER	3				
5	6F5-85540-32	C.D.I. UNIT ASSY	1				
6	90109-06M86	BOLT	2				
7	6F6-85530-01	IGNITION COIL ASSY	1				
8	62E-82371-11	.CAP, PLUG	2				
9	62E-8231X-00	.TERMINAL 1	2				
10	90465-11M10	.CLAMP	6				
11	90480-25161	.GROMMET	2				
12	90465-08M07	CLAMP	1				
13	97595-06525	BOLT, WITH WASHER	2				
14	688-82560-10	THERMO SWITCH ASSY	1				
15	6F5-82580-00	WIRE HARNESS ASSY 2	1				
16	90462-08096	CLAMP	2				
17	90465-13M18	CLAMP	2				
18	97595-06516	BOLT, WITH WASHER	1				
19	97595-06516	BOLT, WITH WASHER	1				
20	6F5-82588-00	PLATE	1				
21	6F5-81948-A0	BRACKET	1				
22	90105-08M35	BOLT, FLANGE	2				

FIG. 12 BOTTOM COWLING



6F5H200-R120

REF. NO.	PART NO.	DESCRIPTION	6F5H				REMARKS
1	6F5-42711-03-8D	COWLING, BOTTOM 1	1				
2	6E5-44391-00	NIPPLE, HOSE	1				
3	6F5-42815-01-8D	LEVER, CLAMP 1	1				
4	90386-12M37	BUSH	2				
5	6F5-42816-00	LEVER, CLAMP 2	1				
6	90119-06M73	BOLT, WITH WASHER	1				
7	90206-12052	WASHER, WAVE	1				
8	6F5-42738-01-94	PLATE, FITTING	1				
9	97513-06525	BOLT, WITH WASHER	2				
10	6F5-42716-00	RUBBER SEAL 1	1				
11	6F5-42724-00	GROMMET	1				
12	6F5-42727-00	GROMMET	1				
13	676-26326-00	GROMMET	1				
14	90480-09M21	GROMMET	4				
15	90387-06M41	COLLAR	4				
16	90119-06M61	BOLT, WITH WASHER	4				
17	95380-06600	NUT, HEXAGON	4				
18	6F5-42741-11	APRON	1				
19	97595-06525	BOLT, WITH WASHER	2				
20	90119-06M11	BOLT, WITH WASHER	2				
21	6E9-82575-02	ENGINE STOP SWITCH ASSY	1				
22	682-82556-00	.LANYARD, STOP SWITCH	1				
23	689-8257Y-00	.CAP	1				
24	676-42726-00	GROMMET	1				
25	90447-13011	TUBE	1				
26	6EE-42794-40	LABEL, WARNING (GENERAL)	1				

1
**HANDLE STEERING
 ASSY**
 Fig. 13, STEERING
 Ref. No. 2 to 29

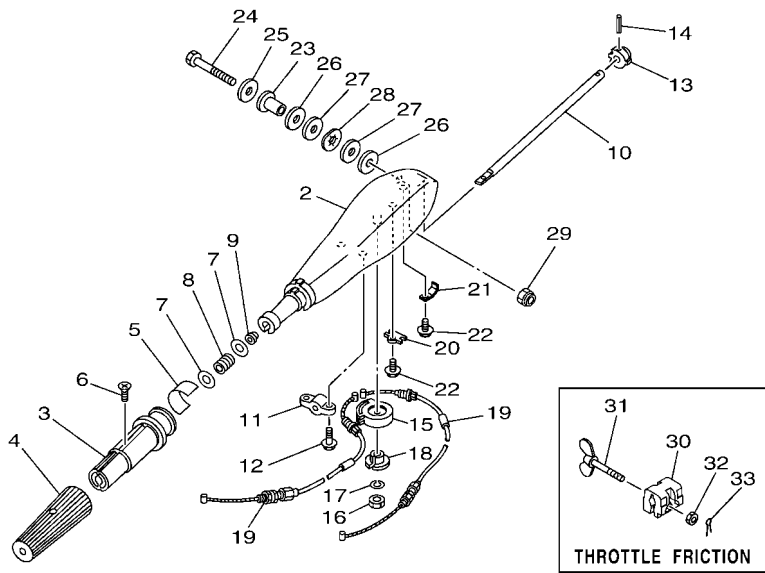
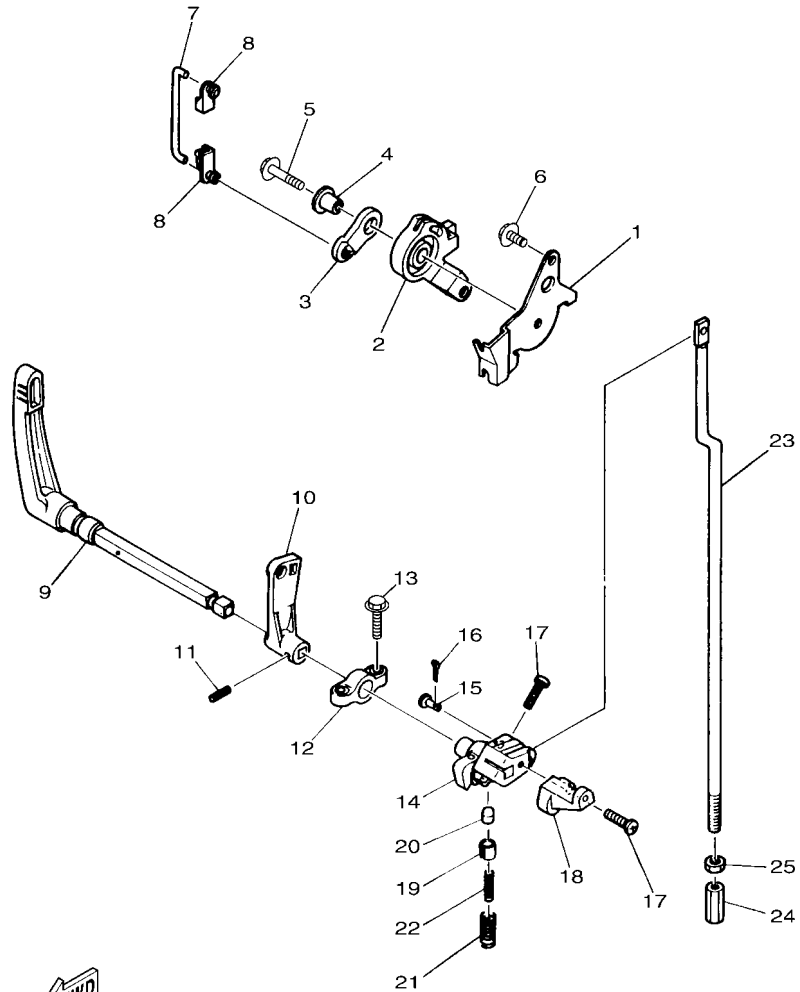

FIG. 13 STEERING

REF. NO.	PART NO.	DESCRIPTION	6F5H				REMARKS
1	6F5-W0084-02-8D	HANDLE STEERING ASSY	1				
2	676-42111-03-8D	HANDLE, STEERING	1				
3	664-42119-00	GRIP, STEERING HANDLE	1				
4	6G1-42177-00	RUBBER, HANDLE	1				
5	6F5-42137-20	INDICATOR, THROTTLE	1				
6	90152-05011	SCREW, COUNTERSUNK	1				
7	90201-10M02	WASHER, PLATE	2				
8	90501-23215	SPRING, COMPRESSION	1				
9	90386-08032	BUSH	1				
10	676-42115-00	SHAFT, STEERING HANDLE	1				
11	676-42159-00	STAY	1				
12	97595-06520	BOLT, WITH WASHER	2				
13	650-42152-00-94	GEAR	1				
14	91690-30025	PIN, SPRING	1				
15	676-42151-00-94	PINION	1				
16	95380-06600	NUT, HEXAGON	1				
17	92990-06100	WASHER, SPRING	1				
18	90386-08M00	BUSH	1				
19	6F5-26311-00	CABLE, THROTTLE 1	2				
20	676-26391-00	CLIP, CABLE	1				
21	676-26392-00	CLIP, CABLE 2	1				
22	97595-05510	BOLT HEX. HEAD	2				
23	90386-12089	BUSH	1				
24	90101-12M37	BOLT	1				
25	92990-12200	WASHER, PLAIN	1				
26	90202-12092	WASHER, PLATE	2				
27	90201-12537	WASHER, PLATE	2				

FWD
 6F5H200-R130

FIG. 14 CONTROL



6F5H200-R140

REF. NO.	PART NO.	DESCRIPTION	6F5H				REMARKS
1	6F5-14497-00	STAY, THROTTLE WIRE	1				
2	6F5-41638-00	PULLEY	1				
3	6F5-41283-00	LEVER, FREE ACCEL.	1				
4	90387-06M29	COLLAR	1				
5	97595-06530	BOLT, WITH WASHER	1				
6	97595-06516	BOLT, WITH WASHER	1				
7	6F5-41211-00	LINK, ACCEL.	1				
8	6E9-41237-00	JOINT, LINK	2				
9	6F5-44111-01	HANDLE, GEAR SHIFT	1				
10	6F5-44125-00	LEVER, SHIFT ROD	1				
11	91690-25016	PIN, SPRING	1				
12	6F5-41662-00	BRACKET 2	1				
13	97513-06525	BOLT, WITH WASHER	2				
14	6F5-44121-00	LEVER, SHIFT ROD	1				
15	90240-05M09	PIN, CLEVIS	1				
16	91490-16010	PIN, COTTER	1				
17	97780-40520	SCREW, TAPPING	2				
18	6F5-44173-00	LEVER, SHIFT CONTROL	1				
19	6F5-42715-00	BUSHING	1				
20	6F5-44167-00	PLUNGER, SHIFT CAM	1				
21	90501-12M36	SPRING, COMPRESSION	1				
22	90501-07M33	SPRING, COMPRESSION	1				
23	676-44143-00	ROD, SHIFT 1	1				
24	648-44146-00	CONNECTOR, SHIFT ROD 2	1				
25	90170-07021	NUT	1				

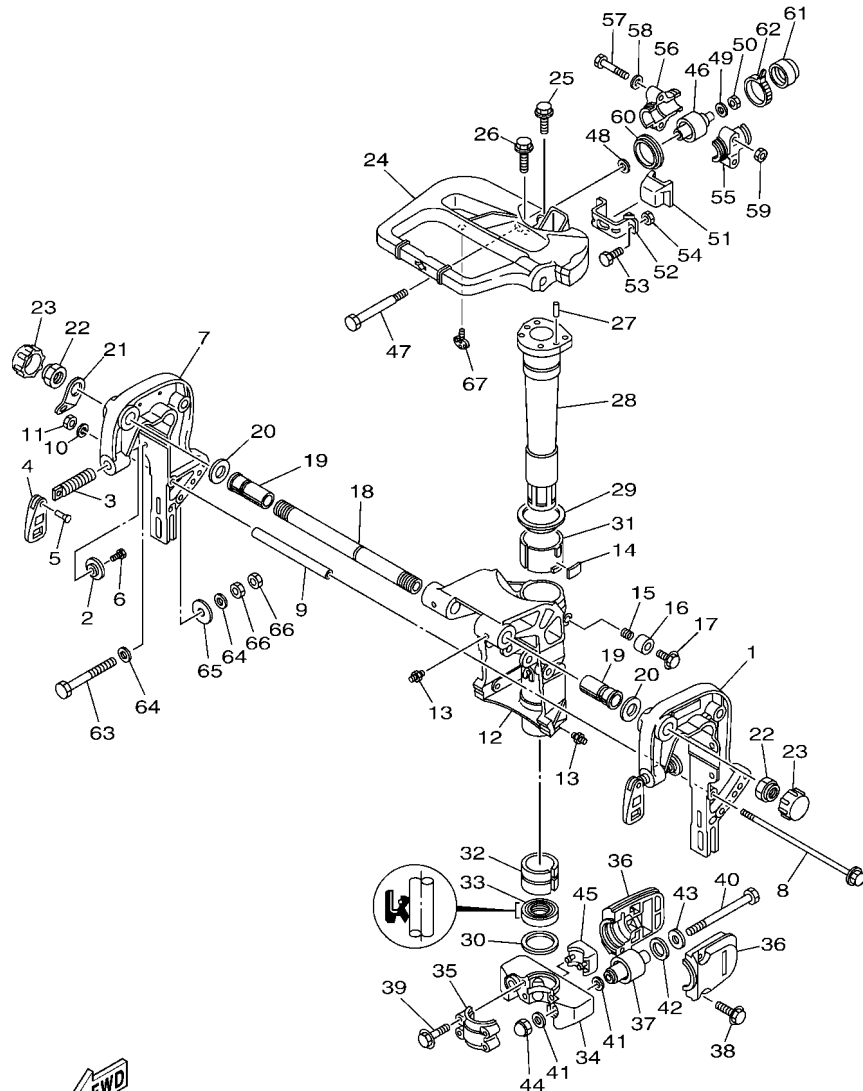

6F5H200-R150

FIG. 15 BRACKET 1

REF. NO.	PART NO.	DESCRIPTION	6F5H			REMARKS
1	676-43111-04-8D	BRACKET, CLAMP 1	1			
2	6F5-43114-00	PAD, TRANSOM CLAMP	2			
3	6F5-43116-00	SCREW, TRANSOM CLAMP	2			
4	663-43118-01-8D	HANDLE, TRANSOM CLAMP	2			
5	90243-04007	PIN	2			
6	90109-06M12	BOLT	2			
7	676-43112-04-8D	BRACKET, CLAMP 2	1			
8	90105-08117	BOLT, FLANGE	1			
9	90387-08M02	COLLAR	1			
10	92990-08100	WASHER, SPRING	1			
11	95380-08600	NUT	1			
12	676-43311-11-8D	BRACKET, SWIVEL 1	1			
13	93700-06M03	NIPPLE, GREASE	4			
14	648-42528-00	PLATE, FRICTION	1			
15	90501-18M00	SPRING, COMPRESSION	1			
16	676-43373-00	SEAL, DAMPER	1			
17	97575-08525	BOLT, WITH WASHER	1			
18	6J8-43131-01	BOLT, CLAMP BRACKET	1			
19	90386-22M15	BUSH	2			
20	90201-22M03	WASHER, PLATE	2			
21	6J8-43113-01	PLATE, CLAMP BRACKET	1			
22	90185-22043	NUT, SELF-LOCKING	2			
23	6G5-43145-01	CAP, CLAMP BRACKET	2			
24	676-42511-03-8D	BRACKET, STEERING	1			
25	97575-08530	BOLT, WITH WASHER	2			
26	97575-08535	BOLT, WITH WASHER	2			
27	93608-12063	PIN, DOWEL	2			

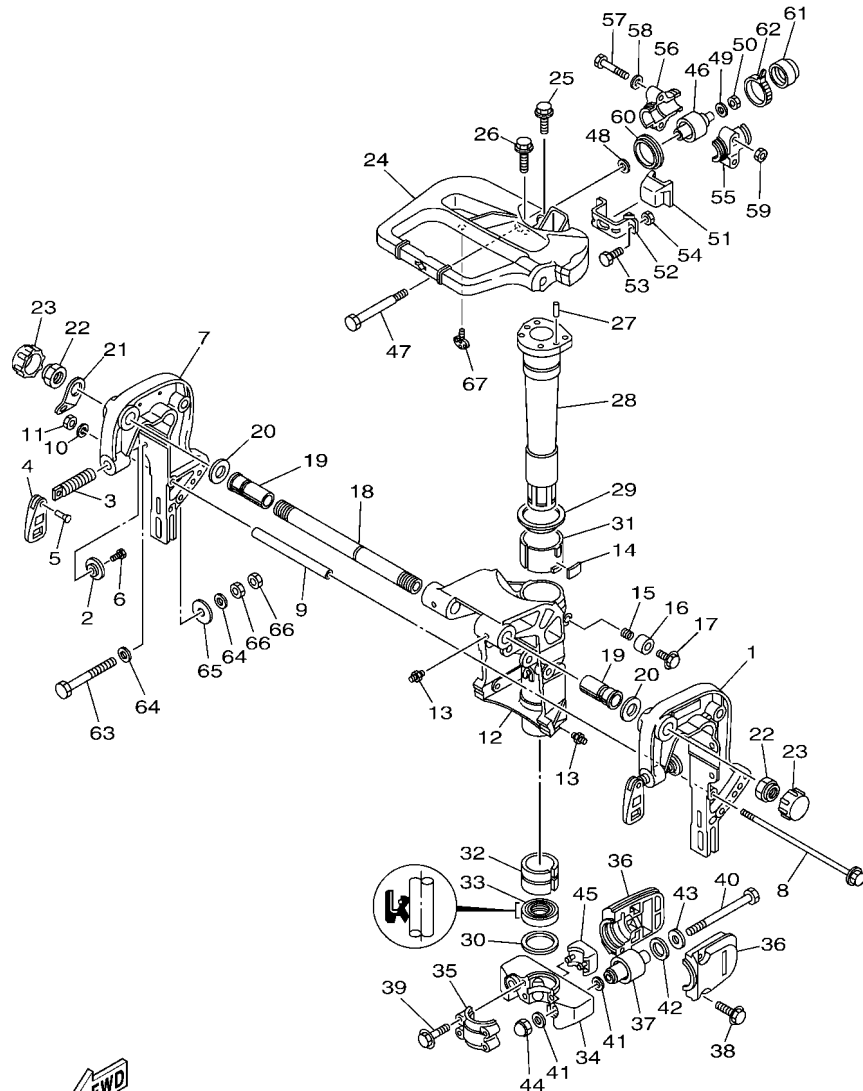

6F5H200-R150

FIG. 15 BRACKET 1

REF. NO.	PART NO.	DESCRIPTION	6F5H				REMARKS
28	676-42521-00	SHAFT, STEERING PIVOT	1				
29	90209-52M00	WASHER	1				
30	90201-44M01	WASHER, PLATE	1				
31	90386-52M02	BUSH	1				
32	90386-44M03	BUSH	1				
33	93109-44M00	OIL SEAL	1				
34	676-44551-01-8D	HOUSING, LOWER MOUNT RUBBER 1	1				
35	676-44552-01-8D	HOUSING, LOWER MOUNT RUBBER 2	1				
36	676-44553-01-8D	COVER, LOWER MOUNT	2				
37	62Y-44555-00	MOUNT DAMPER, LOWER SIDE	2				
38	97575-08530	BOLT, WITH WASHER	4				
39	97595-08545	BOLT, WITH WASHER	4				
40	90101-12M01	BOLT	2				
41	90201-12M16	WASHER, PLATE	4				
42	90202-21100	WASHER, PLATE	2				
43	90201-13M11	WASHER, PLATE	2				
44	95380-12800	NUT, CROWN	2				
45	676-44575-00	DAMPER, LOWER MOUNT RUBBER	1				
46	679-44514-00	MOUNT DAMPER, UPPER SIDE	2				
47	90101-08M02	BOLT	2				
48	90201-08M08	WASHER, PLATE	2				
49	90201-09M00	WASHER, PLATE	2				
50	90185-08057	NUT, SELF-LOCKING	2				
51	676-44533-00	DAMPER, UPPER MOUNT RUBBER	1				
52	676-44518-00	BRACKET COMP.	1				
53	97095-06025	BOLT	2				
54	95380-06600	NUT, HEXAGON	2				

FIG. 15 BRACKET 1

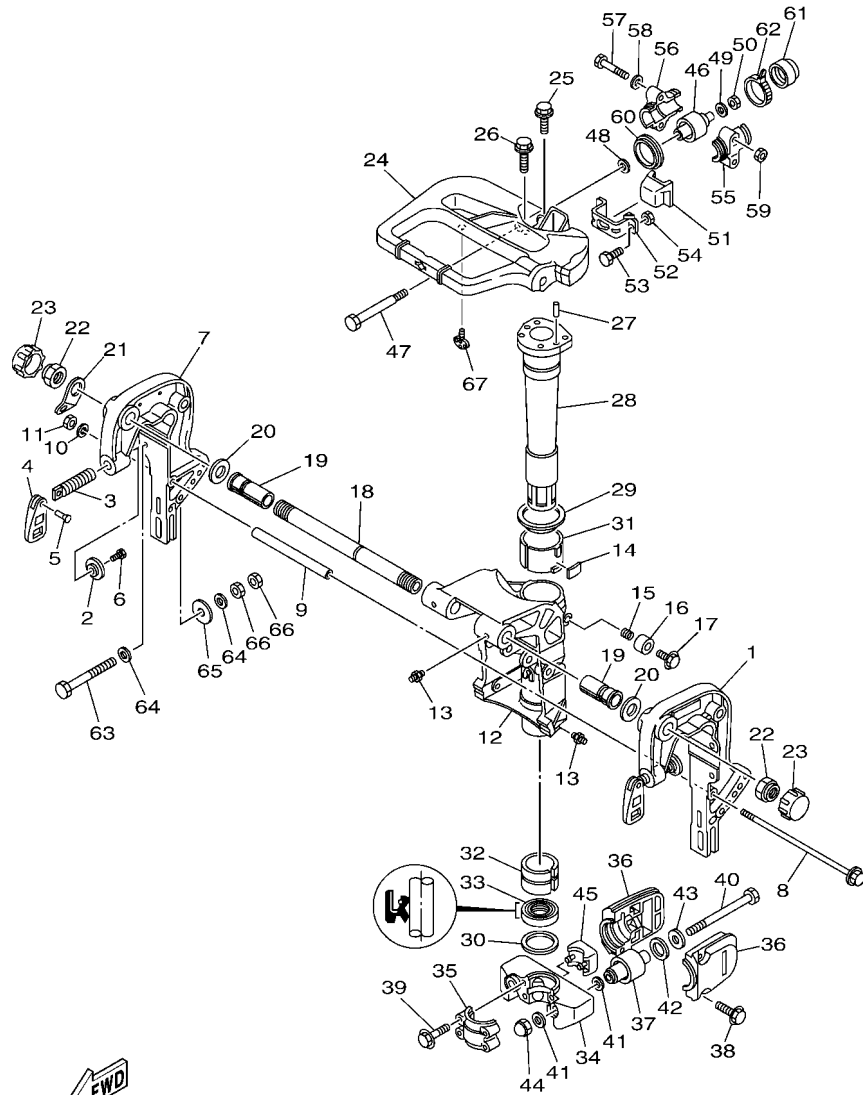

6F5H200-R150

REF. NO.	PART NO.	DESCRIPTION	6F5H				REMARKS
55	676-44511-00	COVER, UPPER MOUNT	2				
56	676-44512-00	COVER, UPPER MOUNT	2				
57	97095-08050	BOLT	4				
58	92995-08600	WASHER	4				
59	95380-08600	NUT	4				
60	676-44521-00	SEAL	2				
61	676-44522-01	SEAL	2				
62	90465-11M52	CLAMP	2				
63	90101-10M58	BOLT	4				
64	92995-10600	WASHER	8				
65	90201-12426	WASHER, PLATE	4				
66	95380-10600	NUT	8				
67	676-42591-00	HOLDER, SHEAR PIN	1				

FIG. 16 BRACKET 2

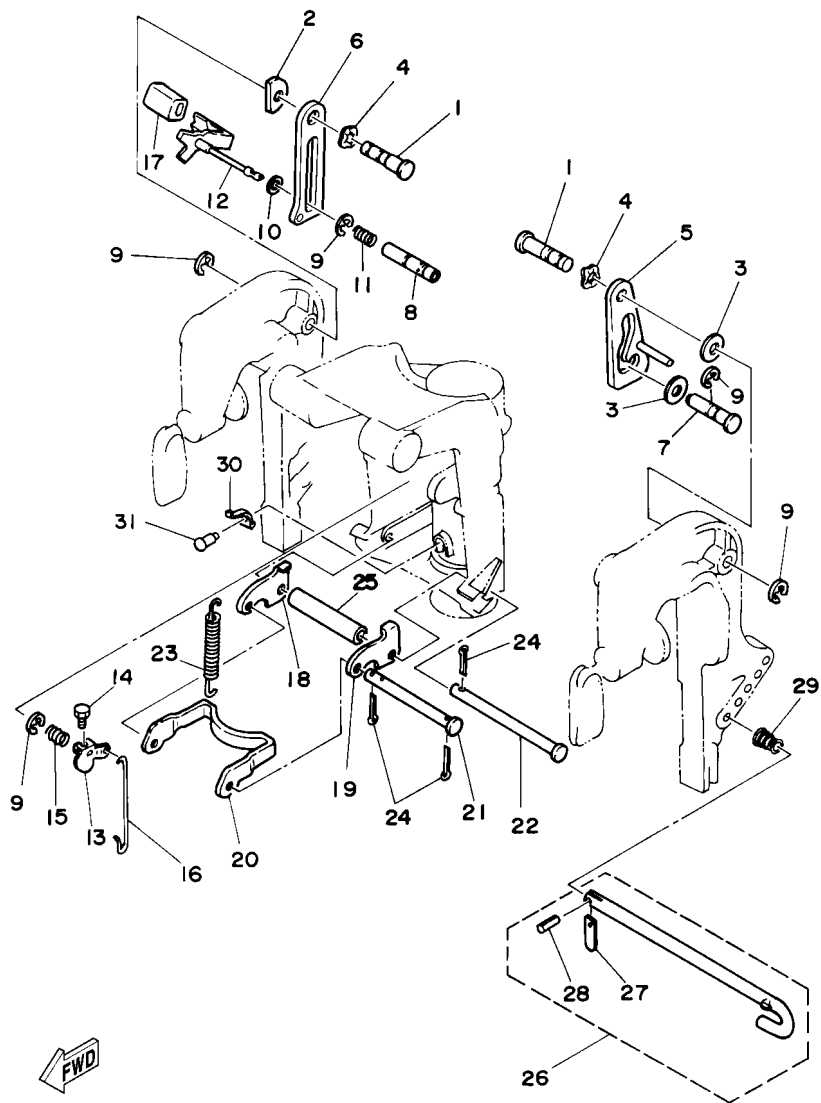

6J40200-4180

REF. NO.	PART NO.	DESCRIPTION	6F5H				REMARKS
1	90249-12M27	PIN	2				
2	676-43132-00	WASHER, FRICTION	1				
3	90202-12M01	WASHER, PLATE	2				
4	90206-12M00	WASHER, WAVE	2				
5	6F5-43627-80	STOPPER	1				
6	6F5-43628-80	STOPPER	1				
7	90249-12M13	PIN	1				
8	676-43191-00	SHAFT, STOPPER	1				
9	99080-10600	CIRCLIP	5				
10	90202-06M00	WASHER, PLATE	1				
11	90501-14M05	SPRING, COMPRESSION	1				
12	6F5-43630-80	TILT LEVER ASSY	1				
13	676-43631-00	LEVER, TILT	1				
14	97095-05010	BOLT	1				
15	90508-14M00	SPRING, TORSION	1				
16	676-43616-00	ROD, TILT LOCK	1				
17	663-43318-00	COVER	1				
18	676-43614-00	PLATE, TILT LOCK	1				
19	676-43615-00	PLATE, TILT LOCK	1				
20	676-43613-00	ARM, TILT LOCK	1				
21	90249-07M01	PIN	1				
22	90249-07M02	PIN	1				
23	90506-30M00	SPRING, TENSION	2				
24	91490-20012	PIN, COTTER	4				
25	90387-07M04	COLLAR	1				
26	676-43160-02	TILT ROD ASSY	1				
27	676-43165-00	.PLATE, TILT LOCK	1				

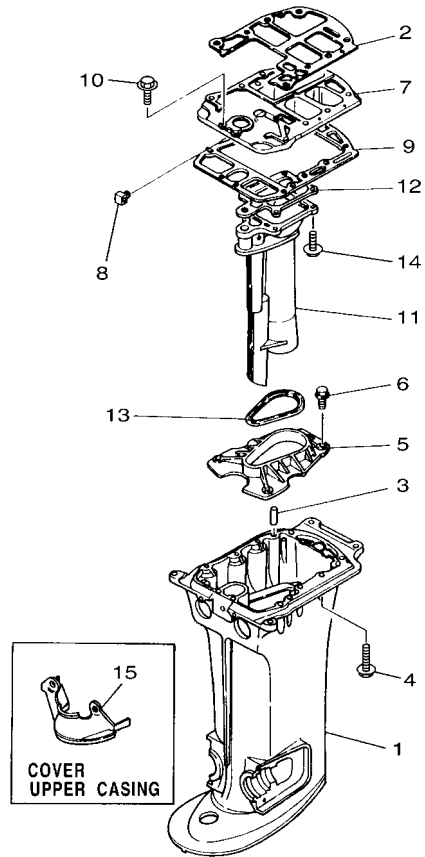

FIG. 17 UPPER CASING

REF. NO.	PART NO.	DESCRIPTION	6F5H			REMARKS
1	676-45111-15-8D	CASING, UPPER	1			L(22.5")
2	6F5-45113-A1	GASKET, UPPER CASING	1			
3	93606-25M00	PIN, DOWEL	2			
4	97595-08540	BOLT, WITH WASHER	8			
5	6F5-41116-00-CA	PROTECTOR	1			
6	90105-06M01	BOLT, FLANGE	4			
7	6F5-41137-03-CA	GUIDE, EXHAUST	1			
8	6F5-41141-00	ELBOW, WATER MIXING	1			
9	676-45114-A1	GASKET, UPPER CASING	1			
10	97595-06525	BOLT, WITH WASHER	3			
11	676-41131-01-CA	MANIFOLD, EXT. 1	1			
12	676-41133-A1	GASKET, EXHAUST MANIFOLD 1	1			
13	676-45127-00	SEAL	1			
14	97595-06520	BOLT, WITH WASHER	4			
15	676-45151-10-8D	COVER, UPPER CASING	1			L(22.5")

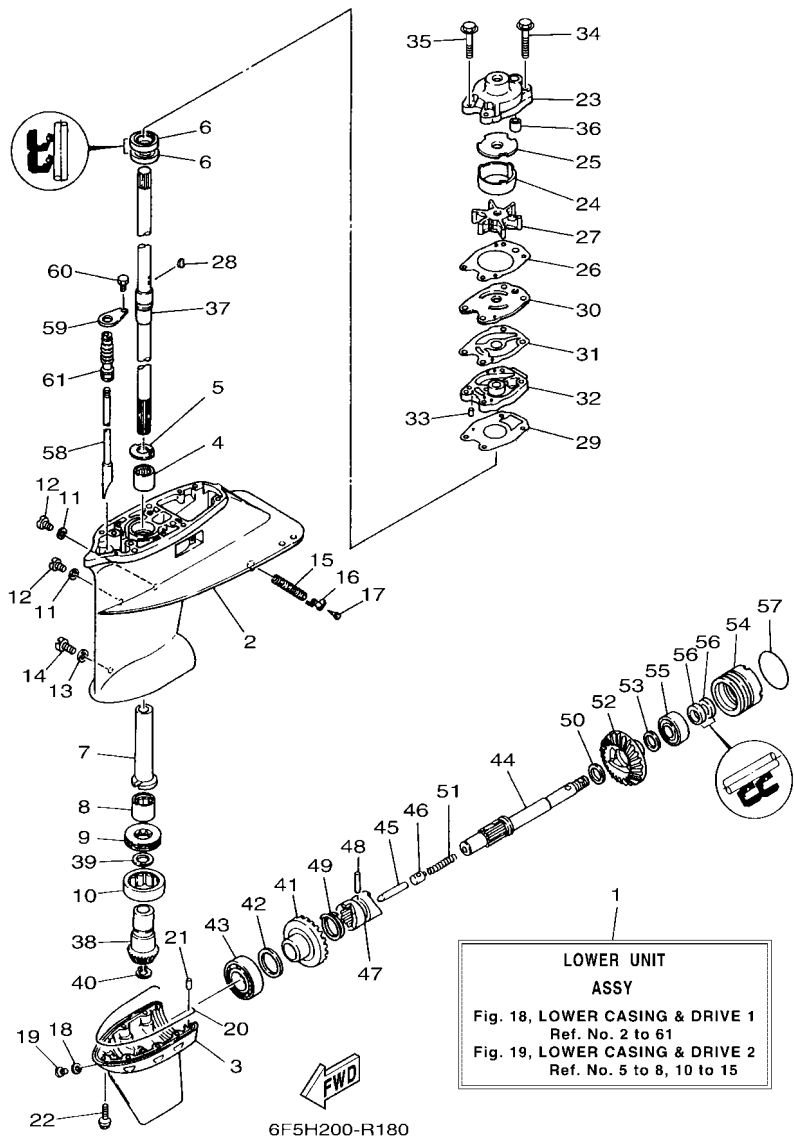

FIG. 18 LOWER CASING & DRIVE 1

REF. NO.	PART NO.	DESCRIPTION	6F5H		REMARKS
1	6F5-45300-12-8D	LOWER UNIT ASSY	1		L(22.5")
2	6F5-45311-02-8D	CASING, LOWER	1		
3	6F5-45312-01-8D	CASING, LOWER	1		
4	93315-217U0	BEARING	1		
5	676-45533-00	SHIM	1		
6	93101-22M00	OIL SEAL	2		
7	676-45536-00	SLEEVE, DRIVE SHAFT	1		
8	93315-324U1	BEARING	1		
9	93342-624U0	BEARING	1		
10	93390-000U0	BEARING	1		
11	90430-08003	GASKET	2		
12	90340-08002	PLUG, STRAIGHT SCREW	2		
13	90430-06M03	GASKET	1		
14	90149-06M00	SCREW	1		
15	676-45215-01	COVER, WATER INLET 2	1		
16	6F5-45279-01	CAP	1		
17	97780-60525	SCREW, TAPPING	1		
18	90430-08003	GASKET	1		
19	688-45341-10	PLUG, DRAIN	1		
20	676-45314-00	SEAL, LOWER CASING	1		
21	93604-09068	PIN, DOWEL	1		
22	90105-06M01	BOLT, FLANGE	9		
23	676-44311-00	HOUSING, WATER PUMP	1		
24	676-44322-40	INSERT, CARTRIDGE	1		FOR CHROMATE
25	676-44321-40	INNER PLATE, CARTRIDGE	1		FOR CHROMATE
26	676-44315-A1	GASKET, WATER PUMP	1		
27	6F5-44352-00	IMPELLER	1		

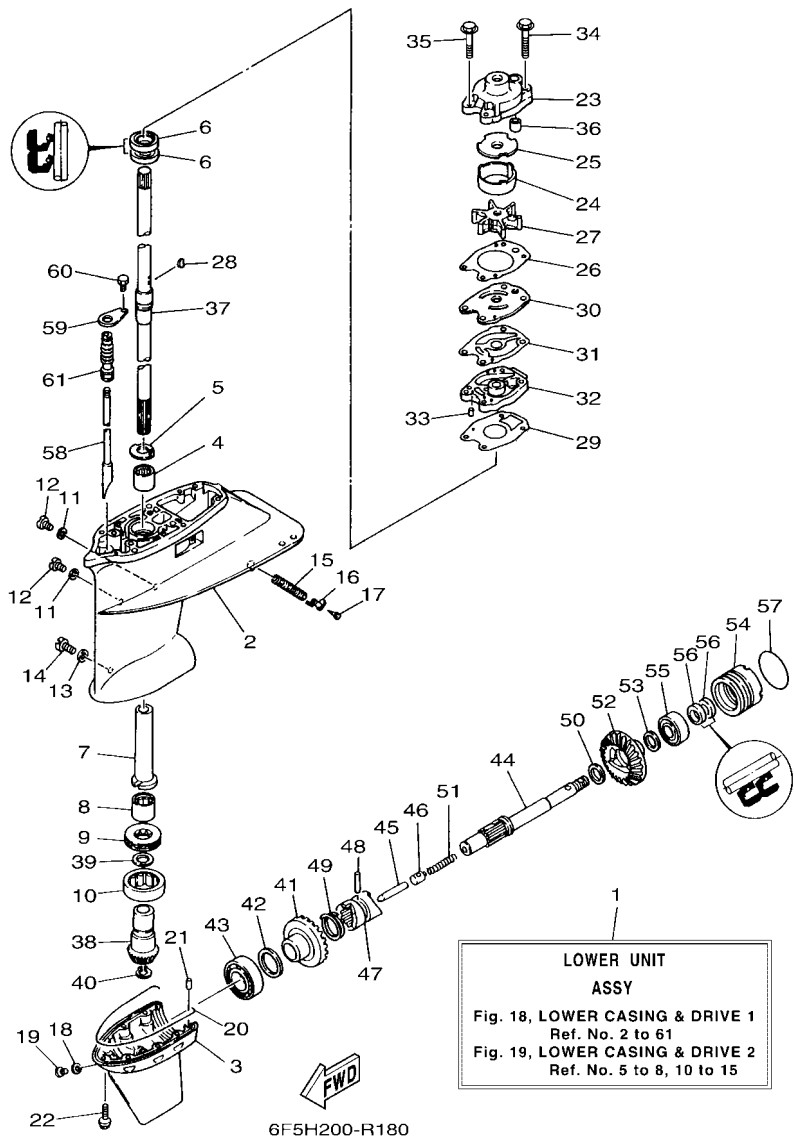

FIG. 18 LOWER CASING & DRIVE 1

REF. NO.	PART NO.	DESCRIPTION	6F5H	REMARKS
28	90280-04M00	KEY, WOODRUFF	1	
29	676-44316-A1	GASKET, WATER PUMP	1	
30	676-44323-40	OUTER PLATE, CARTRIDGE	1	FOR CHROMATE
31	676-44324-A1	GASKET, CARTRIDGE	1	
32	676-44341-01	HOUSING, WATER PUMP	1	
33	93604-08062	PIN, DOWEL	3	
34	97595-08555	BOLT, WITH WASHER	2	
35	97595-08545	BOLT, WITH WASHER	2	
36	663-44366-00	DAMPER, WATER SEAL 2	1	
37	676-45501-10	DRIVE SHAFT COMP.	1	L(22.5")
38	6F5-45551-01	PINION (13T)	1	
39	676-45587-00	SHIM (T:0.70MM)	1	UR
	676-45587-10	SHIM (T:0.75MM)	1	UR
	676-45587-20	SHIM (T:0.80MM)	1	UR
	676-45587-30	SHIM (T:0.85MM)	1	UR
40	93410-16007	CIRCLIP	1	
41	6F5-45560-01	GEAR 1 (24T)	1	
42	676-45567-00	SHIM (T:0.7MM)	1	UR
	676-45567-10	SHIM (T:0.8MM)	1	UR
	676-45567-20	SHIM (T:0.9MM)	1	UR
	676-45567-30	SHIM (T:1.0MM)	1	UR
	676-45567-40	SHIM (T:1.1MM)	1	UR
	676-45567-50	SHIM (T:1.2MM)	1	UR
43	93332-000U0	BEARING	1	
44	6F5-45611-01	SHAFT, PROPELLER	1	
45	676-45635-00	PLUNGER, SHIFT	1	
46	663-45634-00	SLIDE, SHIFT	1	

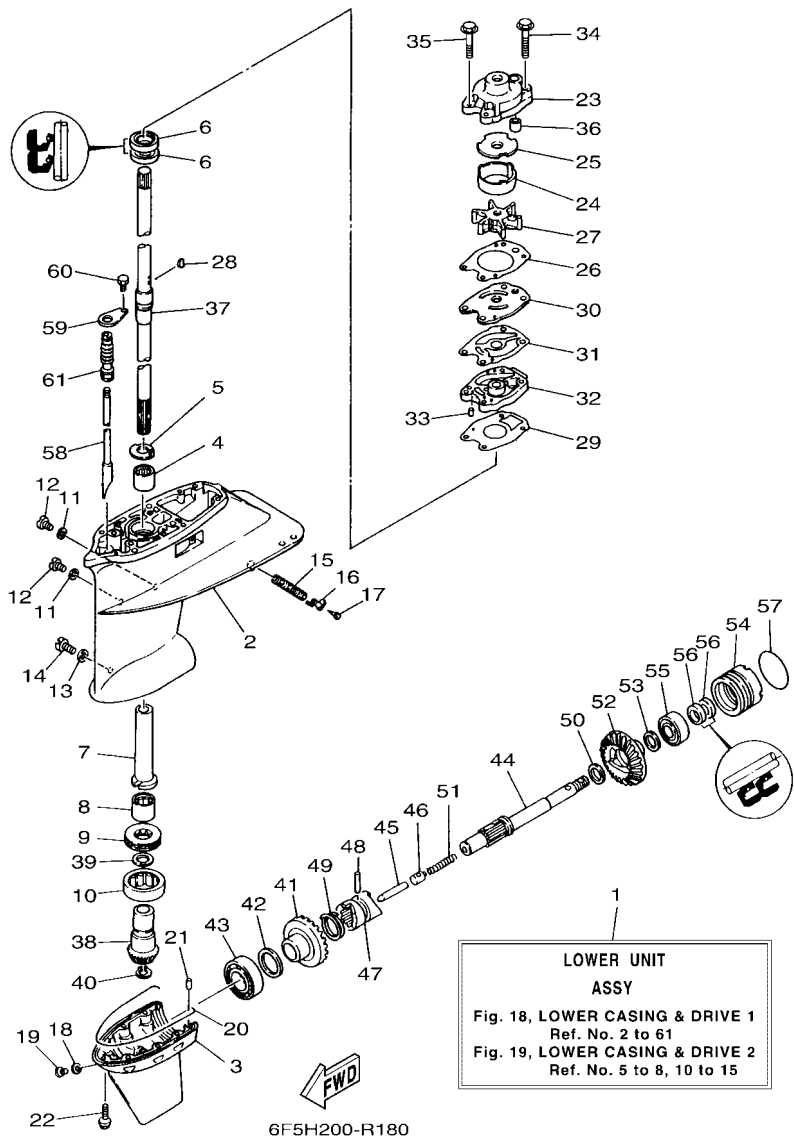
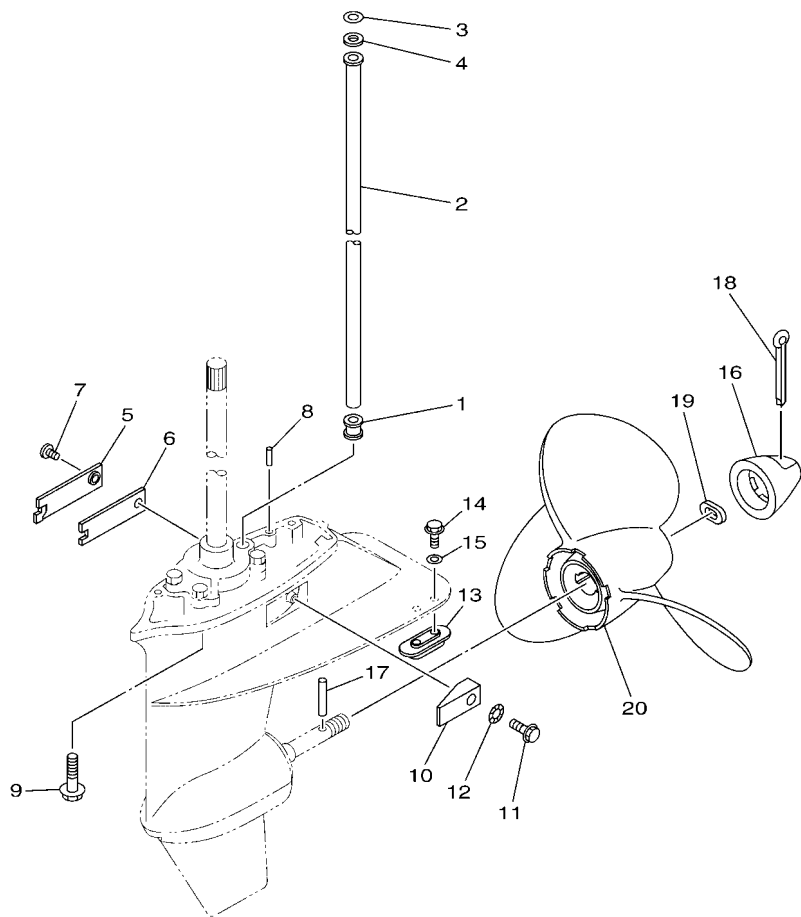

FIG. 18 LOWER CASING & DRIVE 1

REF. NO.	PART NO.	DESCRIPTION	6F5H			REMARKS
47	663-45631-01	CLUTCH, DOG	1			
48	90250-06023	PIN, STRAIGHT	1			
49	663-45633-00	RING, CROSS PIN	1			
50	90201-20MA8	WASHER, PLATE	1			
51	90501-16M01	SPRING, COMPRESSION	1			
52	6F5-45570-00	GEAR 2 (24T)	1			
53	676-45577-00	SHIM (T:1.8MM)	1			UR
	676-45577-10	SHIM (T:1.9MM)	1			UR
	676-45577-20	SHIM (T:2.0MM)	1			UR
	676-45577-30	SHIM (T:2.1MM)	1			UR
	676-45577-40	SHIM (T:2.2MM)	1			UR
	676-45577-50	SHIM (T:2.3MM)	1			UR
	676-45577-60	SHIM (T:2.4MM)	1			UR
	676-45577-70	SHIM (T:2.5MM)	1			UR
54	676-45361-01-CA	CAP, LOWER CASING	1			
55	93306-20401	BEARING	1			
56	93101-20048	OIL SEAL	2			
57	93210-57M00	O-RING	1			
58	676-44150-10	SHIFT CAM ASSY	1			L(22.5")
59	650-45321-00	PLATE	1			
60	97095-06010	BOLT	1			
61	650-44147-00	BOOT, SHIFT ROD	1			





6J4B200-L240

FIG. 19 LOWER CASING & DRIVE 2

REF. NO.	PART NO.	DESCRIPTION	6F5H				REMARKS
1	663-44367-00	DAMPER, WATER SEAL 3	1				
2	676-44361-10	TUBE, WATER 1	1				L(22.5")
3	90202-12060	WASHER, PLATE	1				
4	90430-12072	GASKET	1				
5	6F5-45214-00	COVER, WATER INLET 1	1				
6	6F5-45252-00	SEAT	1				
7	90152-06M06	SCREW, COUNTERSUNK	1				
8	93606-12019	PIN, DOWEL	2				
9	97575-08530	BOLT, WITH WASHER	6				
10	6F5-45251-02	ANODE	1				
11	90105-06M21	BOLT, FLANGE	1				
12	92990-06300	WASHER, INTERNAL TOOTH	1				
13	6E0-45251-12	ANODE	1				
14	95895-06016	BOLT, FLANGE	2				
15	92990-06300	WASHER, INTERNAL TOOTH	2				
16	676-45616-A0	NUT, PROPELLER	1				
17	90250-07M00	PIN, STRAIGHT	1				
18	91490-40040	PIN. COTTER	1				
19	90206-16M03	WASHER, WAVE	1				
20	676-45956-61	PROPELLER (3X11-3/4"X7-1/2"-H)	1				UR
	676-45947-62	PROPELLER (3X11-3/4"X8-3/4"-H)	1				UR
	676-45945-62	PROPELLER (3X11-3/4"X10"-H)	1				UR
	676-45941-62	PROPELLER (3X11-1/2"X11"-H)	1				UR
	676-45943-62	PROPELLER (3X11-1/2"X12"-H)	1				UR
	676-45949-62	PROPELLER (3X11-1/2"X13-1/2"-H)	1				UR
	676-45952-62	PROPELLER (3X11-1/2"X13"-H)	1				UR

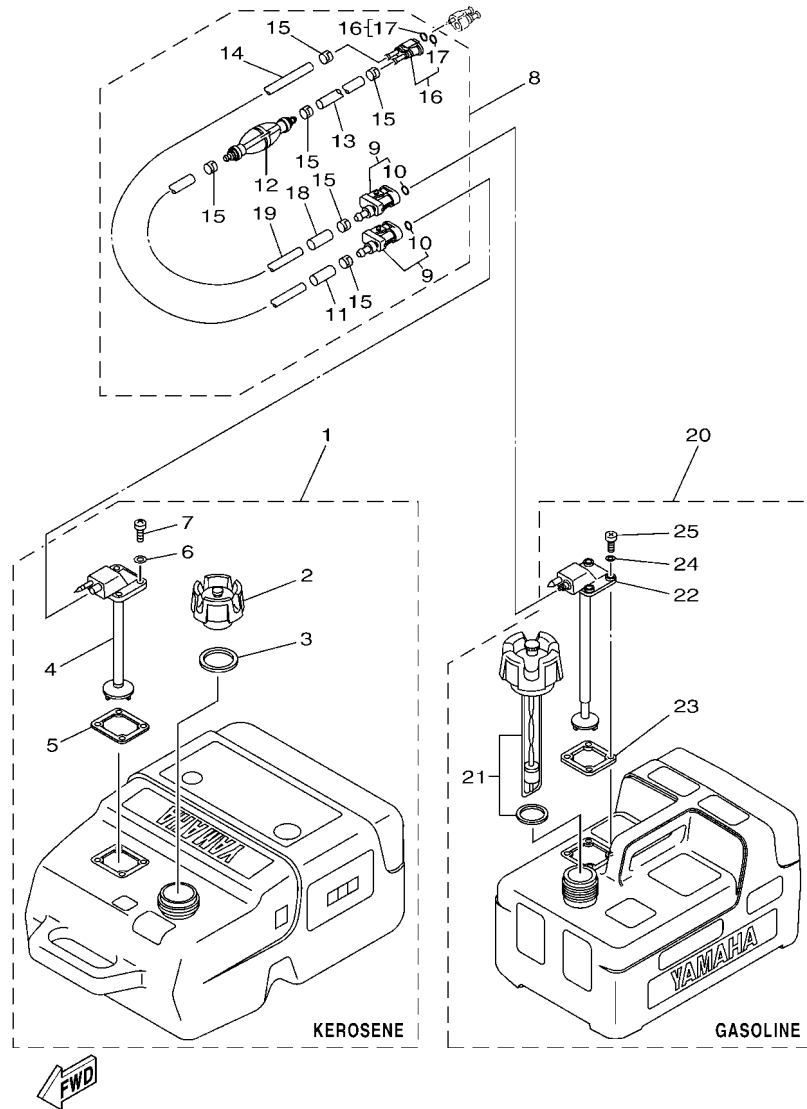
FIG. 20 FUEL TANK



680F200-P180

REF. NO.	PART NO.	DESCRIPTION	QTY	REMARKS
1	6YK-24201-22	FUEL TANK ASSY (25L,KEROSENE)	1	AP KEROSENE
2	6YK-24610-10	.CAP ASSY	1	WITHOUT INDICATOR
3	6YL-24641-00	.GASKET, CAP 1	1	
4	6YK-24260-10	.FUEL METER ASSY	1	
5	6YL-24268-01	.GASKET, FUEL METER	1	
6	6YL-24329-00	.SEAL	4	
7	90157-05M16	.SCREW, PAN HEAD	4	
8	6YK-24306-04	FUEL PIPE COMP. 1	1	AP
9	6Y1-24305-06	.FUEL PIPE JOINT COMP. 2	2	
10	93210-08287	..O-RING	1	
11	6Y1-24397-10	.COLLAR (KEROSENE)	1	
12	61J-24360-00	.PRIMER PUMP ASSY	1	
13	90445-11M05	.HOSE (L850)	1	
14	90445-11M81	.HOSE (L3000)	1	
15	650-24351-51	.BAND 1	6	
16	680-24305-01	.FUEL PIPE JOINT COMP. 2	1	
17	93210-08287	..O-RING	2	
18	6Y1-24397-00	.COLLAR (GASOLINE)	1	
19	90445-11M06	.HOSE (L2050)	1	
20	6YL-24201-06	FUEL TANK ASSY (12L)	1	AP GASOLINE
21	6YL-24610-01	.CAP ASSY	1	
22	6YL-24260-10	.FUEL METER ASSY	1	
23	6YL-24268-01	.GASKET, FUEL METER	1	
24	6YL-24329-00	.SEAL	4	
25	90157-05M16	.SCREW, PAN HEAD	4	

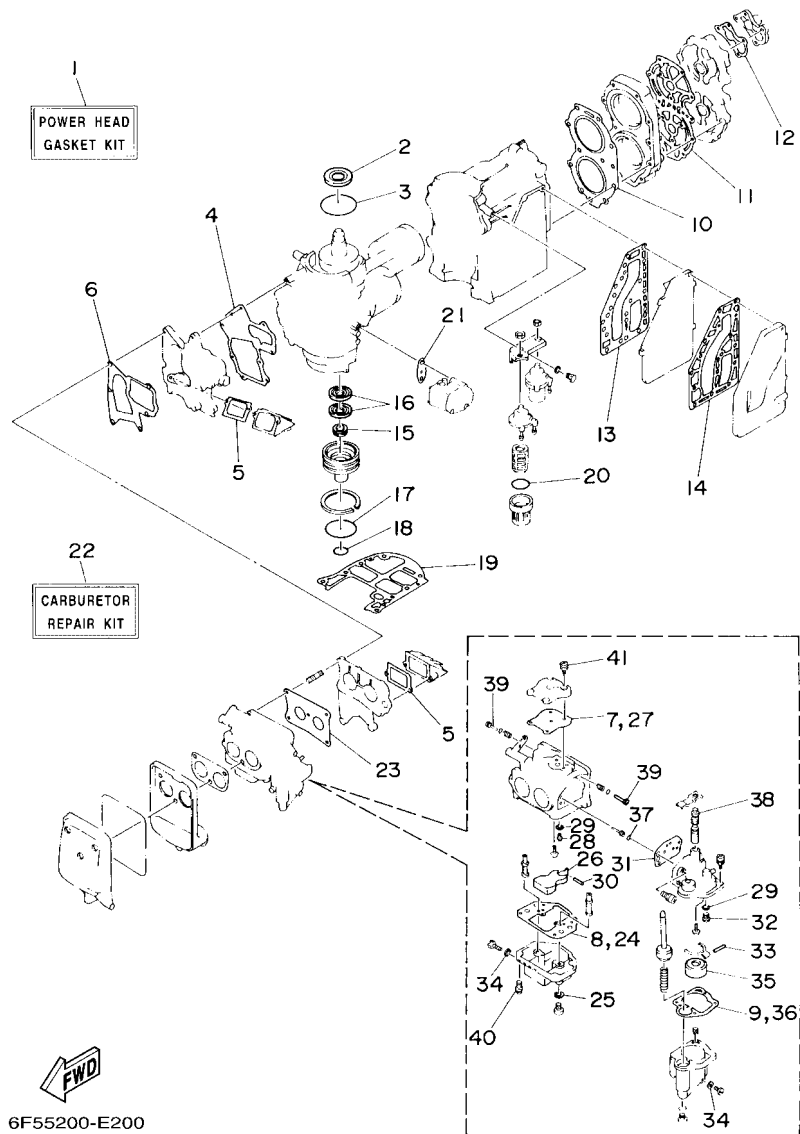
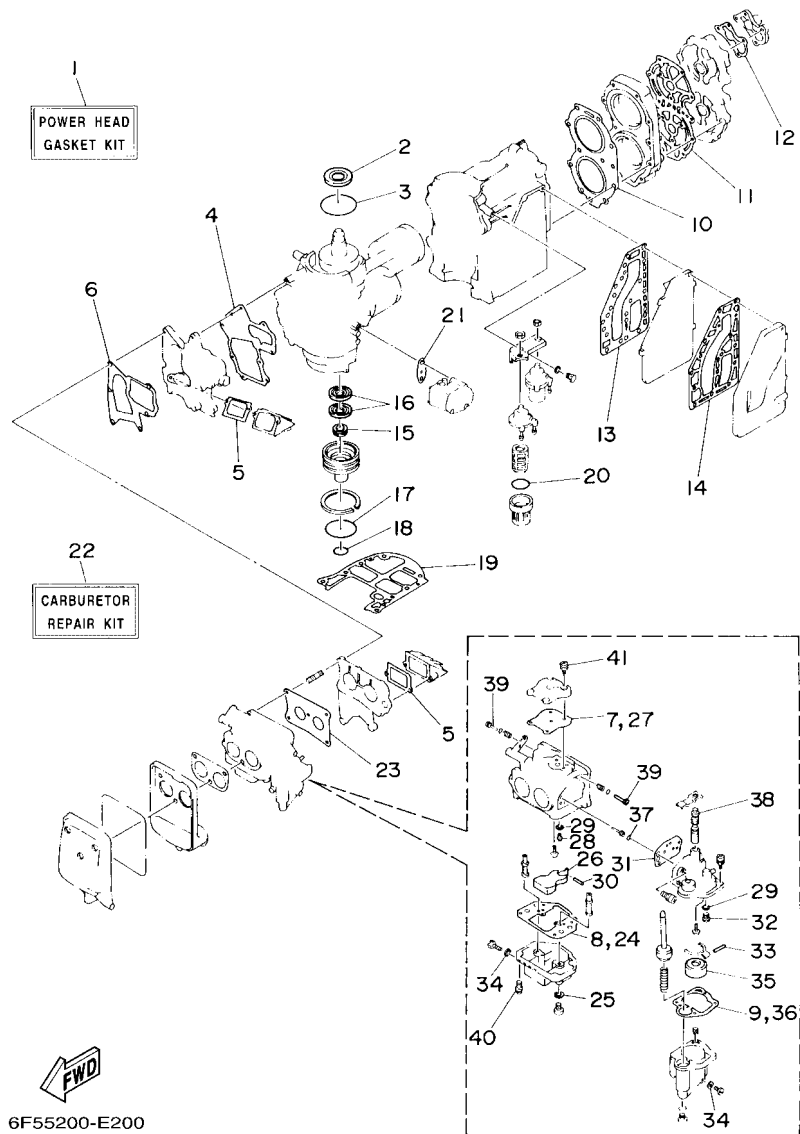

FIG. 21 REPAIR KIT 1

REF. NO.	PART NO.	DESCRIPTION	6F5H	REMARKS
1	6F5-W0001-A2	POWER HEAD GASKET KIT	1	
2	93102-35M18	.OIL SEAL	1	
3	93210-75M51	.O-RING	1	
4	6F5-13646-A2	.GASKET, MANIFOLD 2	1	
5	6F5-13621-A1	.GASKET, VALVE SEAT	2	
6	6F5-13645-A1	.GASKET, MANIFOLD 1	1	
7	6F5-14398-00	.GASKET	1	
8	6F5-14384-00	.GASKET, FLOAT CHAMBER	1	
9	6F5-14384-10	.GASKET, FLOAT CHAMBER	1	
10	6F5-11181-A2	.GASKET, CYLINDER HEAD 1	1	
11	6F5-11193-A1	.GASKET, HEAD COVER 1	1	
12	676-12414-A1	.GASKET, COVER	1	
13	6F5-41112-A0	.GASKET, EXHAUST INNER COVER	1	
14	6F5-41114-A0	.GASKET, EXHAUST OUTER COVER	1	
15	93104-16M01	.OIL SEAL	1	
16	93101-30M33	.OIL SEAL	2	
17	93210-65M50	.O-RING	1	
18	93210-22M02	.O-RING	1	
19	6F5-45113-A1	.GASKET, UPPER CASING	1	
20	93210-32738	.O-RING	2	
21	650-24431-A0	.GASKET, FUEL PUMP 1	1	
22	6F5-W0093-01	CARBURETOR REPAIR KIT	1	
23	6F5-14198-A1	.GASKET	1	
24	6F5-14384-00	.GASKET, FLOAT CHAMBER	1	
25	1J2-14398-00	.GASKET	2	
26	6F6-14385-00	.FLOAT	1	
27	6F5-14398-00	.GASKET	1	



6F55200-E200

FIG. 21 REPAIR KIT 1

REF. NO.	PART NO.	DESCRIPTION	6F5H	REMARKS
28	6F5-14390-21	.NEEDLE VALVE ASSY	1	
29	367-14195-00	.GASKET	2	
30	6E5-14386-01	.PIN, FLOAT	1	
31	6F5-14399-00	.GASKET	1	
32	6F5-14390-12	.NEEDLE VALVE ASSY	1	
33	367-14386-00	.PIN, FLOAT	1	
34	6E5-14398-00	.GASKET	2	
35	626-14385-00	.FLOAT	1	
36	6F5-14384-10	.GASKET, FLOAT CHAMBER	1	
37	6F5-14397-00	.O-RING	2	
38	6F5-14371-00	.PLUNGER, STARTER	1	
39	6F5-14323-01	.SCREW, AIR ADJUSTING	2	
40	97603-05117	.SCREW, PAN HEAD WITH WASHER	4	
41	97603-04114	.SCREW, PAN HEAD WITH WASHER	8	

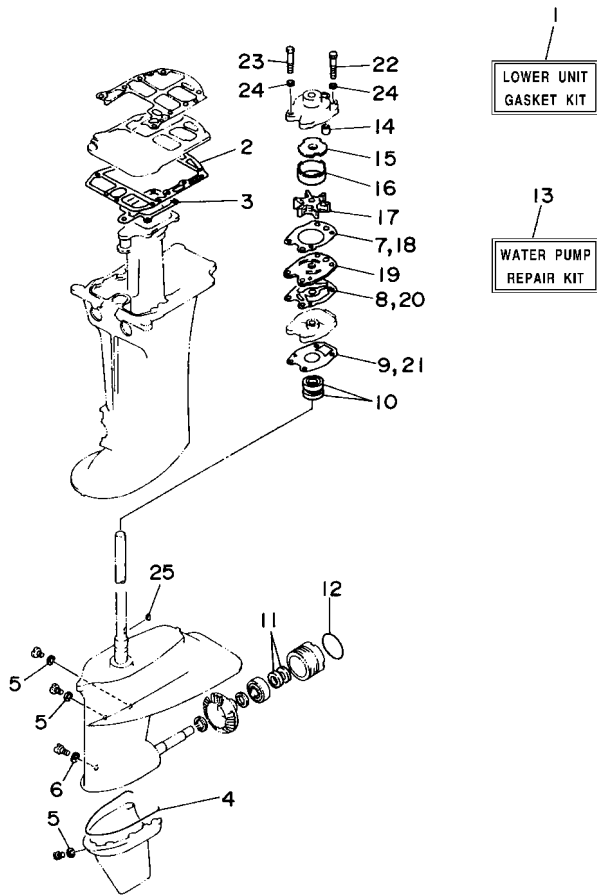

6J46200-F310

FIG. 22 REPAIR KIT 2

REF. NO.	PART NO.	DESCRIPTION	6F5H				REMARKS
1	6F5-W0001-C0	LOWER UNIT GASKET KIT	1				
2	676-45114-A1	.GASKET, UPPER CASING	1				
3	676-41133-A1	.GASKET, EXHAUST MANIFOLD 1	1				
4	676-45314-00	.SEAL, LOWER CASING	1				
5	90430-08003	.GASKET	3				
6	90430-06M03	.GASKET	1				
7	676-44315-A1	.GASKET, WATER PUMP	1				
8	676-44324-A1	.GASKET, CARTRIDGE	1				
9	676-44316-A1	.GASKET, WATER PUMP	1				
10	93101-22M00	.OIL SEAL	2				
11	93101-20048	.OIL SEAL	2				
12	93210-57M00	.O-RING	1				
13	6F6-W0078-00	WATER PUMP REPAIR KIT	1				
14	663-44366-00	.DAMPER, WATER SEAL 2	1				
15	676-44321-40	.INNER PLATE, CARTRIDGE	1				
16	676-44322-40	.INSERT, CARTRIDGE	1				
17	6F5-44352-00	.IMPELLER	1				
18	676-44315-A1	.GASKET, WATER PUMP	1				
19	676-44323-40	.OUTER PLATE, CARTRIDGE	1				
20	676-44324-A1	.GASKET, CARTRIDGE	1				
21	676-44316-A1	.GASKET, WATER PUMP	1				
22	97095-08055	.BOLT	2				
23	97095-08045	.BOLT	2				
24	92995-08600	.WASHER	4				
25	90280-04M00	.KEY, WOODRUFF	1				

NUMERICAL INDEX

PART NO.	REF. NO.	PART NO.	REF. NO.	PART NO.	REF. NO.	PART NO.	REF. NO.	PART NO.	REF. NO.	PART NO.	REF. NO.
6F5-11111-00-1S	3 - 23	6F5-14182-41	6 - 17	6E5-14386-01	21 - 30	6A0-15758-01-8D	9 - 27	677-24434-02	7 - 26	650-42152-00-94	13 - 13
6F5-11119-00	3 - 21	367-14195-00	6 - 13	6F5-14387-00	6 - 20	6A0-15761-00	2 - 3	648-24435-02	7 - 36	676-42159-00	13 - 11
6F5-11181-A2	3 - 24		21 - 29	6F5-14387-00	6 - 18	6A0-15762-01	9 - 29	677-24435-02	7 - 23	6G1-42177-00	13 - 4
	21 - 10	6F5-14198-A1	5 - 20		21 - 32	6F5-15764-00	9 - 15	677-24444-01	7 - 20	676-42511-03-8D	15 - 24
6F5-11191-00-1S	3 - 26		21 - 23	6F5-14390-21	6 - 12	6F5-15768-00	9 - 19	677-24471-01	7 - 22	676-42521-00	15 - 28
6F5-11193-A1	3 - 27	654-14243-00	6 - 47		21 - 28	6F5-15770-00	9 - 37	61N-24521-00	7 - 10	648-42528-00	15 - 14
	21 - 11	6F5-14301-42	6 - 1	6A4-14394-00	6 - 33	6F5-15771-00-94	9 - 31	61N-24560-00	7 - 8	676-42591-00	15 - 67
676-11325-00	1 - 2	650-14321-01	6 - 44	5Y1-14397-00	6 - 53	6F5-15772-00-94	9 - 33	61N-24563-00	1 - 7	6F5-42610-10	2 - 1
	3 - 17	6F5-14323-01	6 - 40	652-14397-00	6 - 34	6F5-15773-00	9 - 39		7 - 9	6F5-42613-A0-8D	2 - 8
6F5-11325-00	1 - 3		21 - 39	6F5-14397-00	6 - 26	6F5-15774-00	9 - 38	6F5-24566-00	7 - 12	6F5-42615-00	2 - 10
	3 - 19	6A0-14325-00	7 - 32		21 - 37	6F5-15779-02	9 - 21	6YL-24610-01	20 - 21	6F5-4261A-00	2 - 2
650-11370-01	3 - 4	6E7-14325-00	7 - 33	1J2-14398-00	6 - 5	6A0-15789-00	9 - 30	6YK-24610-10	20 - 2	6E9-42651-01	2 - 4
	5 - 5	6F5-14332-01	6 - 29		21 - 25	6F5-15791-00	9 - 18	6YL-24641-00	20 - 3	6F5-42652-01	2 - 6
6F6-11370-01	5 - 4	647-14334-00	6 - 45	6E5-14398-00	6 - 23	6YL-24201-06	20 - 20	6F5-26311-00	13 - 19	61N-42675-40	2 - 11
6F5-11400-11	4 - 1	6F5-14334-01	6 - 41		21 - 34	6YK-24201-22	20 - 1	676-26326-00	12 - 13	61N-42676-40	2 - 12
6F5-11412-11	4 - 2	6F5-14339-00	6 - 32	6F5-14398-00	6 - 8	6YK-24260-10	20 - 4	676-26391-00	13 - 20	63D-42678-40	2 - 13
6F5-11422-11	4 - 3	6F5-14340-00	6 - 50		21 - 7	6YL-24260-10	20 - 22	676-26392-00	13 - 21		2 - 14
6F5-11432-11	4 - 4	6F5-14341-00	6 - 4		21 - 27	6YL-24268-01	20 - 5	6F5-41111-01-1S	3 - 36	61R-42681-00	2 - 15
6F5-11442-11	4 - 5	647-14342-30	6 - 11	6F5-14399-00	6 - 16		20 - 23	6F5-41112-A0	3 - 35		2 - 16
6F5-11515-00	4 - 9	647-14342-45	6 - 10		21 - 31	680-24304-10	7 - 1		21 - 13	680-42684-00	2 - 17
6F5-11610-00	4 - 16	677-14343-73	6 - 6	6F5-14417-00	5 - 23	680-24305-01	8 - 6	6F5-41113-A0-1S	3 - 34	6F5-42711-03-8D	12 - 1
6F5-11610-10	4 - 16	647-14344-35	6 - 36	6F5-14418-00	5 - 24		20 - 16	6F5-41114-A0	3 - 37	6F5-42715-00	14 - 19
6F5-11610-20	4 - 16	6F5-14346-00	6 - 46	6F5-14425-00	6 - 51	6Y1-24305-06	20 - 9		21 - 14	6F5-42716-00	12 - 10
6F6-11631-00-95	4 - 15	6A4-14355-00	6 - 28	6F5-14476-00	5 - 27	6Y3-24306-04	8 - 1	6F5-41116-00-CA	17 - 5	6F5-42724-00	12 - 11
6F5-11633-00	4 - 17	6F5-14369-00	6 - 30	6F5-14483-00	5 - 31	6YK-24306-04	20 - 8	676-41131-01-CA	17 - 11	676-42726-00	12 - 24
663-11634-00	4 - 18	6F5-14370-02	6 - 31	624-14485-00	3 - 3	6A4-24329-00	7 - 3	676-41133-A1	17 - 12	6F5-42727-00	12 - 12
6F6-11635-00	4 - 15	6F5-14371-00	6 - 35		5 - 18	6YL-24329-00	20 - 6		22 - 3	6F5-42738-01-94	12 - 8
6F6-11636-00	4 - 15		21 - 38		5 - 28		20 - 24	6F5-41137-03-CA	17 - 7	6F5-42741-11	12 - 18
6F5-11651-00	4 - 11	6F5-14372-01	6 - 27	6F5-14497-00	14 - 1	650-24351-51	8 - 5	6F5-41141-00	17 - 8	6EE-42794-40	12 - 26
6F5-11681-00	4 - 12	6F5-14377-00	6 - 37	6F6-15100-02	3 - 2		20 - 15	6F5-41211-00	14 - 7	6F5-42815-01-8D	12 - 3
6F5-12411-03	1 - 4	6F5-14379-00	6 - 43	6F5-15396-01-CA	3 - 8	61J-24360-00	8 - 3	6E9-41237-00	14 - 8	6F5-42816-00	12 - 5
	3 - 29	6F5-14381-00	6 - 3	6F5-15711-02	9 - 2		20 - 12	6F5-41252-00	5 - 32	676-43111-04-8D	15 - 1
6E5-12412-00	3 - 30	6F5-14381-11	6 - 21	6F5-15713-00	9 - 5	6Y1-24397-00	20 - 18	6F5-41256-00	5 - 35	676-43112-04-8D	15 - 7
676-12413-00-1S	3 - 31	6F5-14383-00	6 - 9	6F5-15714-03	9 - 3	6Y1-24397-10	20 - 11	6F5-41262-01	6 - 42	6J8-43113-01	15 - 21
676-12414-A1	1 - 5	6F5-14383-10	6 - 22	6F5-15715-00	9 - 6	6F5-24410-06	7 - 19	661-41262-02	5 - 36	6F5-43114-00	15 - 2
	3 - 32	6F5-14384-00	6 - 2	6F5-15716-01	9 - 8	648-24411-00	7 - 28		9 - 45	6F5-43116-00	15 - 3
	21 - 12		21 - 8	6F5-15723-01	9 - 22	663-24411-00	7 - 35	682-41271-01	5 - 33	663-43118-01-8D	15 - 4
6F5-13610-00	5 - 1		21 - 24	6F5-15726-01	9 - 11	677-24411-02	7 - 25	689-41273-00	5 - 34	6J8-43131-01	15 - 18
6F5-13621-A1	5 - 8	6F5-14384-10	6 - 25	6F5-15734-01	9 - 7	682-24412-01	7 - 24	6F5-41283-00	14 - 3	676-43132-00	16 - 2
	5 - 16		21 - 9	6F5-15739-00	9 - 20	6A0-24412-02	7 - 40	6F5-41638-00	14 - 2	6G5-43145-01	15 - 23
	21 - 5		21 - 36	6F5-15741-01	9 - 4	6A0-24413-00	7 - 37	6F5-41662-00	14 - 12	676-43160-02	16 - 26
6F6-13641-00-1S	5 - 3	626-14385-00	6 - 24	6F5-15746-00	9 - 36	677-24413-01	7 - 21	676-42111-03-8D	13 - 2	676-43165-00	16 - 27
6F6-13643-01-1S	5 - 14		21 - 35	6F5-15747-00	9 - 35	6A0-24421-01	7 - 31	676-42115-00	13 - 10	676-43191-00	16 - 8
6F5-13645-A1	5 - 17	6F6-14385-00	6 - 7	656-15748-00	9 - 40	648-24423-00	7 - 30	664-42119-00	13 - 3	676-43311-11-8D	15 - 12
	21 - 6		21 - 26	6F5-15752-00	9 - 16	648-24424-00	7 - 29	6F5-42125-00	13 - 31	663-43318-00	16 - 17
6F5-13646-A2	5 - 6	367-14386-00	6 - 19	6F5-15753-00	9 - 17	650-24431-A0	7 - 41	6F5-42126-00	13 - 30	676-43373-00	15 - 16
	21 - 4		21 - 33	6F5-15754-00	9 - 9		21 - 21	6F5-42137-20	13 - 5	676-43613-00	16 - 20
6F5-13940-01	6 - 54	6E5-14386-01	6 - 15	689-15755-01	9 - 14	648-24434-01	7 - 27	676-42151-00-94	13 - 15	676-43614-00	16 - 18

NUMERICAL INDEX

PART NO.	REF. NO.	PART NO.	REF. NO.	PART NO.	REF. NO.	PART NO.	REF. NO.	PART NO.	REF. NO.	PART NO.	REF. NO.
676-43615-00	16 - 19	676-44551-01-8D	15 - 34	676-45577-60	18 - 53	6F6-W0078-00	1 - 13	90201-09M00	15 - 49	90387-06M41	12 - 15
676-43616-00	16 - 16	676-44552-01-8D	15 - 35	676-45577-70	18 - 53		22 - 13	90201-10M02	13 - 7	90387-07M04	16 - 25
6F5-43627-80	16 - 5	676-44553-01-8D	15 - 36	676-45577-70	18 - 39	6F5-W0084-02-8D	13 - 1	90201-12426	15 - 65	90387-08M02	15 - 9
6F5-43628-80	16 - 6	62Y-44555-00	15 - 37	676-45587-10	18 - 39	6F5-W0090-64-1S	3 - 1	90201-12537	13 - 27	90387-08M05	9 - 26
6F5-43630-80	16 - 12	676-44575-00	15 - 45	676-45587-20	18 - 39	6F5-W0093-01	21 - 22	90201-12M16	15 - 41	90430-06M03	1 - 10
676-43631-00	16 - 13	676-45111-15-8D	17 - 1	676-45587-30	18 - 39	6F5-W1571-03	9 - 1	90201-13M11	15 - 43		18 - 13
676-43643-00	16 - 30	6F5-45113-A1	17 - 2	6F5-45611-01	18 - 44	676-W2810-01	7 - 48	90201-20417	4 - 20		22 - 6
6F5-44111-01	14 - 9		21 - 19	676-45616-A0	19 - 16	90101-08001	3 - 22	90201-20MA8	18 - 50	90430-08003	1 - 9
6F5-44121-00	14 - 14	676-45114-A1	17 - 9	663-45631-01	18 - 47	90101-08M02	15 - 47	90201-21M18	10 - 19		18 - 11
6F5-44125-00	14 - 10		22 - 2	663-45633-00	18 - 49	90101-10M58	15 - 63	90201-22M03	15 - 20		18 - 18
676-44143-00	14 - 23	676-45127-00	17 - 13	663-45634-00	18 - 46	90101-12M01	15 - 40	90201-44M01	15 - 30		22 - 5
648-44146-00	14 - 24	676-45151-10-8D	17 - 15	676-45635-00	18 - 45	90101-12M37	13 - 24	90202-06M00	16 - 10	90430-12072	19 - 4
650-44147-00	18 - 61	6F5-45214-00	19 - 5	676-45941-62	19 - 20	90105-06M01	17 - 6	90202-12060	19 - 3	90445-07240	5 - 29
676-44150-10	18 - 58	676-45215-01	18 - 15	676-45943-62	19 - 20		18 - 22	90202-12092	13 - 26		5 - 39
6F5-44167-00	14 - 20	676-45251-00	1 - 1	676-45945-62	19 - 20	90105-06M21	19 - 11	90202-12M01	16 - 3	90445-07254	5 - 38
6F5-44173-00	14 - 18		3 - 15	676-45947-62	19 - 20	90105-08117	15 - 8	90202-21100	15 - 42	90445-07M24	5 - 40
6X3-44191-00	2 - 18	6F5-45251-02	1 - 11	676-45949-62	19 - 20	90105-08M10	9 - 23	90202-27M23	4 - 13	90445-09226	7 - 4
676-44311-00	18 - 23		19 - 10	676-45952-62	19 - 20	90105-08M35	11 - 22	90206-12052	12 - 7	90445-09M37	3 - 39
676-44315-A1	18 - 26	6E0-45251-12	1 - 12	676-45956-61	19 - 20	90109-06M12	15 - 6	90206-12054	13 - 28	90445-09M53	7 - 43
	22 - 7		19 - 13	6F5-81328-00	10 - 9	90109-06M86	11 - 6	90206-12M00	16 - 4	90445-09M54	7 - 15
	22 - 18	6F5-45252-00	19 - 6	6F5-81948-A0	11 - 21	90116-06M17	5 - 9	90206-16M03	19 - 19	90445-09M55	6 - 52
676-44316-A1	18 - 29	6F5-45279-01	18 - 16	6EE-81994-40	9 - 46	90119-06M11	12 - 20	90209-52M00	15 - 29	90445-10M43	7 - 5
	22 - 9	6F5-45300-12-8D	18 - 1	6EE-81995-40	9 - 47	90119-06M61	12 - 16	90240-05M09	14 - 15	90445-10M50	7 - 16
	22 - 21	6F5-45311-02-8D	18 - 2	703-82119-00	10 - 20	90119-06M65	11 - 4	90243-04007	15 - 5		7 - 44
676-44321-40	18 - 25	6F5-45312-01-8D	18 - 3	61N-82317-00	11 - 2	90119-06M73	12 - 6	90249-07M01	16 - 21	90445-11M05	8 - 4
	22 - 15	676-45314-00	18 - 20	62E-8231X-00	11 - 9	90119-06MA2	3 - 33	90249-07M02	16 - 22		20 - 13
676-44322-40	18 - 24		22 - 4	62E-82371-11	11 - 8	90119-06MA3	3 - 28	90249-12M13	16 - 7	90445-11M06	8 - 2
	22 - 16	650-45321-00	18 - 59	682-82556-00	12 - 22		3 - 38	90249-12M27	16 - 1		20 - 19
676-44323-40	18 - 30	688-45341-10	18 - 19	688-82560-10	11 - 14	90119-08M10	9 - 24	90250-06023	18 - 48	90445-11M81	8 - 8
	22 - 19	676-45361-01-CA	18 - 54	6E9-82575-02	12 - 21	90119-08MA5	3 - 25	90250-07M00	19 - 17		20 - 14
676-44324-A1	18 - 31	676-45501-10	18 - 37	689-8257Y-00	12 - 23	90119-10005	3 - 6	90260-04002	16 - 31	90447-13011	12 - 25
	22 - 8	676-45533-00	18 - 5	6F5-82580-00	11 - 15	90119-10028	3 - 7	90266-04M01	2 - 7	90462-08096	11 - 16
	22 - 20	676-45536-00	18 - 7	6F5-82588-00	11 - 20	90149-06M00	18 - 14	90266-04M04	2 - 5	90464-07008	7 - 47
676-44341-01	18 - 32	6F5-45551-01	18 - 38	6F5-85515-10	10 - 8	90152-05011	13 - 6	90280-04M00	18 - 28	90465-08M07	11 - 12
6F5-44352-00	18 - 27	6F5-45560-01	18 - 41	6F5-85520-10	10 - 4	90152-06M01	3 - 18		22 - 25	90465-11M10	11 - 10
	22 - 17	676-45567-00	18 - 42	6F6-85530-01	11 - 7	90152-06M06	19 - 7	90280-05015	10 - 17	90465-11M52	15 - 62
676-44361-10	19 - 2	676-45567-10	18 - 42	6F5-85533-10	10 - 5	90157-05M16	20 - 7	90340-08002	18 - 12	90465-13M18	11 - 17
663-44366-00	18 - 36	676-45567-20	18 - 42	6F5-85540-32	11 - 5		20 - 25	90385-12M04	9 - 25	90467-06016	5 - 13
	22 - 14	676-45567-30	18 - 42	6F5-85542-10	11 - 1	90159-04035	10 - 12	90386-08032	13 - 9		5 - 19
663-44367-00	19 - 1	676-45567-40	18 - 42	6F5-85550-G0	10 - 1	90159-04063	10 - 11	90386-08M00	13 - 18		5 - 30
6E5-44391-00	12 - 2	676-45567-50	18 - 42	6F5-85560-B0	10 - 2	90159-05040	10 - 10	90386-12089	13 - 23		5 - 41
676-44511-00	15 - 55	6F5-45570-00	18 - 52	6F5-85580-10	10 - 6	90159-06M01	5 - 25	90386-12M37	12 - 4	90467-08004	3 - 40
676-44512-00	15 - 56	676-45577-00	18 - 53	6F5-85580-20	10 - 7	90170-07021	14 - 25	90386-22M15	15 - 19		7 - 6
679-44514-00	15 - 46	676-45577-10	18 - 53	6F5-85597-H0	10 - 14	90170-20137	10 - 18	90386-44M03	15 - 32		7 - 17
676-44518-00	15 - 52	676-45577-20	18 - 53	6F5-85597-J0	10 - 13	90185-08057	15 - 50	90386-52M02	15 - 31		7 - 45
676-44521-00	15 - 60	676-45577-30	18 - 53	6F5-W0001-A2	21 - 1	90185-12058	13 - 29	90387-06119	11 - 3	90467-09M03	7 - 7
676-44522-01	15 - 61	676-45577-40	18 - 53	6F5-W0001-C0	22 - 1	90185-22043	15 - 22	90387-06M29	9 - 44		7 - 18
676-44533-00	15 - 51	676-45577-50	18 - 53	6F5-W0004-00	5 - 2	90201-08M08	15 - 48		14 - 4		7 - 46

NUMERICAL INDEX

PART NO.	REF. NO.	PART NO.	REF. NO.	PART NO.	REF. NO.	PART NO.	REF. NO.	PART NO.	REF. NO.	PART NO.	REF. NO.
90480-09M21	12 - 14	93210-32738	1 - 8	97095-05010	16 - 14	97980-05114	5 - 7				
90480-25161	11 - 11		7 - 11	97095-06010	18 - 60		5 - 15				
90501-07M33	14 - 22		21 - 20	97095-06010	15 - 53	98503-05028	7 - 38				
90501-10227	9 - 41	93210-57M00	18 - 57	97095-08045	22 - 23	98980-04006	6 - 14				
90501-12M36	14 - 21		22 - 12	97095-08050	15 - 57	99080-10600	16 - 9				
90501-14M05	16 - 11	93210-65M50	3 - 11	97095-08055	22 - 22						
90501-16M01	18 - 51		21 - 17	97513-06525	5 - 12						
90501-18M00	15 - 15	93210-75M51	10 - 15		12 - 9						
90501-23215	13 - 8		21 - 3		14 - 13						
90502-10M04	16 - 29	93306-20401	18 - 55	97513-08535	9 - 32						
90506-30M00	16 - 23	93306-306U2	4 - 8		9 - 34						
90508-14M00	16 - 15	93306-307U0	4 - 6	97575-08525	15 - 17						
91490-16010	13 - 33	93310-727V7	4 - 14	97575-08530	15 - 25						
	14 - 16	93315-217U0	18 - 4		15 - 38						
91490-20012	16 - 24	93315-324U1	18 - 8		19 - 9						
91490-40040	19 - 18	93332-000U0	18 - 43	97575-08535	15 - 26						
91690-25016	14 - 11	93332-000UE	4 - 7	97595-05510	13 - 22						
91690-30010	3 - 14	93342-624U0	18 - 9	97595-06516	3 - 16						
	16 - 28	93390-000U0	18 - 10		9 - 28						
91690-30025	13 - 14	93410-16007	18 - 40		9 - 42						
91690-40032	5 - 37	93440-68M03	3 - 13		11 - 18						
92903-06600	5 - 11		4 - 10		11 - 19						
92990-05100	7 - 39	93603-21111	4 - 19		14 - 6						
92990-06100	13 - 17	93604-08062	18 - 33	97595-06520	13 - 12						
92990-06300	19 - 12	93604-09068	18 - 21		17 - 14						
	19 - 15	93606-12019	19 - 8	97595-06525	7 - 2						
92990-08100	15 - 10	93606-25M00	17 - 3		11 - 13						
92990-12200	13 - 25	93608-12063	3 - 5		12 - 19						
92995-06600	5 - 21		15 - 27		17 - 10						
92995-08600	15 - 58	93700-06M03	15 - 13	97595-06530	9 - 43						
	22 - 24	94702-00040	1 - 6		14 - 5						
92995-10600	15 - 64		3 - 41	97595-06540	10 - 16						
93101-20048	18 - 56	95303-08700	9 - 12	97595-06555	7 - 42						
	22 - 11	95380-03600	7 - 34	97595-06616	2 - 9						
93101-22M00	18 - 6	95380-06600	5 - 22	97595-08540	17 - 4						
	22 - 10		12 - 17	97595-08545	15 - 39						
93101-30M33	3 - 9		13 - 16		18 - 35						
	21 - 16		13 - 32	97595-08555	18 - 34						
93102-35M18	10 - 3		15 - 54	97603-04114	6 - 38						
	21 - 2	95380-08600	7 - 13		21 - 41						
93104-16M01	3 - 10		15 - 11	97603-05117	6 - 49						
	21 - 15		15 - 59		21 - 40						
93109-44M00	15 - 33	95380-10600	15 - 66	97603-06113	6 - 48						
93210-08287	8 - 7	95380-12800	15 - 44	97603-06120	6 - 39						
	20 - 10	95895-06016	19 - 14	97780-40520	14 - 17						
	20 - 17	97013-06014	7 - 14	97780-50716	5 - 26						
93210-22M02	3 - 12	97013-06065	5 - 10	97780-60525	18 - 17						
	21 - 18	97013-08030	9 - 10	97880-05030	3 - 20						